

VILLAGE OF DOWNERS GROVE
Report for the Village Council Meeting
6/6/2023

SUBJECT:	SUBMITTED BY:
Award of Contract - 2023 Pavement Striping Maintenance (TR-023)	Scott Vasko Assistant Public Works Director - Engineering

SYNOPSIS

A motion is requested to award a contract for pavement marking striping maintenance to Superior Road Striping, Inc., in the amount of \$150,000.00.

STRATEGIC PLAN ALIGNMENT

The strategic goals for 2021-2023 include *Top Quality Infrastructure*.

FISCAL IMPACT

The FY23 budget includes \$150,000 for this project in the Capital Projects Fund for Pavement Striping Maintenance (TR-023).

RECOMMENDATION

Approval on the June 6, 2023 consent agenda.

BACKGROUND

The Village has over 26 miles of thermoplastic pavement markings comprised of stop bars, centerlines, lane lines and turn arrows. Over time they wear and require replacement due to normal weathering, traffic, snow plowing and construction activities. Staff's observations indicate that the average life of thermoplastic pavement markings in the Village is approximately four years.

This project is recommended to be completed through a cooperative purchasing contract with DuPage County's 2023 Pavement Marking Maintenance Contract, which included a Joint Purchase line item and allows for pricing to be extended to local governments in accordance with the provisions of the Village Purchasing Policy.

Staff recommends award of this contract to Superior Road Striping, Inc.

ATTACHMENTS

Contract Documents
Contractor Evaluation



Local Public Agency Formal Contract



Contractor's Name

Superior Road Striping, Inc.

Contractor's Address

1980 N. Hawthorne Ave.

City

Melrose Park

State

IL

Zip Code

60160

STATE OF ILLINOIS

Local Public Agency

County of DuPage

County

DuPage

Section Number

23-PVMG-11-GM

Street Name/Road Name

2022 Pavement Marking Maintenance

Type of Funds

Motor Fuel Tax

CONTRACT BOND (when required)

For a County and Road District Project

Submitted/Approved

Highway/Commissioner Signature

Date

[Signature]

[Date]

Submitted/Approved

County Engineer/Superintendent of Highways

Date

Christopher Myer

5/10/23

For a Municipal Project

Submitted/Approved/Passed

Signature

Date

[Signature]

[Date]

Official Title

[Title]

Department of Transportation

Concurrence in approval of award

Regional Engineer Signature

Date

[Signature]

[Date]



Contract Bond

Bond No. 800114614

Local Public Agency	County	Street Name/Road Name	Section Number
County of DuPage	DuPage	Various	23-PVMKG-11-GM

Bond information to be returned to Local Public Agency at Div of Trans, 421 N County Farm Rd., Wheaton, IL 60187
Complete Address

We, Superior Road Striping, Inc. 1980 Hawthorne Avenue, Melrose Park, IL 60160
Contractor's Name and Address

a/an Corporation organized under the laws of the State of IL as PRINCIPAL, and
State

Atlantic Specialty Insurance Company 605 Highway 169 North, Suite 800, Plymouth, MN 55441
Surety Name and Address

as SURETY, are held and firmly bound unto the above Local Public Agency (hereafter referred to as "LPA") in the penal sum of
Four Hundred Ninety Five Thousand Six Hundred Twenty Four Dollars and 95/100

Dollars (\$495,624.95) lawful money of the United States, to be paid to said LPA, the payment of which we bind ourselves, successors and assigns jointly to pay to the LPA this sum under the conditions of this instrument.

WHEREAS, THE CONDITION OF THE FOREGOING OBLIGATION IS SUCH that the said Principal has entered into a written contract with the LPA acting through its awarding authority for the construction of work on the above sections, which contract is hereby referred to and made a part hereof, as if written herein at length, and whereby the said Principal has promised and agreed to perform said work in accordance with the terms of said contract, and has promised to pay all sums of money due for any labor, materials, apparatus, fixtures or machinery furnished to such Principal for the purpose of performing such work and has further agreed to pay all direct and indirect damages to any person, firm, company or corporation to whom any money may be due from the Principal, subcontractor or otherwise for any such labor, materials, apparatus, fixtures or machinery so furnished and that suit may be maintained on such bond by any such person, firm, company or corporation for the recovery of any such money.

NOW, THEREFORE, if the said Principal shall perform said work in accordance with the terms of said contract, and shall pay all sums of money due or to become due for any labor, materials, apparatus, fixtures or machinery furnished to it for the purpose of constructing such work, and shall commence and complete the work within the time prescribed in said contract, and shall pay and discharge all damages, direct and indirect, that may be suffered or sustained on account of such work during the time of the performance thereof and until the said work shall have been accepted, and shall hold the LPA and its awarding authority harmless on account of any such damages and shall in all respects fully and faithfully comply with all the provisions, conditions and requirements of said contract, then this obligation shall be void; otherwise it shall remain in full force and effect.

IN TESTIMONY WHEREOF, the said PRINCIPAL and the said SURETY have caused this instrument to be signed by their respective agents this 21st day of April, 2023
Day Month and Year

PRINCIPAL

Company Name
Superior Road Striping, Inc.

Company Name

By
Signature & Date
Joan Yario President

By
Signature & Date

Attest
Signature & Date
Joseph Yario VP, Treasurer

Attest
Signature & Date

(If PRINCIPAL is a joint venture of two or more contractors, the company names and authorized signature of each contractor must be affixed.)

STATE OF Illinois

COUNTY OF DuPage

I, Sandra DeHoyos, a Notary Public in and for said county, do hereby certify that

Notary Name

Joan Yario and Joseph Yario

Insert name of Individuals signing on behalf of PRINCIPAL

who is/are each personally known to me to be the same person(s) whose name(s) is/are subscribed to the foregoing instrument on behalf of PRINCIPAL, appeared before me this day in person and acknowledged respectively, that he/she/they signed and delivered said instrument freely and voluntarily for the uses and purposes therein set forth.

Given under my hand and notarial seal this 21 day of April 2023.

(SEAL)

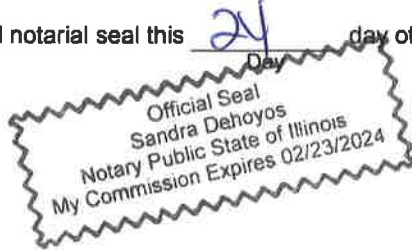

Notary Public Signature & Date

[Signature]

Date commission expires February 23, 2024

Sandra DeHoyos

SURETY

Name of Surety

Atlantic Specialty Insurance Company

Title

Jodie Sellers

Jodie Sellers, Attorney-in-Fact



STATE OF Illinois

COUNTY OF Cook

I, Donna Irigoyen, a Notary Public in and for said county, do hereby certify that

Notary Name

Jodie Sellers, Attorney-in-Fact

Insert name of Individuals signing on behalf of SURETY

who is/are each personally known to me to be the same person(s) whose name(s) is/are subscribed to the foregoing instrument on behalf of SURETY, appeared before me this day in person and acknowledged respectively, that he/she/they signed and delivered said instrument freely and voluntarily for the uses and purposes therein set forth.

Given under my hand and notarial seal this 21st day of April, 2023.

(SEAL)



Notary Public Signature & Date

[Signature] 4/21/23

Date commission expires July 13, 2025

Donna Irigoyen

Approved this Day day of Month, Year

Attest:

Local Public Agency Clerk Signature & Date

[Signature]

County

Local Public Agency Type

Clerk

Awarding Authority

County of DuPage

Awarding Authority Signature & Date

[Signature]

5-9-2023



Power of Attorney

Surety Bond No: 800114614

Principal: Superior Road Striping, Inc.
Obligee: County of DuPage

KNOW ALL MEN BY THESE PRESENTS, that ATLANTIC SPECIALTY INSURANCE COMPANY, a New York corporation with its principal office in Plymouth, Minnesota, does hereby constitute and appoint: Jodie Sellers, each individually if there be more than one named, its true and lawful Attorney-in-Fact, to make, execute, seal and deliver, for and on its behalf as surety, any and all bonds, recognizances, contracts of indemnity, and all other writings obligatory in the nature thereof; provided that no bond or undertaking executed under this authority shall exceed in amount the sum of: sixty million dollars (\$60,000,000) and the execution of such bonds, recognizances, contracts of indemnity, and all other writings obligatory in the nature thereof in pursuance of these presents, shall be as binding upon said Company as if they had been fully signed by an authorized officer of the Company and sealed with the Company seal. This Power of Attorney is made and executed by authority of the following resolutions adopted by the Board of Directors of ATLANTIC SPECIALTY INSURANCE COMPANY on the twenty-fifth day of September, 2012:

Resolved: That the President, any Senior Vice President or Vice-President (each an "Authorized Officer") may execute for and in behalf of the Company any and all bonds, recognizances, contracts of indemnity, and all other writings obligatory in the nature thereof, and affix the seal of the Company thereto; and that the Authorized Officer may appoint and authorize an Attorney-in-Fact to execute on behalf of the Company any and all such instruments and to affix the Company seal thereto; and that the Authorized Officer may at any time remove any such Attorney-in-Fact and revoke all power and authority given to any such Attorney-in-Fact.

Resolved: That the Attorney-in-Fact may be given full power and authority to execute for and in the name and on behalf of the Company any and all bonds, recognizances, contracts of indemnity, and all other writings obligatory in the nature thereof, and any such instrument executed by any such Attorney-in-Fact shall be as binding upon the Company as if signed and sealed by an Authorized Officer and, further, the Attorney-in-Fact is hereby authorized to verify any affidavit required to be attached to bonds, recognizances, contracts of indemnity, and all other writings obligatory in the nature thereof.

This power of attorney is signed and sealed by facsimile under the authority of the following Resolution adopted by the Board of Directors of ATLANTIC SPECIALTY INSURANCE COMPANY on the twenty-fifth day of September, 2012:

Resolved: That the signature of an Authorized Officer, the signature of the Secretary or the Assistant Secretary, and the Company seal may be affixed by facsimile to any power of attorney or to any certificate relating thereto appointing an Attorney-in-Fact for purposes only of executing and sealing any bond, undertaking, recognizance or other written obligation in the nature thereof, and any such signature and seal where so used, being hereby adopted by the Company as the original signature of such officer and the original seal of the Company, to be valid and binding upon the Company with the same force and effect as though manually affixed.

IN WITNESS WHEREOF, ATLANTIC SPECIALTY INSURANCE COMPANY has caused these presents to be signed by an Authorized Officer and the seal of the Company to be affixed this fifth day of March, 2020.



By *Paul J. Brehm*
Paul J. Brehm, Senior Vice President

STATE OF MINNESOTA
HENNEPIN COUNTY

On this fifth day of March, 2020, before me personally came Paul J. Brehm, Senior Vice President of ATLANTIC SPECIALTY INSURANCE COMPANY, to me personally known to be the individual and officer described in and who executed the preceding instrument, and he acknowledged the execution of the same, and being by me duly sworn, that he is the said officer of the Company aforesaid, and that the seal affixed to the preceding instrument is the seal of said Company and that the said seal and the signature as such officer was duly affixed and subscribed to the said instrument by the authority and at the direction of the Company.

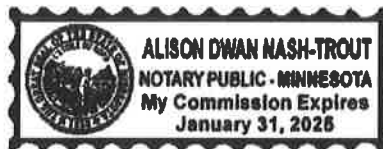

Alison Nash-Trout
Notary Public

I, the undersigned, Assistant Secretary of ATLANTIC SPECIALTY INSURANCE COMPANY, a New York Corporation, do hereby certify that the foregoing power of attorney is in full force and has not been revoked, and the resolutions set forth above are now in force.

Signed and sealed. Dated 21st day of April, 2023.



Christopher V. Jerry
Christopher V. Jerry, Secretary



Illinois Department of Transportation

Local Public Agency Formal Contract



Contractor's Name

Superior Road Striping, Inc.

Contractor's Address

1980 N. Hawthorne Ave.

City

Melrose Park

State

IL

Zip Code

60160

STATE OF ILLINOIS

Local Public Agency

County of DuPage

County

DuPage

Section Number

23-PVMG-11-GM

Street Name/Road Name

2023 Pavement Marking Maintenance

Type of Funds

Motor Fuel Tax

CONTRACT BOND (when required)

For a County and Road District Project

Submitted/Approved

Highway Commissioner Signature

Date

Signature and Date boxes for Highway Commissioner

Submitted/Approved

County Engineer/Superintendent of Highways

Date

Signature and Date boxes for County Engineer/Superintendent of Highways

For a Municipal Project

Submitted/Approved/Passed

Signature

Date

Signature and Date boxes for Municipal Project

Official Title

Official Title box for Municipal Project

Department of Transportation

Concurrence in approval of award

Regional Engineer Signature

Date

Signature and Date boxes for Department of Transportation

Local Public Agency	Local Street/Road Name	County	Section Number
County of DuPage	2023 Pavement Marking Maintenance	DuPage	22-PVMKG-11-GM

1. THIS AGREEMENT, made and concluded the _____ day of _____ between the County _____ of DuPage _____, known as the party of the first part, and Superior Road Striping, Inc. _____, its successor, and assigns, known as the party of the second part.

2. For and in consideration of the payments and agreements mentioned in the Proposal hereto attached, to be made and performed by the party of the first part, and according to the terms expressed in the Bond referring this contract, the party of the second part agrees with said party of the first part, at its own proper cost and expense, to do all the work, furnish all materials and all labor necessary to complete the work in accordance with the plans and specifications hereinafter described, and in full compliance with all of the terms of this contract.

3. It is also understood and agreed that the LPA Formal Contract Proposal, Special Provisions, Affidavit of Illinois Business Office, Apprenticeship or Training Program Certification, and Contract Bond hereto attached, and the Plans for Section 22-PVMKG-11-GM in County of DuPage _____, approved by the Illinois Department of Transportation on _____, are essential documents of this contract and are a part hereof.

4. IN WITNESS WHEREOF, the said parties have executed this contract on the date above mentioned.

Attest: The _____ County _____ of DuPage _____

Clerk _____ Date 5-9-23

(SEAL)



(SEAL)

Attest: Secretary _____ Date 4-24-23

(SEAL)

Party of the First Part _____ Date 5-9-23

(If a Corporation)

Corporate Name Superior Road Striping, Inc.

President, Party of the Second Part _____ Date 4-24-23

(If a Limited Liability Corporation)

LLC Name _____

Manager or Authorized Member, Party of the Second Part _____

(If a Partnership)

Partner _____ Date _____

Partner _____ Date _____

Partners doing Business under the firm name of Party of the Second Part _____

(If an Individual)

Party of the Second Part _____ Date _____



**Local Public Agency
Formal Contract Proposal**

COVER SHEET

Proposal Submitted By:
 Contractor's Name
 Superior Road Striping, Inc.
 Contractor's Address
 1980 N. Hawthorne Ave.
 City
 Melrose Park
 State
 IL
 Zip Code
 60160

STATE OF ILLINOIS
 Local Public Agency
 County of DuPage
 County
 DuPage
 Section Number
 23-PVMKG-11-GM
 Route(s) (Street/Road Name)
 2023 Pavement Marking Maintenance
 Type of Funds
 Motor Fuel Tax

Proposal Only Proposal and Plans Proposal only, plans are separate

Submitted/Approved
For Local Public Agency:

For a County and Road District Project

Submitted/Approved

Highway Commissioner Signature Date

County Engineer/Superintendent of Highways Date

For a Municipal Project

Submitted/Approved/Passed

Signature Date

Official Title

Department of Transportation

Released for bid based on limited review

Regional Engineer Signature Date

*County Engineer
 on behalf of IDOT pursuant to
 Agreement of Understanding
 Dated August 7, 2012*

Note: All proposal documents, including Proposal Guaranty Checks or Proposal Bid Bonds, should be stapled together to prevent loss when bids are processed.

Local Public Agency	County	Section Number	Route(s) (Street/Road Name)
County of DuPage	DuPage	23-PVMKG-11-GM	2023 Pavement Marking Maintenance

NOTICE TO BIDDERS

Sealed proposals for the project described below will be received at the office of the DuPage County Division of Transportation
421 N. County Farm Road, 2nd Floor, Wheaton, IL 60187 until 2:00 PM on 03-14-23
Address Time Date

Sealed proposals will be opened and read publicly at the office of the DuPage County Division of Transportation
421 N. County Farm Road, 2nd Floor, Wheaton, IL 60187 at 2:00 PM on 03-14-23
Address Time Date

DESCRIPTION OF WORK

Location	Project Length
Various County Routes	
Proposed Improvement	
Removal of existing pavement markings and installation of thermoplastic, urethane, and spray thermoplastic pavement markings, and recessed pavement markers.	

1. Plans and proposal forms will be available in the office of
on line at <http://www.dupageco.org/dot/doingbusiness>
or by contacting the Division of Transportation at (630) 407-6900.

2. ■ Prequalification
 If checked, the 2 apparent as read low bidders must file within 24 hours after the letting an "Affidavit of Availability" (Form BC 57) in triplicate, showing all uncompleted contracts awarded to them and all low bids pending award for Federal, State, County, Municipal and private work. One original shall be filed with the Awarding Authority and two originals with the IDOT District Office.
3. The Awarding Authority reserves the right to waive technicalities and to reject any or all proposals as provided in BLRS Special Provision for Bidding Requirements and Conditions for Contract Proposals.
4. The following Forms shall be returned by the bidder to the Awarding Authority:
 - a. Local Public Agency Formal Contract Proposal (BLR 12200)
 - b. Schedule of Prices (DuPage County version of BLR 12201)
 - c. Proposal Bid Bond (BLR 12230)
 - d. **DuPage County Apprenticeship or Training Program Certification (all Apprenticeship/Training Registration Number(s) and/or Certificate(s) need to be included with this form)**
 - e. Affidavit of Illinois Business Office (BLR 12326) (do not use for project with Federal funds)
 - f. **DuPage County - Required Vendor Ethics Disclosure Statement**
 - g. **IRS Form W-9: Request for Taxpayer Identification Number and Certification**
 - h. **Three (3) References Form**
 - i. **Joint Purchasing Authorization**
5. The quantities appearing in the bid schedule are approximate and are prepared for the comparison of bids. Payment to the Contractor will be made only for the actual quantities of work performed and accepted or materials furnished according to the contract. The scheduled quantities of work to be done and materials to be furnished may be increased, decreased or omitted as hereinafter provided.
6. Submission of a bid shall be conclusive assurance and warranty the bidder has examined the plans and understands all requirements for the performance of work. The bidder will be responsible for all errors in the proposal resulting from failure or neglect to conduct an in depth examination. The Awarding Authority will, in no case, be responsible for any costs, expenses, losses or changes in anticipated profits resulting from such failure or neglect of the bidder.
7. The bidder shall take no advantage of any error or omission in the proposal and advertised contract.
8. If a special envelope is supplied by the Awarding Authority, each proposal should be submitted in that envelope furnished by the Awarding Agency and the blank spaces on the envelope shall be filled in correctly to clearly indicate its contents. When an envelope other than the special one furnished by the Awarding Authority is used, it shall be marked to clearly indicate its contents. When sent by mail, the sealed proposal shall be addressed to the Awarding Authority at the address and in care of the official in whose office the bids are to be received. All proposals shall be filed prior to the time and at the place specified in the Notice to Bidders. Proposals received after the time specified will be returned to the bidder unopened.
9. Permission will be given to a bidder to withdraw a proposal if the bidder makes the request in writing or in person before the time for opening proposals.

Local Public Agency	County	Section Number	Route(s) (Street/Road Name)
County of DuPage	DuPage	23-PVMKG-11-GM	2023 Pavement Marking Maintenance

PROPOSAL

- Proposal of Superior Road Striping, Inc.
 Contractor's Name
1980 N. Hawthorne Ave. Melrose Park, IL 60160
 Contractor's Address
- The plans for the proposed work are those prepared by DuPage County Division of Transportation and approved by the Department of Transportation on _____.
- The specifications referred to herein are those prepared by the Department of Transportation and designated as "Standard Specifications for Road and Bridge Construction" and the "Supplemental Specifications and Recurring Special Provisions" thereto, adopted and in effect on the date of invitation for bids.
- The undersigned agrees to accept, as part of the contract, the applicable Special Provisions indicated on the "Check Sheet for Recurring Special Provisions" contained in this proposal.
- The undersigned agrees to complete the work within _____ working days or by 8/11/23* & 11/30/23** unless additional time is granted in accordance with the specifications.
- The successful bidder at the time of execution of the contract will be required to deposit a contract bond for the full amount of the award. When a contract bond is not required, the proposal guaranty check will be held in lieu thereof. If this proposal is accepted and the undersigned fails to execute a contract and contract bond as required, it is hereby agreed that the Bid Bond of check shall be forfeited to the Awarding Authority.
- Each pay item should have a unit price and a total price. If no total price is shown or if there is a discrepancy between the products of the unit price multiplied by the quantity, the unit price shall govern. If a unit price is omitted, the total price will be divided by the quantity in order to establish a unit price. A bid may be declared unacceptable if neither a unit price nor a total price is shown.
- The undersigned submits herewith the schedule of prices on BLR 12201 covering the work to be performed under this contract.
- The undersigned further agrees that if awarded the contract for the sections contained in the combinations on BLR 12201, the work shall be in accordance with the requirements of each individual proposal for the multiple bid specified in the Schedule for Multiple Bids below.
- A proposal guaranty in the proper amount, as specified in BLRS Special Provision for Bidding Requirements and Conditions for Contract Proposals, will be required. Bid Bonds will be allowed as a proposal guaranty. Accompanying this proposal is either a bid bond, if allowed, on Department form BLR 12230 or a proposal guaranty check, complying with the specifications, made payable to: County Treasurer of DuPage.
 The amount of the check is _____.

Attach Cashier's Check or Certified Check Here

In the event that one proposal guaranty check is intended to cover two or more bid proposals, the amount must be equal to the sum of the proposal guaranties which would be required for each individual bid proposal. If the proposal guaranty check is placed in another bid proposal, state below where it may be found.

The proposal guaranty check will be found in the bid proposal for: Section Number 23-PVMKG-11-GM.

Local Public Agency	County	Section Number	Route(s) (Street/Road Name)
County of DuPage	DuPage	23-PVMKG-11-GM	2023 Pavement Marking Maintenance

CONTRACTOR CERTIFICATIONS

The certifications hereinafter made by the bidder are each a material representation of fact upon which reliance is placed should the Department enter into the contract with the bidder.

- Debt Delinquency.** The bidder or contractor or subcontractor, respectively, certifies that it is not delinquent in the payment of any tax administered by the Department of Revenue unless the individual or other entity is contesting, in accordance with the procedure established by the appropriate Revenue Act, its liability for the tax or the amount of the tax. Making a false statement voids the contract and allows the Department to recover all amounts paid to the individual or entity under the contract in a civil action.
- Bid-Rigging or Bid Rotating.** The bidder or contractor or subcontractor, respectively, certifies that it is not barred from contracting with the Department by reason of a violation of either 720 ILCS 5/33E-3 or 720 ILCS 5/33E-4.

A violation of section 33E-3 would be represented by a conviction of the crime of bid-rigging which, in addition to Class 3 felony sentencing, provides that any person convicted of this offense, or any similar offense of any state or the United States which contains the same elements as this offense shall be barred for 5 years from the date of conviction from contracting with any unit of State or local government. No corporation shall be barred from contracting with any unit of State or local government as a result of a conviction under this Section of any employee or agent of such corporation if the employee so convicted is no longer employed by the corporation: (1) it has been finally adjudicated not guilty or (2) if it demonstrates to the governmental entity with which it seeks to contract that entity finds that the commission of the offense was neither authorized, requested, commanded, nor performed by a director, officer or a high managerial agent on behalf of the corporation.

A violation of Section 33E-4 would be represented by a conviction of the crime of bid-rotating which, in addition to Class 2 felony sentencing, provides that any person convicted of this offense or any similar offense of any state or the United States which contains the same elements as this offense shall be permanently barred from contracting with any unit of State of Local government. No corporation shall be barred from contracting with any unit of State or Local government as a result of a conviction under this Section of any employee or agent of such corporation if the employee so convicted is no longer employed by the corporation and: (1) it has been finally adjudicated not guilty or (2) if it demonstrates to the governmental entity with which it seeks to contract and that entity finds that the commission of the offense was neither authorized, requested, commanded, nor performed by a director, officer or a high managerial agent on behalf of the corporation.

- Bribery.** The bidder or contractor or subcontractor, respectively, certifies that, it has not been convicted of bribery or attempting to bribe an officer or employee of the State of Illinois or any unit of local government, nor has the firm made an admission of guilt of such conduct which is a matter or record, nor has an official, agent, or employee of the firm committed bribery or attempted bribery on behalf of the firm and pursuant to the direction or authorization of a responsible official of the firm.
- Interim Suspension or Suspension.** The bidder or contractor or subcontractor, respectively, certifies that it is not currently under a suspension as defined in Subpart I of Title 44 Subtitle A Chapter III Part 6 of the Illinois Administrative code. Furthermore, if suspended prior to completion of this work, the contract or contracts executed for the completion of this work may be canceled.

Local Public Agency	County	Section Number	Route(s) (Street/Road Name)
County of DuPage	DuPage	23-PVMKG-11-GM	2023 Pavement Marking Maintenance

SIGNATURES

(If an individual)

Signature of Bidder	Date	
Business Address		
City	State	Zip Code

(If a partnership)

Firm Name		
Signature	Date	
Title		
Business Address		
City	State	Zip Code

Insert the Names and Addresses of all Partners

(If a corporation)

Corporate Name		
Superior Road Striping, Inc.		
Signature	Date	
	5-3-23	
Title		
President		
Business Address		
1980 N. Hawthorne Ave.		
City	State	Zip Code
Melrose Park	IL	60160

Insert Names of Officers

President
Joan Yario

Attest:

Secretary

Secretary

Joan Yario

Treasurer

Joseph Yario

RETURN WITH BID

**SCHEDULE OF PRICES
(BASE BID PLUS ALTERNATIVES C)**

Contractor's Name: Superior Road Striping, Inc.
 Local Public Agency: County of DuPage
 County: DuPage
 Section: 23-PVMKG-11-GM
 Route: 2023 Pavement Marking
Maintenance

Schedule for Multiple Bids

Combination Letter	Sections included in Combinations	Total

Schedule for Single Bid

(For complete information covering these items, see plans and specifications)

Item No.	Items	Unit	Quantity	Unit Price	Total
1	THERMOPLASTIC PAVEMENT MARKING - LETTERS AND SYMBOLS	SQ FT	14474	\$5.00	72,370.00
2	THERMOPLASTIC PAVEMENT MARKING - LINE 4"	FOOT	13109	\$0.70	9,176.30
3	THERMOPLASTIC PAVEMENT MARKING - LINE 6"	FOOT	49954	\$1.00	49,954.00
4	THERMOPLASTIC PAVEMENT MARKING - LINE 8"	FOOT	16346	\$1.40	22,884.40
5	THERMOPLASTIC PAVEMENT MARKING - LINE 12"	FOOT	27982	\$2.00	55,964.00
6	THERMOPLASTIC PAVEMENT MARKING - LINE 24"	FOOT	5373	\$5.00	26,865.00
7	HOT SPRAY THERMOPLASTIC PAVEMENT MARKING LINE - 4 INCH	FOOT	436140	\$0.34	148,287.60
8	MODIFIED URETHANE PAVEMENT MARKING - LETTERS AND SYMBOLS	SQ FT	718	\$6.00	4,308.00
9	MODIFIED URETHANE PAVEMENT MARKING - LINE 4"	FOOT	19476	\$0.90	17,528.40
10	MODIFIED URETHANE PAVEMENT MARKING - LINE 6"	FOOT	3442	\$1.00	3,442.00
11	MODIFIED URETHANE PAVEMENT MARKING - LINE 8"	FOOT	54	\$1.50	81.00
12	MODIFIED URETHANE PAVEMENT MARKING - LINE 12"	FOOT	440	\$2.00	880.00
13	MODIFIED URETHANE PAVEMENT MARKING - LINE 24"	FOOT	180	\$6.00	1,080.00
14	MODIFIED URETHANE PAVEMENT MARKING - RAISED MEDIAN	SQ FT	3687	\$3.25	11,982.75
15	PAVEMENT MARKING REMOVAL - GRINDING	SQ FT	95043	\$0.50	47,521.50
16	RECESSED REFLECTIVE PAVEMENT MARKER	EACH	500	\$35.00	17,500.00

RETURN WITH BID

17	REPLACEMENT REFLECTOR	EACH	500	\$10.00	5,000.00
18	TEMPORARY PAVEMENT MARKING REMOVAL	FOOT	800	\$1.00	800.00
Bidder's Proposal for making entire improvements (Base + Alternative C)					\$495,624.95

1. Each pay item should have a unit price and a total price.
2. If no total price is shown or if there is a discrepancy between the product of the unit price multiplied by the quantity, the unit price shall govern.
3. If a unit price is omitted, the total price will be divided by the quantity in order to establish a unit price.
4. A bid may be declared unacceptable if neither a unit price or total price is shown.

RETURN WITH BID

SCHEDULE OF PRICES
(BASE BID)

Contractor's Name: Superior Road Striping, Inc.
 Local Public Agency: County of DuPage
 County: DuPage
 Section: 23-PVMKG-11-GM
 Route: 2023 Pavement Marking
Maintenance

Schedule for Single Bid

(For complete information covering these items, see plans and specifications)

Item No.	Items	Unit	Quantity	Unit Price	Total
1	THERMOPLASTIC PAVEMENT MARKING - LETTERS AND SYMBOLS	SQ FT	14183	\$5.00	70,915.00
2	THERMOPLASTIC PAVEMENT MARKING - LINE 4"	FOOT	12308	\$0.70	8,615.60
3	THERMOPLASTIC PAVEMENT MARKING - LINE 6"	FOOT	48648	\$1.00	48,648.00
4	THERMOPLASTIC PAVEMENT MARKING - LINE 8"	FOOT	16346	\$1.40	22,884.40
5	THERMOPLASTIC PAVEMENT MARKING - LINE 12"	FOOT	26884	\$2.00	53,768.00
6	THERMOPLASTIC PAVEMENT MARKING - LINE 24"	FOOT	5174	\$5.00	25,870.00
7	HOT SPRAY THERMOPLASTIC PAVEMENT MARKING LINE - 4 INCH	FOOT	396488	\$0.34	134,805.92
8	MODIFIED URETHANE PAVEMENT MARKING - LETTERS AND SYMBOLS	SQ FT	718	\$6.00	4,308.00
9	MODIFIED URETHANE PAVEMENT MARKING - LINE 4"	FOOT	19476	\$0.90	17,528.40
10	MODIFIED URETHANE PAVEMENT MARKING - LINE 6"	FOOT	3442	\$1.00	3,442.00
11	MODIFIED URETHANE PAVEMENT MARKING - LINE 8"	FOOT	54	\$1.50	81.00
12	MODIFIED URETHANE PAVEMENT MARKING - LINE 12"	FOOT	440	\$2.00	880.00
13	MODIFIED URETHANE PAVEMENT MARKING - LINE 24"	FOOT	180	\$6.00	1,080.00
14	MODIFIED URETHANE PAVEMENT MARKING - RAISED MEDIAN	SQ FT	3687	\$3.25	11,982.75
15	PAVEMENT MARKING REMOVAL - GRINDING	SQ FT	92603	\$0.50	46,301.50
16	RECESSED REFLECTIVE PAVEMENT MARKER	EACH	500	\$35.00	17,500.00
17	REPLACEMENT REFLECTOR	EACH	500	\$10.00	5,000.00
18	TEMPORARY PAVEMENT MARKING REMOVAL	FOOT	800	\$1.00	800.00
Bidder's Proposal for making entire improvements (Base Bid only)				\$474,410.57	

RETURN WITH BID

SCHEDULE OF PRICES
(ALT. C)

Contractor's Name: Superior Road Striping, Inc.
 Local Public Agency: County of DuPage
 County: DuPage
 Section: 23-PVMKG-11-GM
 Route: 2023 Pavement Marking
Maintenance

Schedule for Single Bid

(For complete information covering these items, see plans and specifications)

Item No.	Items	Unit	Quantity	Unit Price	Total
1	THERMOPLASTIC PAVEMENT MARKING - LETTERS AND SYMBOLS	SQ FT	291	\$5.00	1,455.00
2	THERMOPLASTIC PAVEMENT MARKING - LINE 4"	FOOT	801	\$0.70	560.70
3	THERMOPLASTIC PAVEMENT MARKING - LINE 6"	FOOT	1306	\$1.00	1,306.00
4	THERMOPLASTIC PAVEMENT MARKING - LINE 8"	FOOT		\$1.40	
5	THERMOPLASTIC PAVEMENT MARKING - LINE 12"	FOOT	1098	\$2.00	2,196.00
6	THERMOPLASTIC PAVEMENT MARKING - LINE 24"	FOOT	199	\$5.00	995.00
7	HOT SPRAY THERMOPLASTIC PAVEMENT MARKING LINE - 4 INCH	FOOT	39652	\$0.34	13,481.68
8	MODIFIED URETHANE PAVEMENT MARKING - LETTERS AND SYMBOLS	SQ FT		\$6.00	
9	MODIFIED URETHANE PAVEMENT MARKING - LINE 4"	FOOT		\$0.90	
10	MODIFIED URETHANE PAVEMENT MARKING - LINE 6"	FOOT		\$1.00	
11	MODIFIED URETHANE PAVEMENT MARKING - LINE 8"	FOOT		\$1.50	
12	MODIFIED URETHANE PAVEMENT MARKING - LINE 12"	FOOT		\$2.00	
13	MODIFIED URETHANE PAVEMENT MARKING - LINE 24"	FOOT		\$6.00	
14	MODIFIED URETHANE PAVEMENT MARKING - RAISED MEDIAN	SQ FT		\$3.25	
15	PAVEMENT MARKING REMOVAL - GRINDING	SQ FT	2440	\$0.50	1,220.00
16	RECESSED REFLECTIVE PAVEMENT MARKER	EACH		\$35.00	
17	REPLACEMENT REFLECTOR	EACH		\$10.00	
18	TEMPORARY PAVEMENT MARKING REMOVAL	FOOT		\$1.00	
Bidder's Proposal for making entire improvements (Alt. C)					\$21,214.38

RETURN WITH BID

**SCHEDULE OF PRICES
(BID SUMMARY)**

Contractor's Name: Superior Road Striping, Inc.
 Local Public Agency: County of DuPage
 County: DuPage
 Section: DuPage
 Route: 23-PVMKG-11-GM
2023 Pavement Marking

BID SUMMARY

BASE BID TOTAL	\$474,410.57
ALT. C TOTAL	\$21,214.38
BASE BID + ALT. C	\$495,624.95



Apprenticeship and Training Program Certification

RETURN WITH BID

Local Public Agency	County	Street Name/Road Name	Section Number
County of DuPage	DuPage	Various County Routes	23-PVMKG-11-GM

All contractors are required to complete the following certification

- For this contract proposal or for all bidding groups in this deliver and install proposal.
- For the following deliver and install bidding groups in this material proposal.

The County of DuPage policy, adopted in accordance with DuPage County, Illinois County Code, requires this contract to be awarded to the lowest responsive and responsible bidder. The award decision is subject to approval by the Department. In addition to all other responsibility factors, this contract or deliver and install proposal requires all bidders and all bidder's subcontractors to disclose participation in apprenticeship or training programs that are (1) approved by and registered with the United States Department of Labor's Bureau of Apprenticeship and Training, and (2) applicable to the work of the above indicated proposals or groups. Therefore, all bidders are required to complete the following certification:

- Except as provided in paragraph 4 below, the undersigned bidder certifies that it is a participant, either as an individual or as part of a group program, in an approved apprenticeship or training program applicable to each type of work or craft that the bidder will perform with its own employees.
- The undersigned bidder further certifies, for work to be performed by subcontract, that each of its subcontractors either (A) is, at the time of such bid, participating in an approved, applicable apprenticeship or training program; or (B) will, prior to commencement of performance of work pursuant to this contract, establish participation in an approved apprenticeship or training program applicable to the work of the subcontract.
- The undersigned bidder, by inclusion in the list in the space below, certifies the official name of each program sponsor holding the Certificate of Registration for all of the types of work or crafts in which the bidder is a participant and that will be performed with the bidder's employees. Types of work or craft that will be subcontracted shall be included and listed as subcontract work.

International Brotherhood of Teamsters, Local 786

- Except for any work identified above, if any bidder or subcontractor shall perform all or part of the work of the contract or deliver and install proposal solely by individual owners, partners or members and not by employees to whom the payment of prevailing rates of wages would be required, check the following box, and identify the owner/operator workforces and positions of ownership.

The requirements of this certification and disclosure are a material part of the contract, and the contractor shall require this certification provision to be included in all approved subcontracts. The bidder is responsible for making a complete report and shall make certain that each type of work or craft job category that will be utilized on the project is accounted for and listed. The Department at any time before or afterward may require the production of a copy of each applicable Certificate of Registration issued by the United States Department of Labor evidencing such participation by the contractor and any or all of its subcontractors. In order to fulfill the participation requirement, it shall not be necessary that any applicable program sponsor be currently taking or that it will take applications for apprenticeship, training or employment during the performance of the work of this contract or deliver and install proposal.

Bidder	Signature	Date	
Superior Road Striping, Inc.		5-3-23	
Title			
President			
Address	City	State	Zip Code
1980 N. Hawthorne Ave.	Melrose Park	IL	60160



Affidavit of Illinois Business Office



Local Public Agency County of DuPage	County DuPage	Street Name/Road Name 2023 Pavement Marking Maintenance	Section Number 23-PVMKG-11-GM
--	-------------------------	---	---

I, **Joan Yario** of **Bensenville**, **Illinois**
Name of Affiant City of Affiant State of Affiant

being first duly sworn upon oath, state as follows:

- That I am the **President** of **Superior Road Striping, Inc.**
Officer or Position Bidder
- That I have personal knowledge of the facts herein stated.
- That, if selected under the proposal described above, **Superior Road Striping, Inc.**, will maintain a business office in the State of Illinois, which will be located in **Cook** County, Illinois.
Bidder County
- That this business office will serve as the primary place of employment for any persons employed in the construction contemplated by this proposal.
- That this Affidavit is given as a requirement of state law as provided in Section 30-22(8) of the Illinois Procurement Code.

Signature 	Date 5-3-23
Print Name of Affiant Joan Yario	

Notary Public

State of IL
 County **DuPage**

Signed (or subscribed or attested) before me on **5-3-23** by
(date)

Joan Yario, authorized agent(s) of
(name/s of person/s)
Superior Road Striping, Inc.
Bidder

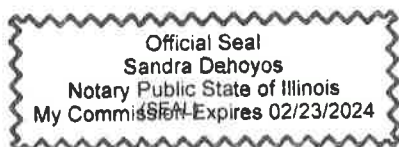

Signature of Notary Public

 My commission expires _____



Required Vendor Ethics Disclosure Statement

Failure to complete and return this form may result in delay or cancellation of the County's Contractual Obligation.

Date: _____

Bid/Contract/PO #: 23-PVMKG-11-GM

Company Name: _____	Company Contact: _____
Contact Phone: _____	Contact Email: _____

The DuPage County Procurement Ordinance requires the following written disclosures prior to award:

1. Every contractor, union, or vendor that is seeking or has previously obtained a contract, change orders to one (1) or more contracts, or two (2) or more individual contracts with the county resulting in an aggregate amount at or in excess of \$25,000, shall provide to Procurement Services Division a written disclosure of all political campaign contributions made by such contractor, union, or vendor within the current and previous calendar year to any incumbent county board member, county board chairman, or countywide elected official whose office the contract to be awarded will benefit. The contractor, union or vendor shall update such disclosure annually during the term of a multi-year contract and prior to any change order or renewal requiring approval by the county board. For purposes of this disclosure requirement, "contractor or vendor" includes owners, officers, managers, lobbyists, agents, consultants, bond counsel and underwriters counsel, subcontractors and corporate entities under the control of the contracting person, and political action committees to which the contracting person has made contributions.

NONE (check here) - If no contributions have been made

Recipient	Donor	Description (e.g. cash, type of item, in-kind services, etc.)	Amount/Value	Date Made

2. All contractors and vendors who have obtained or are seeking contracts with the county shall disclose the names and contact information of their lobbyists, agents and representatives and all individuals who are or will be having contact with county officers or employees in relation to the contractor bid and shall update such disclosure with any changes that may occur.

NONE (check here) - If no contacts have been made

Lobbyists, Agents and Representatives and all individuals who are or will be having contact with county officers or employees in relation to the contract or bid	Telephone	Email

A contractor or vendor that knowingly violates these disclosure requirements is subject to penalties which may include, but are not limited to, the immediate cancellation of the contract and possible disbarment from future county contracts.

Continuing disclosure is required, and I agree to update this disclosure form as follows:

- If information changes, within five (5) days of change, or prior to county action, whichever is sooner
- 30 days prior to the optional renewal of any contract
- Annual disclosure for multi-year contracts on the anniversary of said contract
- With any request for change order except those issued by the county for administrative adjustments

The full text for the county's ethics and procurement policies and ordinances are available at:

<http://www.dupageco.org/CountyBoard/Policies/>

I hereby acknowledge that I have received, have read, and understand these requirements.

Authorized Signature 

Printed Name Joan Yario

Title President

Date 5-3-23

Attach additional sheets if necessary. Sign each sheet and number each page. Page _____ of _____ (total number of pages)

2023 PAVEMENT MARKING MAINTENANCE
SEC. 23-PVMKG-11-GM

REFERENCES

All bidders must provide three (3) projects of a similar nature as being performed in the immediate past five (5) years with the name, address and telephone number of the contact person having knowledge of the project or three (3) references (name, address, and telephone number) with knowledge of the integrity and business practices of the contractor.

PROJECT	Contract 46604
FIRM	IDOT
ADDRESS	2300 S. Dirksen Parkway Springfield
CONTACT	Pat Kenenakhone
TELEPHONE	847-562-6196

PROJECT	Pavement Marking
FIRM	McHenry Co D.O.T.
ADDRESS	1611 Nelson Rd Woodstock
CONTACT	Brad Cousin
TELEPHONE	815-482-2867

PROJECT	Pavement Marking
FIRM	CITY OF JOLIET
ADDRESS	150 W Jefferson Joliet
CONTACT	Russ Labash
TELEPHONE	815-671-2007

RETURN WITH BID

Joint Purchasing Authorization

County	DuPage
Local Public Agency	DuPage County D.O.T
Section Number	23-PVMKG-11-GM
Route	2023 Pavement Marking Maintenance

JOINT PURCHASING:

OTHER TAXING BODIES: Based on County Board Resolution IR-084-76.

Would your firm be willing to extend your bid to other taxing bodies in DuPage County such as school districts, townships, cities and villages, etc.?
The approximate quantity usage is unknown.

YES X NO **

**** Failure to complete this form will result in a default assumption of a "NO" response.**

State any other requirements that they would have to meet beyond that of our Bid Invitation and Specifications.

 \$ 5,000.00 min.

NOTE: The County of DuPage would not be involved in purchasing by any other taxing body other than to receive a copy of their purchase order that would reference the County of DuPage contract number. The invoicing and payments would be entirely between the other taxing bodies and the Contractor. If the County of DuPage accepts this bid, the procedure to handle joint purchases would be developed by the County of DuPage with the Contractor and distributed to the taxing bodies by the County of DuPage.

○ **TABLE OF CONTENTS**



SPECIAL PROVISIONS
2023 PAVEMNT MARKING MAINTENANCE
SEC. 23-PVMKG-11-GM

TABLE OF CONTENTS

PROPOSAL DOCUMENTS

- BLR 12200 Local Public Agency Formal Contract Proposal
 - COVER SHEET
 - NOTICE TO BIDDERS
 - PROPOSAL
 - CONTRACTOR CERTIFICATIONS
 - SIGNATURES
- BLR 12201 Schedule of Prices
- BLR 12230 Local Agency Proposal Bid Bond
- DuPage County Apprenticeship or Training Program Certification
- BLR 12326 Affidavit of Illinois Business Office
- BC 57 Affidavit of Availability
- DuPage County – Required Vendor Ethics Disclosure Statement
- IRS Form W-9: Request for Taxpayer Identification Number and Certification
- Three (3) references form
- Joint Purchasing Authorization

PAGE

PLANS **A**

 GENERAL NOTES..... A

 SUMMARY OF QUANTITIES..... D

 SCHEDULES OF QUANTITIES E

SPECIAL PROVISIONS **1**

 DESCRIPTION OF WORK..... 1

 BIDDING DETAILS..... 1

 BIDDING REQUIREMENTS AND CONDITIONS FOR CONTRACT PROPOSALS..... 2

ADDED ALTERNATIVE BIDDING 2

ADD ALTERNATIVE BIDDING – LOW BIDDER DETERMINATION EXAMPLES 3

 SECTION 107 LEGAL REGULATIONS AND RESPONSIBILITY TO PUBLIC 4

 SECTION 108 PROSECUTION AND PROGRESS 5

 SECTION 109 MEASUREMENT AND PAYMENT 6

 SECTION 671 MOBILIZATION 6

 SECTION 1105 PAVEMENT MARKING EQUIPMENT 6

 CALENDAR DAY REQUIREMENTS 6

 TRAFFIC CONTROL AND PROTECTION 6

 TRAFFIC CONTROL PLAN 7

 RECESSED REFLECTIVE PAVEMENT MARKERS 8

 45 MIL HOT SPRAY THERMOPLASTIC PAVEMENT MARKING 8

 MODIFIED URETHANE PAVEMENT MARKING – RAISED MEDIAN 16

 TEMPORARY PAVEMENT MARKING REMOVAL 16

- Index For Supplemental Specifications And Recurring Special Provisions
- Check Sheet For Recurring Special Provisions
- Check Sheet For Recurring Local Roads And Streets Special Provisions

DuPage County Prevailing Wage effective January 18, 2023 (for use with LRS Check Sheet #12)

Local Roads and Streets Special Provisions

SPECIAL PROVISIONS
2023 PAVEMNT MARKING MAINTENANCE
SEC. 23-PVMKG-11-GM

LR 702 Construction and Maintenance Signs

BDE Special Provisions

- Compensable Delay Costs
- Construction Air Quality – Diesel Retrofit
- Subcontractor and DBE Payments
- Subcontractor Mobilization Payments
- Work Zone Traffic Control Devices

Metra

- Application for Right of Entry
- Exhibit C – Metra’s Insurance Requirements

Highway Standard Drawings

- 701201 Lane Closure, 2L, 2W, Day Only, for Speeds > 45 MPH
- 701301 Lane Closure, 2L, 2W, Short Time Operations
- 701306 Lane Closure, 2L, 2W, Slow Moving Operations Day Only, for Speeds > 45 MPH
- 701311 Lane Closure, 2L, 2W, Moving Operations - Day Only
- 701336 Lane Closure, 2L, 2W, Work Areas in Series, for Speeds > 45 MPH
- 701421 Lane Closure, Multilane, Day Operations Only, for Speeds > 45 MPH to 55 MPH
- 701422 Lane Closure, Multilane, for Speeds > 45 MPH to 55 MPH
- 701426 Lane Closure, Multilane, Intermittent or Moving Operation, for Speeds > 45 MPH
- 701427 Lane Closure, Multilane, Intermittent or Moving Operation, for Speeds ≤ 40 MPH
- 701431 Lane Closure, Multilane, Undivided with Crossover, for Speeds > 45 MPH to 55 MPH
- 701501 Urban Lane Closure, 2L, 2W, Undivided
- 701502 Urban Lane Closure, 2L, 2W, with Bidirectional Left Turn Lane
- 701601 Urban Lane Closure, Multilane, 1W or 2W with Nontraversable Median
- 701602 Urban Lane Closure, Multilane, 2W with Bidirectional Left Turn Lane
- 701606 Urban Single Lane Closure, Multilane, 2W with Mountable Median
- 701611 Urban Half Road Closure, Multilane, 2W with Mountable Median
- 701701 Urban Lane Closure, Multilane Intersection
- 701801 Lane Closure, Multilane 1W or 2W Crosswalk or Sidewalk Closure
- 701901 Traffic Control Devices
- 781001 Typical Applications Raised Reflective Pavement Markers
- TC-10 TRAFFIC CONTROL AND PROTECTION FOR SIDE ROADS, INTERSECTIONS, AND DRIVEWAYS
- TC-11 TYPICAL APPLICATIONS RAISED REFLECTIVE PAVEMENT MARKERS (SNOWPLOW RESISTANT)
- TC-13 DISTRICT ONE TYPICAL PAVEMENT MARKINGS
- TC-14 TRAFFIC CONTROL AND PROTECTION AT TURN BAYS (TO REMAIN OPEN TO TRAFFIC)
- RECESSED PAVEMENT MARKER

SPECIAL PROVISIONS
2023 PAVEMNT MARKING MAINTENANCE
SEC. 23-PVMKG-11-GM

PLANS

GENERAL NOTES

GENERAL

DESCRIPTIONS OF THE PL AND LOR WORK CATEGORIES ARE PROVIDED IN THE PROJECT SPECIAL PROVISIONS.

NO WORK SHALL COMMENCE UNTIL TRAFFIC CONTROL REQUIREMENTS ARE MET.

UNLESS AUTHORIZED BY THE ENGINEER, ALL EXISTING ACCESS POINTS SHALL BE MAINTAINED AT ALL TIMES BY THE CONTRACTOR.

ALL PAVEMENT MARKING ON COUNTY HIGHWAYS SHALL BE INSTALLED COMPLETELY AND TO LOGICAL TERMINII, UNLESS OTHERWISE DIRECTED BY THE ENGINEER. PL QUANTITIES IN THE SCHEDULE OF QUANTITIES ARE ESTIMATED AND THE ACTUAL QUANTITIES MAY BE ADJUSTED AS DIRECTED BY THE ENGINEER ACCORDING TO FIELD CONDITIONS OR THE NEEDS OF THE DUPAGE COUNTY DIVISION OF TRANSPORTATION. PAYMENT WILL BE MADE BASED ON ACTUAL INSTALLED QUANTITIES.

ALL MARKINGS SHALL BE INSTALLED ACCORDING TO THE MANUAL ON UNIFORM TRAFFIC CONTROL DEVICES (MUTCD), 2009 EDITION AND THE SPECIAL PROVISIONS AND NOTES HEREIN REGARDLESS OF THE EXISTING CONFIGURATION. ANY NON-CONFORMING MARKINGS INSTALLED WITHOUT PRIOR APPROVAL OF THE TRAFFIC ENGINEER SHALL BE REMOVED AND CONFORMING MARKINGS INSTALLED BY THE CONTRACTOR AT NO ADDITIONAL COST TO THE COUNTY.

THE CONTRACTOR SHALL SUBMIT AN ESTIMATED WORK SCHEDULE TO THE ENGINEER BEFORE BEGINNING WORK. THE CONTRACTOR'S SCHEDULE SHALL INCLUDE NO MORE THAN SEVEN (7) CALENDAR DAYS BETWEEN SCHEDULED WORK ACTIVITIES.

THE CONTRACTOR SHALL NOTE THAT MANDATORY TURN LANE LINES SHALL BE MARKED WITH TRANSVERSE SKIP DASHES IN ACCORDANCE WITH MUTCD FIGURE 3B.24. TAPERED OR DIAGONAL SKIP DASHES APPROACHING MANDATORY TURN LANES WILL NOT BE ALLOWED UNLESS DIRECTED BY THE TRAFFIC ENGINEER.

THE CONTRACTOR SHALL NOTE THAT ALL CROSSWALKS SHALL BE IN CONTINENTAL (BAR) CONFIGURATION EXCEPT AS DIRECTED BY THE ENGINEER.

"LOCATION ON REQUEST (LOR)" QUANTITIES WILL BE USED FOR INSTALLING MARKINGS AT ADDITIONAL LOCATIONS NOT OTHERWISE INCLUDED IN THIS CONTRACT AS DIRECTED BY THE ENGINEER. THESE QUANTITIES WILL BE USED AS NECESSARY COUNTY-WIDE TO MEET THE NEEDS OF THE DUPAGE COUNTY DIVISION OF TRANSPORTATION. THE LOCATION, TIMING, AND GROUPING OF PROJECT ASSIGNMENTS SHALL BE AT THE DISCRETION OF THE ENGINEER. WORK PERFORMED UNDER LOR QUANTITIES SHALL BE COMPLETED BY THE CONTRACTOR UPON REQUEST OF THE ENGINEER. THE CONTRACTOR SHALL BEGIN ASSIGNED LOR WORK WITHIN 14 CALENDAR DAYS OF NOTIFICATION BY THE ENGINEER. THE COST TO MOBILIZE OR OTHERWISE PERFORM WORK AT SMALL OR DISTANT PROJECT SITES, OR UNDER UNANTICIPATED CIRCUMSTANCES, SHALL NOT BE PAID FOR SEPARATELY BUT SHALL BE INCLUDED IN THE UNIT PRICES PAY ITEMS.

SPECIAL PROVISIONS
2023 PAVEMENT MARKING MAINTENANCE
SEC. 23-PVMKG-11-GM

TRAFFIC CONTROL AND PROTECTION

TRAFFIC CONTROL AND PROTECTION SHALL BE PERFORMED IN ACCORDANCE WITH THE TRAFFIC CONTROL PLAN, TRAFFIC SIGNAL PLANS, THESE NOTES, APPLICABLE SPECIAL PROVISIONS, AND SECTION 701 OF THE STANDARD SPECIFICATIONS AS AMENDED BY THE SPECIAL PROVISION FOR WORK ZONE TRAFFIC CONTROL (CHECK SHEET LRS 3).

THE TYPE III BARRICADES ARE TO BE PLACED IN ACCORDANCE WITH STANDARD 701901 UNLESS AUTHORIZED BY THE ENGINEER TO USE AN ALTERNATE ARRANGEMENT.

TYPE I OR TYPE II BARRICADES, DRUMS, OR VERTICAL PANELS WITH MONODIRECTIONAL STEADY-BURN LIGHTS SHALL BE REQUIRED ALONG TEMPORARY ROADS, DETOURS, AND SIDE STREETS TO DELINEATE THE TRAVELED WAY WITHIN THE CONSTRUCTION ZONE. THE MAXIMUM SPACING FOR THESE DEVICES SHALL BE 100 FEET CENTER TO CENTER.

BARRICADES THAT MUST BE PLACED IN EXCAVATED AREAS SHALL HAVE LEG EXTENSIONS INSTALLED SUCH THAT THE TOP OF THE BARRICADE IS IN COMPLIANCE WITH THE HEIGHT REQUIREMENTS OF STANDARD 701901.

TYPE I OR TYPE II BARRICADES WITH TWO-WAY FLASHING LIGHTS SHALL BE REQUIRED AT ALL OPEN TRENCHES, EXCAVATIONS, OPEN OR EXPOSED SEWER STRUCTURES, TRANSVERSE PAVEMENT JOINTS, MATERIALS OR EQUIPMENT WITHIN THE RIGHT-OF-WAY (NUMBER AND SPACING DEPENDS ON THE CONDITIONS); AND AT LOCATIONS DESIGNATED BY THE ENGINEER OR LOCAL LAW ENFORCEMENT AGENCIES.

TYPE I, II AND / OR III BARRICADES WITH TWO-WAY FLASHING LIGHTS WILL BE REQUIRED TO GUIDE TRAFFIC AWAY FROM PAVEMENT AREAS CLOSED FOR CONSTRUCTION.

WHERE REQUIRED, TRAFFIC SIGNS SHALL BE RELOCATED FOR EACH STAGE OF CONSTRUCTION.

ARROW BOARDS WILL BE REQUIRED WHEN IMPLEMENTING ALL LANE CLOSURES.

SPECIAL PROVISIONS
2023 PAVEMNT MARKING MAINTENANCE
SEC. 23-PVMKG-11-GM

THE FOLLOWING TRAFFIC CONTROL STANDARDS ARE THE MINIMUM REQUIREMENTS FOR THE TRAFFIC CONTROL FOR THIS PROJECT:

- 701201 Lane Closure, 2L, 2W, Day Only, for Speeds > 45 MPH
- 701301 Lane Closure, 2L, 2W, Short Time Operations
- 701306 Lane Closure, 2L, 2W, Slow Moving Operations Day Only, for Speeds > 45 MPH
- 701311 Lane Closure, 2L, 2W, Moving Operations - Day Only
- 701336 Lane Closure, 2L, 2W, Work Areas in Series, for Speeds > 45 MPH
- 701421 Lane Closure, Multilane, Day Operations Only, for Speeds > 45 MPH to 55 MPH
- 701422 Lane Closure, Multilane, for Speeds > 45 MPH to 55 MPH
- 701426 Lane Closure, Multilane, Intermittent or Moving Operation, for Speeds > 45 MPH
- 701427 Lane Closure, Multilane, Intermittent or Moving Operation, for Speeds ≤ 40 MPH
- 701431 Lane Closure, Multilane, Undivided with Crossover, for Speeds > 45 MPH to 55 MPH
- 701501 Urban Lane Closure, 2L, 2W, Undivided
- 701502 Urban Lane Closure, 2L, 2W, with Bidirectional Left Turn Lane
- 701601 Urban Lane Closure, Multilane, 1W or 2W with Nontraversable Median
- 701602 Urban Lane Closure, Multilane, 2W with Bidirectional Left Turn Lane
- 701606 Urban Single Lane Closure, Multilane, 2W with Mountable Median
- 701611 Urban Half Road Closure, Multilane, 2W with Mountable Median
- 701701 Urban Lane Closure, Multilane Intersection
- 701801 Lane Closure, Multilane 1W or 2W Crosswalk or Sidewalk Closure
- 701901 Traffic Control Devices
- 781001 Typical Applications Raised Reflective Pavement Markers
- TC-10 TRAFFIC CONTROL AND PROTECTION FOR SIDE ROADS, INTERSECTIONS, AND DRIVEWAYS
- TC-11 TYPICAL APPLICATIONS RAISED REFLECTIVE PAVEMENT MARKERS (SNOWPLOW RESISTANT)
- TC-13 DISTRICT ONE TYPICAL PAVEMENT MARKINGS
- TC-14 TRAFFIC CONTROL AND PROTECTION AT TURN BAYS (TO REMAIN OPEN TO TRAFFIC)
RECESSED PAVEMENT MARKER

○ **SPECIAL PROVISIONS**



SPECIAL PROVISIONS
2023 PAVEMNT MARKING MAINTENANCE
SEC. 23-PVMKG-11-GM

STATE OF ILLINOIS

SPECIAL PROVISIONS

The following Special Provisions supplement the "Standard Specifications for Road and Bridge Construction", adopted January 1, 2022, the latest edition of the "Manual on Uniform Traffic Control Devices for Streets and Highways", the "Manual of Test Procedures for Materials" in effect on the date of invitation for bids and the "Supplemental Specifications and Recurring Special Provisions" indicated on the Check Sheet included herein which apply to and govern the proposed improvement designated as Section 23-PVMKG-11-GM, and in case of conflict with any part or parts of said Specifications, the said Special Provisions shall take precedence and shall govern.

DESCRIPTION OF WORK

This contract includes two separate categories of pavement marking installation for markings on County Highways and other locations as directed by the Engineer.

PRESCRIBED LOCATIONS ("PL") pavement markings include identified project locations that the DuPage County Division of Transportation (DCDOT) intends to install under this project. These quantities are described as PL throughout the bidding documents. PL pavement markings are subject to a completion date as specified and the Contractor will be required to install complete markings throughout the indicated segments concluding at logical termini along the county highways. The project quantities are estimates and reflect the conditions observed by the Engineer at the time the bid documents were prepared. Any adjustments to quantities to add or include work areas that are located at or adjacent to the work sites listed in the PL quantity tables will be paid at pay item unit prices.

LOCATIONS ON REQUEST ("LOR") pavement markings include nominal quantities for unanticipated or unprescribed locations throughout the County Highway system that will be requested by the Engineer for on-demand installation. These quantities are described as LOR or throughout the bidding documents. LOR pavement markings are generally used to restore pavement markings damaged by highway maintenance or isolated areas where markings have worn prematurely. This work is subject to a unique completion date as specified and the Contractor will be required to mobilize and install the markings upon request of the Engineer according to the terms included in the Special Provision and General Notes herein. The quantities included are nominal and will be adjusted by the Engineer as required to meet the needs of the DCDOT. Any adjustments to quantities performed under LOR terms will be paid at pay item unit prices.

BIDDING DETAILS

This contract is subject to *shared services* clause. If the contractor agrees to provide *shared services* by agreeing to the attached *special provision*, the shared services pricing offered to all participating municipalities will be pay item unit price pricing provided that the contract is approved by the municipality prior to June 1, 2023.

This contract includes Added Alternate Bidding subject to the Special Provision included herein.

SPECIAL PROVISIONS
2023 PAVEMENT MARKING MAINTENANCE
SEC. 23-PVMKG-11-GM

BIDDING REQUIREMENTS AND CONDITIONS FOR CONTRACT PROPOSALS

(Illinois Department of Transportation Bureau of Local Roads and Streets Special Provision for BIDDING REQUIREMENTS AND CONDITIONS FOR CONTRACT PROPOSALS LRS Check Sheet #6)

Add the following to the section **Prequalification of Bidders**: “Prequalification is required. The Certificate of Eligibility shall be accompanied by a Request for Authorization to Bid form completed by the prospective bidder. The Certificate of Eligibility and Request for Authorization to Bid shall be submitted at least one business day prior to the public opening of proposals. Authorization to bid will be issued by the DuPage County Division of Transportation to prospective bidders who are qualified to perform the work, as evidenced by the Certificate of Eligibility.”

Revise the first sentence of the section **Preparation of the Proposal** to read: "Bidders shall submit their proposals on the form furnished by the Awarding Authority or on a form approved by the Awarding Authority prior to submittal of the Proposal."

Add the following to the section **Preparation of the Proposal**: "Unit prices shall only be accepted rounded to the nearest one-hundredth (0.01) of a dollar."

Add the following to the section **Preparation of the Proposal**: “The low bidder shall complete and submit the IRS W-9 form included in this proposal within 48 hours of being notified as the low bidder. The form shall be emailed to Department at DOTBidInfo@dupageco.org. All bidders may either submit the W-9 form with their bid proposal or wait to be notified that they are the low bidder.

Add the following to the section **Public Opening of Proposals**: “Proposals will only be accepted by bidders who have been issued an authorization to bid by the DuPage County Division of Transportation. Proposals submitted without authorization to bid will be returned unopened.”

Add the following to after the first sentence of the section **Consideration of Proposals**: “If the Proposal includes quantities and unit prices for multiple agencies, then the summation to be compared shall include all items and not just the items for a single agency.”

ADDED ALTERNATIVE BIDDING

Added Alternative Bidding: The DCDOT desires to maximize the available budget for this maintenance project. To accomplish this, project locations and quantities have been divided into a Base Bid (minimum project) and Added Alternatives A, B, and C. The Added Alternatives are prioritized from A to C with A being the highest priority.

A Contract Award Limit of \$500,000 has been designated for the 2023 Pavement Marking Maintenance project. As the Base Bid is the minimum project to be awarded, DCDOT will not award any contracts with a base bid greater than the Contract Award Limit.

For this maintenance project, the Contractor shall submit the same unit price for identical pay items, i.e. pay items with the same pay code. For example if the Contractor submits a unit price of \$1.25 per gallon for PROTECTIVE COAT for the Base Bid, he/she shall use the same unit price of \$1.25 per gallon for PROTECTIVE COAT in each of the Added Alternatives. Bid proposals submitted with different unit prices will be rejected.

SPECIAL PROVISIONS
2023 PAVEMNT MARKING MAINTENANCE
SEC. 23-PVMKG-11-GM

The Contractor shall submit unit prices / bids for all pay items included in the Base Bid and all Added Alternatives. Incomplete bids will be considered not responsive and will not be read.

The final bid tabulation will evaluate all bids based on the base bid and the alternatives to be included in the project. Alternatives not included in the project will not be included in the bid tabulation.

ADD ALTERNATIVE BIDDING – LOW BIDDER DETERMINATION EXAMPLES

Effective: April 1, 2011

For this project the low bidder will be determined using the process shown in the following examples:

Example 1: In this example the Contracting Authority desires to maximize the \$2,000,000 that it has available for the project. The project location and/or quantities have been divided into a Base Bid, and Added Alternatives A, B, and C. A Contract Award Limit of **\$2,000,000** has been designated.

The following bids were received:

Bidder	Base Bid	Bid on Added Alternative A	Bid on Added Alternative B	Bid on Added Alternative C
Contractor 1	\$1,500,000	\$325,000	\$150,000	\$300,000
Contractor 2	\$1,600,000	\$250,000	\$50,000	\$300,000
Contractor 3	\$1,600,000	\$100,000	\$200,000	\$200,000
Contractor 4	\$1,800,000	\$150,000	\$150,000	\$50,000

The first basis for award is the bidder submitting a bid with the most Added Alternatives (in order of priority) not exceeding the Contract Award Limit (\$2,000,000). In the example above, Contractors 1, 2 & 3 submitted bids that included the Base Bid and Added Alternatives A and B which do not exceed \$2,000,000. Contractor 4 will not be considered further because he/she submitted a bid in which the Base Bid and only Added Alternative A is less than \$2,000,000 (i.e. Contractor 4 submitted a bid with fewer options not exceeding the Contract Award Limit).

The next basis for award is the lowest bid submitted (not exceeding the Contract Award Limit) with the Base Bid and the same Added Alternative(s). In this example the Contractor's combined bids for the Base Bid and Added Alternatives A and B are:

Bidder	Combined Bid	Contractor 2's bid of \$1,900,000 is the low bid
Contractor 1	\$1,975,000	
Contractor 2	\$1,900,000	
Contractor 3	\$2,000,000	

In this example above it makes no difference that:

- Contractor 1 is the low bidder on the Base Bid only – because Added Alternatives A & B can be added to 1 or more of the Contractor's bids and the resulting combined bid does not exceed the Contract Award Limit they must be included.

SPECIAL PROVISIONS
2023 PAVEMNT MARKING MAINTENANCE
SEC. 23-PVMKG-11-GM

- Contractor 3 is the low bidder on the Base Bid and Added Alternative A – because Added Alternative B can also be added to 1 or more of the Contractor’s bids and the resulting combined bid does not exceed the Contract Award Limit it must be included.
- Contractor 4 is the low bidder on the Base Bid plus all Added Alternatives – because Contractor 4’s total bid for the Base Bid and all the Added Alternatives exceeds the Contract Award Limit it cannot be considered.

Example 2: In this example the Contracting Authority desires to maximize the \$200,000 that it has available for a maintenance project. The project location(s) and/or quantities have been divided into a Base Bid, and Added Alternatives A, B, and C. A Contract Award Limit of **\$200,000** has been designated.

The following bids were received:

Bidder	Base Bid	Bid on Added Alternative A	Bid on Added Alternative B	Bid on Added Alternative C
Contractor 1	\$165,000	\$50,000	\$15,000	\$15,000
Contractor 2	\$160,000	\$55,000	\$25,000	\$15,000
Contractor 3	\$170,000	\$35,000	\$20,000	\$15,000
Contractor 4	\$180,000	\$30,000	\$15,000	\$15,000

Like the previous example the first basis for award is the bidder submitting a bid with the most Added Alternatives (in order of priority) not exceeding the Contract Award Limit (\$200,000). In this example, all of the combined submittals for the Base Bid plus Added Alternative A are more than \$200,000. Therefore, Added Alternative A is ignored and will not be included in the contract. The bid comparison shifts to the sum of the Base Bid and Added Alternative B for which all of the Contractors submitted a bid that is less than the \$200,000 limit. The comparison continues by adding in Added Alternative C. Contractors 1 & 2 submitted bids for the Base Bid and Added Alternatives B and C which do not exceed \$200,000.

The next basis for award is the lowest bid submitted (not exceeding the Contract Award Limit) with the Base Bid and the same Added Alternative(s). In this example the Contractor’s combined bids for the Base Bid and Added Alternatives B and C are:

Bidder	Combined Bid	Contractor 1’s bid of \$195,000 is the low bid
Contractor 1	\$195,000	
Contractor 2	\$200,000	

SECTION 107 LEGAL REGULATIONS AND RESPONSIBILITY TO PUBLIC

Article 107.20 Protection and Restoration of Property. Add the following after the first paragraph of this Article:

“The Contractor shall maintain conveyance of all flows during construction of this project. When existing drainage facilities are disturbed, the Contractor shall provide and maintain temporary inlets, outlets, and connections for all private and public drains, sewers, culverts, and other drainage facilities. The Contractor shall provide facilities to take in all storm water which will be received by these drains and sewers, and discharge the same. The Contractor shall provide and maintain a pumping plant, if necessary, and a temporary outlet and be prepared at all time to dispose of water received from these temporary connections until such time that the permanent drainage facilities are in service.”

SPECIAL PROVISIONS
2023 PAVEMNT MARKING MAINTENANCE
SEC. 23-PVMKG-11-GM

Revise the last paragraph of this Article to read:

“The cost of all materials and equipment required and all labor necessary to comply with the above Provisions will not be paid for separately, but shall be considered as included in the unit bid prices of the contract, and no additional compensation will be allowed.”

Article 107.26 Indemnification. In addition to the requirements of this Article, for any activity occurring on an easement or any other property not owned by the Department, the indemnification shall also be extended to the property owners and any tenants thereon.

Article 107.27 Insurance. In addition to the requirements of this Article, the policies of insurance for Commercial (Comprehensive) General Liability and Commercial (Comprehensive) Automobile Liability shall include an additional insured endorsement naming the County of DuPage, its officers and employees as additional insureds. The endorsements shall be on forms acceptable to the County of DuPage. This additional insured is to be on a primary and non-contributory basis and include a Waiver of Subrogation endorsement.

Employer’s Liability insurance shall be in an amount not less than one million (\$1,000,000.00) dollars each accident/injury and one million (\$1,000,000.00) dollars each employee/disease.

Limits of Umbrella Excess Liability (over primary) shall not be less than an amount that in combination with Commercial General Liability totals \$6,000,000 of liability insurance per occurrence. The Umbrella Excess Liability Policy shall include in the “Who is Insured” pages of the policy wording such as “Any other person or organization you have agreed in a written contract to provide additional insurance” or wording to that affect. The contractor shall provide a copy of said section of the excess/umbrella liability policy upon request by the County of DuPage.

The Contractor shall require all subcontractors to maintain the same insurance coverage required of the contractor. The County of DuPage retains the right to obtain evidence of subcontractor insurance coverage at any time.

Replace the second sentence of the second paragraph (third to last paragraph) of this article with the following: “It is the duty of the Contractor to immediately notify the County of DuPage if any insurance required under this contract has been cancelled, materially changed, or renewal has been refused, and the Contractor shall immediately suspend all work in progress and take the necessary steps to purchase, maintain and provide the required insurance coverage. If a suspension of work should occur due to insurance requirements, upon verification by the County of DuPage of the required insurance coverage, the County of DuPage shall notify the Contractor that the Contractor can proceed with the work that is a part of this contract. Failure to provide and maintain the required insurance coverage could result in the immediate cancellation of this contract, and the Contractor shall accept and bear all costs that may result from the cancellation of this contract due to Contractor's failure to provide and maintain the required insurance.”

Article 107.36 Dust Control. Add the following to the second paragraph of this article:

“The Contractor will be required to have available a water truck or similar equipment to control dust. If necessary, the Contractor shall be required to control dust during non-working hours.”

SECTION 108 PROSECUTION AND PROGRESS

Article 108.03 Prosecution of the Work. Revise the first sentence of this Article to read, "The Contractor shall not begin the work to be performed under the contract without written authorization from the DuPage County Division of Transportation to proceed with the work, and shall commence work not later than 10 days after receiving the authorization to proceed.”

SPECIAL PROVISIONS
2023 PAVEMENT MARKING MAINTENANCE
SEC. 23-PVMKG-11-GM

This contract shall be subject to liquidated damages as described in Section 108 according to the completion date defined in the “COMPLETION DATE REQUIREMENT” Special Provision.

SECTION 109 MEASUREMENT AND PAYMENT

Article 109.08 Acceptance and Final Payment. Add the following to this Article: “Prior to final payment, an affidavit from the Contractor will be required.”

SECTION 671 MOBILIZATION

Article 671.02 Basis of Payment. Revise this article to read: “Basis of Payment. This work will not be paid for separately, but shall be included in the various items of work.”

SECTION 1105 PAVEMENT MARKING EQUIPMENT

Delete the last sentence of Article 1105.01(b).

CALENDAR DAY REQUIREMENTS

This specification will address the completion day requirements of the project:

PL –The Contractor is required to complete all the work described herein as prescribed locations by **Friday, August 11, 2023 at 5pm CST**. Failure to complete the work by the date stated above will result in liquidated damages per Article 108.09 of the Standard Specifications.

LOR –The Contractor is required to complete all assigned LOR by **Thursday, November 30, 2023 at 5pm CST**. Failure to complete the work by the date stated above will result in liquidated damages per Article 108.09 of the Standard Specifications.

TRAFFIC CONTROL AND PROTECTION

Description. The traffic control and protection for this project shall be performed in accordance with the project Traffic Control Plan and Section 701 of the Standard Specifications as amended by the Special Provision for Work Zone Traffic Control (Illinois Department of Transportation Check Sheet #LRS 3).

The furnishing, placing, and removal of material, or any temporary concrete barrier and impact attenuators, not shown on the plans but required in order to meet the drop off requirements, shall be included in the unit price of the associated pay items for MARKING, MARKING REMOVAL, and MARKER, of the type specified and for the applicable PL or LOR work category.

The cost of supplying, erecting, and maintaining barricades, warning lights, and signs will be included in the unit price of the associated pay items for MARKING, MARKING REMOVAL, and MARKER, of the type specified and for the applicable PL or LOR work category.

Method of Measurement. Traffic control will not be measured by location or per Standard.

SPECIAL PROVISIONS
2023 PAVEMNT MARKING MAINTENANCE
SEC. 23-PVMKG-11-GM

Basis of Payment. The cost of Traffic Control and Protection provided under the Traffic Control Plan and Section 701 WORK ZONE TRAFFIC CONTROL will not be paid for separately but will be included in the unit price of the associated pay items for MARKING, MARKING REMOVAL, and MARKER, of the type specified and for the applicable PL or LOR work category. No additional payment shall be made for traffic control and protection under this contract.

TRAFFIC CONTROL PLAN

Traffic Control shall be according to the applicable sections of the Standard Specifications, the Supplemental Specifications, the "Illinois Manual on Uniform Traffic Control Devices for Streets and Highways", any special details and Highway Standards contained in the plans, and the Special Provisions contained herein.

Special attention is called to Article 107.09 of the Standard Specifications and the following Highway Standards, Details, Quality Standard for Work Zone Traffic Control Devices, Recurring Special Provisions and Special Provisions contained herein, relating to traffic control.

The Contractor shall notify the Engineer at least 72 hours in advance of beginning work.

701101-05	Off-Road Operations, Multilane, 15' (4.5 m) to 24' (600 mm) From Pavement Edge
701106-02	Off-Road Operations, Multilane, More Than 15' (4.5 m) Away
701421-08	Lane Closure, Multilane, Day Operations Only, for Speeds > 45 MPH to 55 MPH
701422-10	Lane Closure, Multilane, for Speeds > 45 MPH to 55 MPH
701501-06	Urban Lane Closure, 2L, 2W, Undivided
701601-09	Urban Lane Closure, Multilane, 1W or 2W with Nontraversable Median
701606-10	Urban Single Lane Closure, Multilane, 2W with Mountable Median
701701-10	Urban Lane Closure, Multilane Intersection
701801-06	Sidewalk, Corner or Crosswalk Closure
701901-08	Traffic Control Devices

DETAILS:

TC-10	Traffic Control And Protection For Side Roads, Intersections, And Driveways
TC-14	Traffic Control And Protection At Turn Bays (To Remain Open To Traffic)
TC-16	Pavement Marking Letters And Symbols For Traffic Staging

SPECIAL PROVISIONS:

PUBLIC CONVENIENCE AND SAFETY
TRAFFIC CONTROL AND PROTECTION (SPECIAL)
MAINTENANCE OF ROADWAYS

SPECIAL PROVISIONS
2023 PAVEMENT MARKING MAINTENANCE
SEC. 23-PVMKG-11-GM

RECESSED REFLECTIVE PAVEMENT MARKERS

Description. This work shall consist of setting reflective pavement markers in a recessed groove in the pavement. The recessed pavement markers shall be used to supplement other pavement markings, similar to the use of Raised Reflective Pavement Markers.

Materials. The reflective pavement marker shall be listed on the Illinois Department of Transportation approved list of snowplowable raised pavement markers, or Engineer approved equivalent, and be compatible with the reflector holder. The reflector holder shall be a MarkerOne Series R100 reflector holder or Engineer approved equivalent. The epoxy used shall be as recommended by the pavement marker manufacturer.

Installation. Spacing and orientation of the pavement markers shall be as detailed in the plans or as directed by the Engineer.

A recessed groove shall be cut in the pavement 5.25" wide, 0.9" deep on a 15.5" diameter. An additional 3.5' long groove shall taper from 0" (normal pavement) to 0.3" depth (full-recessed).

The recessed area shall be cleaned free of all loose material, and dry before the placement of the pavement marker. All excess material resulting from the construction of the recessed area shall be completely removed from the surface of the roadway by means of vacuum sweeper truck. The pavement marker shall be cemented with epoxy in the center of the 0.9" deep recessed groove.

Inspection. A straight edge shall be placed across the recess to check that the top of the marker is below the pavement. Inspection and acceptance shall be according to Article 781.04 of the Standard Specifications.

Basis of Payment. This work will be paid for at the contract unit price each for RECESSED REFLECTIVE PAVEMENT MARKER.

45 MIL HOT SPRAY THERMOPLASTIC PAVEMENT MARKING

This work shall consist of furnishing and applying spray thermoplastic pavement marking lines, sizes and colors as shown on the plans. The material shall be a mixture of resins and other materials providing an essentially nonvolatile thermoplastic compound especially developed for traffic markings. Spray thermoplastic pavement markings shall be applied only by contractors "approved" or "conditionally approved" for HAND OPERATED APPLICATION ONLY or for TRUCK OR HAND APPLICATION, on the list of Approved Thermoplastic Contractors maintained by the IDOT Engineer of Operations and in effect on the date of advertisement for bids.

Ingredient Materials:

- (a) Binder. The binder shall consist of a mixture of synthetic resins, at least one of which is solid at room temperature. The total binder content of the thermoplastic compound shall be well distributed throughout the compound. The binder shall be free from all foreign objects or ingredients that would cause bleeding, staining or discoloration. The binder shall be 25 percent minimum by weight of the thermoplastic compound. The binder shall be characterized by an "IR Spectra". Future shipments of binder will be checked by an "IR Spectra" to verify that the binder has not been changed.

SPECIAL PROVISIONS
2023 PAVEMENT MARKING MAINTENANCE
SEC. 23-PVMKG-11-GM

- (b) Pigment. The pigment used for the white thermoplastic compound shall be a highgrade pure (minimum 93 percent) titanium dioxide (TiO₂). The white pigment content shall not be less than 10 percent by weight and shall be uniformly distributed throughout the thermoplastic compound.

The pigments used for the yellow thermoplastic compound shall be heat resistant, and color-fast yellows, golds and oranges, which shall produce a compound meeting the requirements of the current Federal Highway Color Tolerance Chart, PR Color No. 1. The medium chrome yellow pigment content shall be not less than 4 percent by weight and shall be uniformly distributed throughout the thermoplastic compound.

- (c) Filler: The filler to be incorporated with the resins as a binder shall be a white calcium carbonate, silica, or an approved substitute. Any filler, which is insoluble in 6N hydrochloric acid, shall be of such particle size as to pass a No. 100 (150 μm) sieve.
- (d) Glass Beads.

(1) Scope:

This specification covers glass beads to be used for reflectorizing pavement marking lines.

Type A – uncoated

Type B - moisture resistant, silicone coated

Type A shall be used as intermix beads with thermoplastic pavement marking materials. They shall be uniformly mixed throughout the material at the rate of not less than 25 percent by weight (retained on the No. 100 (150 μm) sieve) of thermoplastic compound. Type B shall be used as drop-on beads with thermoplastic pavement marking materials and shall be applied uniformly at a minimum rate of 6 pounds per 100 square feet (2.9 kilograms per 10 square meters).

(2) Properties:

The glass beads furnished under this specification shall consist essentially of transparent, water-white glass particles of a spherical shape. They shall be manufactured from a glass of a composition designed to be highly resistant to traffic wear and to the effects of weathering. The glass beads shall conform to the following requirements:

- (a) Sieve Analysis. The glass beads shall meet the following sieve requirements:

Total Percent (By Weight)	
<u>Sieve Size</u>	<u>Passing</u>
No. 20 (850 μm)	100
No. 30 (600 μm)	75 - 100
No. 50 (300 μm)	15 - 40
No. 100 (150 μm)	0 - 5
No. 200 (75 μm)	0 - 1

- (b) Imperfections. The surface of the glass beads shall be free of pits and scratches. The glass beads shall be spherical in shape and shall contain no more than 20 percent by weight of irregular shapes when tested by the standard method using a vibratile inclined glass plate as adopted by the Department.

SPECIAL PROVISIONS
2023 PAVEMENT MARKING MAINTENANCE
SEC. 23-PVMKG-11-GM

- (c) Index of Refraction. The index of refraction of the glass beads shall be not less than 1.50 when tested by the immersion method at 77 °F (25 °C).
- (d) Silica Content. The glass beads shall contain not less than 65 percent silica (SiO₂).
- (e) Chemical Stability. Glass beads which show a tendency toward decomposition, including surface etching, when exposed to paint or thermoplastic constituents will be rejected. The glass beads shall be tested by Federal Specification TT-B-1325B, Section 4.3.9 (water resistance) and evaluated for compliance with Section 3.2.9, with the following exceptions:

The size of the sample to be tested shall be 25 grams and the reflux time shall be 5 hours.

- (f) Flowing Properties. The glass beads shall flow uniformly through dispensing equipment in atmospheric humidity up to 94%.

Intermix beads shall pass the following test: One hundred grams of glass beads, spread evenly and thinly in a suitable container, shall be conditioned at 77 °F (25 °C) for 4 hours over a solution of sulfuric acid (Sp. Gr. 1.10) in a closed desiccator. After 4 hours, the glass beads shall flow readily through a clean glass analytical funnel, 60°, 75 mm diameter and 105 mm stem. Inside diameter of the stem shall be a nominal 1/4 inch (6.35 mm).

The drop-on beads shall have a silicone, moisture resistant coating and pass the following test: One hundred grams of beads are placed in a 600 ml beaker and an equivalent volume of distilled water shall be added to the beaker. The beaker will then stand for 5 minutes, at the end of which time the water shall be carefully poured off and the beads transferred to a clean dry beaker and allowed to stand for 5 minutes. The beads will then be poured slowly into a standard glass funnel (Corning 6120), 127 mm diameter, 102 mm stem length and 11 mm stem inside diameter.

The beads shall flow through the funnel stem without stoppage. Slight initial agitation to start the flow through the funnel at the beginning of the test is permissible.

- (g) Packaging. The Type B glass beads shall be delivered in approved moisture proof bags consisting of a least five-ply paper construction unless otherwise specified. Each bag shall contain 50 pounds (22.7 kg) net, and shall be legibly marked with the manufacturer, specifications and type, lot number, and the month and year the glass beads were packaged.

Thermoplastic Compound:

(a) Characteristic Requirements:

- (1) In the plastic state, the material shall not give off fumes that are toxic or otherwise injurious to persons or property. The manufacturer shall provide material safety data sheets for the product.

SPECIAL PROVISIONS
2023 PAVEMENT MARKING MAINTENANCE
SEC. 23-PVMKG-11-GM

- (2) The temperature versus viscosity characteristic of the plastic material shall remain constant and the material shall not deteriorate in any manner during reheating processes.
- (3) There shall be no obvious change in color of the material as a result of repeated heating or from batch to batch. The maximum elapsed time after application after which normal traffic will leave no impression or imprint on the new stripe shall be 30 seconds when the air and road surface temperature is approximately 70 ± 3 °F (21 ± 2 °C). After application and proper drying, the material shall show no appreciable deformation or discoloration, shall remain free from tack, and shall not lift from the pavement under normal traffic conditions within a road temperature range of -20 to 150 °F (-28.9 to 65.6 °C). The stripe shall maintain its original dimensions and placement.

Cold ductility of the material shall be such as to permit normal dimensional distortion as a result of traffic impact within the temperature range specified.

- (4) The material shall provide a stripe that has a uniform thickness throughout its cross section and has the density and character to provide a sharp edge of the line.
- (5) The thermoplastic compound after heating for 4 hours \pm 5 min. at 375 ± 3 °F (190.6 ± 2 °C) and cooled at 77 °F (25 °C) shall meet the following requirements for daylight reflectance and color, when tested, using a color spectrophotometer with 45° circumferential / 0° geometry, illuminant C, and 2° observer angle. The color instrument shall measure the visible spectrum from 380 to 720 nm with a wavelength measurement interval and spectral bandpass of 10 nm.

White: Daylight Reflectance, 75 percent minimum

*Yellow: Daylight Reflectance, 45 percent minimum

*Shall match Federal Highway Color Tolerance Chart, PR Color No. 1.

- (6) Specific Gravity - the specific gravity of the thermoplastic material shall not exceed 2.15.
- (7) Softening Point - After heating the thermoplastic material for 4 hours \pm 5 min. at 375 ± 3 °F (190.6 ± 2 °C) and testing in accordance with ASTM E28, the material shall have a minimum softening point of 180 °F (82.2 °C) as measured by the ring and ball method.
- (8) Tensile Bond Strength - After heating the thermoplastic material for 4 hours \pm 5 min. at 375 °F (190.6 °C), the tensile bond strength to unprimed, sandblasted portland cement concrete block, 0.0625 inch (1.587 mm) thick film drawn-down 375 °F (190.6 °C), tested at 75 ± 2 °F (23.9 ± 1 °C) shall exceed 180 psi (1.24 Mpa) when tested in accordance with ASTM D4796-88.
- (9) Impact Resistance - After heating the thermoplastic material for 4 hours \pm 5 min at 375 ± 3 °F (190.6 ± 2 °C) the impact resistance shall be a minimum of 50 inch pounds (0.576 kilogram meters) with no cracks or bond loss when 0.0625 inch (1.587 mm) thick film drawdown is made at 375 °F (190.6 °C) on an unprimed sandblasted Portland cement concrete block, male indenter 5/8 inch (15.875 mm), no female Die, tested at 75 ± 2 °F (23.9 ± 1 °C) when tested in accordance with ASTM D2794 minimum.
- (10) Yellowness Index - The white thermoplastic material shall not exceed a yellowness index of 12 when tested in accordance with ASTM D1925.

SPECIAL PROVISIONS
2023 PAVEMENT MARKING MAINTENANCE
SEC. 23-PVMKG-11-GM

(b) Identification

Each package of material shall be stenciled with the manufacturer's name, the type of material and IDOT specification number, the month and year the material was packaged and lot number. Lot numbers must begin with the last two digits of the year manufactured and be sequential with Lot 1. The letters and numbers used in the stencils shall be a minimum of 1/2 inch (12.7 mm) in height.

(c) Packaging

The thermoplastic material shall be packaged in suitable containers that will not adhere to the product during shipment and storage. The container of thermoplastic material shall weigh approximately 50 lbs. (22.7 kg). Each container shall designate the color, binder (alkyd or hydrocarbon), spray and user information. The label shall warn the user that the material shall be heated in the range of 350 – 400 °F (177 – 204 °C).

(d) Storage Life

The material shall meet the requirements of this specification for a period of one year. The thermoplastic must also melt uniformly with no evidence of skins or unmelted particles for this one-year period. The manufacturer shall replace any material that does not meet the above requirements.

Sampling and Testing:

- (a) Unless otherwise provided, all materials shall be sampled and tested in accordance with the latest published standard methods of the American Society for Testing and Materials, and revisions thereof, in effect on the date of invitation for bids, where such standard methods exist. In case there are no ASTM Standards which apply, applicable standard methods of the American Association of State Highway Transportation Officials, or the Federal Government, or of other recognized standardizing agencies shall be used.
- (b) The right is reserved to inspect the material either at the place of manufacture or at the destination or at both places. If inspected at the place of manufacture, the manufacturer shall furnish such facilities as may be required for collecting and forwarding samples, and shall also furnish facilities for testing the material during the process of manufacture, if required. Tests will be made by and at the expense of the Department. All material samples for acceptance tests shall be taken or witnessed by a representative of the Bureau of Materials and Physical Research. All material samples shall be submitted to the Engineer of Materials and Physical Research, 126 East Ash Street, Springfield, Illinois 62704-4766 at least 30 days in advance of the pavement marking operations. Random check samples may be taken at the job site at the discretion of the Engineer.
- (c) The Engineer will test and approve the basic ingredients.
- (d) The sample(s) shall be labeled with the lot number, date, quantity and any other pertinent information. Samples shall be submitted in the following manner:
- (1) Ingredient Materials:
- (a) Glass beads: At least three randomly selected bags or containers shall be obtained from each lot or shipment of glass beads. The content of each bag or container shall be passed through a large Riffle Sampler, thus splitting the material down until a representative 1-quart (1-liter) sample is obtained. The sample from each container shall be submitted for testing.

SPECIAL PROVISIONS
2023 PAVEMENT MARKING MAINTENANCE
SEC. 23-PVMKG-11-GM

- (b) Binder: One pint (0.5 liter).
 - (c) Pigments: One pint (0.5 liter).
 - (d) Filler: One pint (0.5 liter).
- (2) Thermoplastic:

At least three randomly selected containers shall be obtained from each lot. A 10 pound (4.5 kg) composite sample of the three containers shall be submitted for testing and acceptance. The lot size shall be approximately 44,000 pounds (20,000 kg) unless the total order is less than this amount.

Manufacturer's Responsibility:

- (a) The manufacturer shall perform tests on a minimum of one sample per 10,000 pounds (4,500 kg) of thermoplastic produced. Minimum tests required shall be a softening point determination and color. Manufacturer's test results shall be submitted along with the thermoplastic sample to the Bureau of Materials and Physical Research.
- (b) The manufacturer shall retain the test sample for a minimum period of 18 months.
- (c) The manufacturer shall furnish the Bureau of Materials and Physical Research with copies of bills of lading for all material inspected. Bills of lading shall indicate the consignee and destination, date of shipment, lot numbers, quantity, type of material, name and location of source.

Material Acceptance:

Final acceptance of a particular lot of thermoplastic will be based on the following:

- (a) Compliance of ingredient materials with the specifications.
- (b) Compliance of thermoplastic material with the specifications.
- (c) Manufacturer's test results for each lot of thermoplastic have been received.
- (d) Identification requirements are satisfactory.

Notification: The Contractor shall notify the Engineer 72 hours prior to the placement of the thermoplastic markings in order that an inspector can be present during the operation. At the time of this notification, the Contractor shall indicate the manufacturer and lot numbers of thermoplastic and glass beads that he intends to use. The Engineer will ensure that the approved lot numbers appear on the material package. Failure to comply with this provision may be cause for rejection.

Installation Requirements:

- (a) Before applying thermoplastic, the crack sealant shall be fully cured and hardened and the Contractor shall remove any dirt, glaze, grease, or any other material that would reduce the adhesion of the thermoplastic to the pavement.

SPECIAL PROVISIONS
2023 PAVEMENT MARKING MAINTENANCE
SEC. 23-PVMKG-11-GM

- (b) This thermoplastic material shall be readily renewable by placing an overlay of new material directly over old markings of the same material. Such new material shall bond itself to the old markings in such a manner that no splitting or separation takes place. The contractor shall remove all existing material that might cause premature failure of the new material.
- (c) The thermoplastic material shall be installed in a molten state by the spray method at a minimum temperature of 350 °F (177 °C) and a maximum temperature of 400 °F (204 °C). Scorching or discoloration of material shall be cause for rejection by the Engineer. The machinery shall be constructed so that all mixing and conveying parts, up to and including the spray gun maintain the material in the molten state.
- (d) Thermoplastic pavement marking materials shall not be applied by the spray method when air and pavement surface temperatures are below 50 °F (10 °C) or when the surface of the pavement contains any evidence of moisture.
- (e) Unless directed by the Engineer, lines shall not be laid directly over a longitudinal crack or joint. The edge of the center line or lane line shall be offset a minimum distance of 2 inches (50 mm) from a longitudinal crack or joint. Edge lines shall be approximately 2 inches (50 mm) from the edge of pavement. The finished center and lane lines shall be straight, with the lateral deviation of any 10 foot (3 meter) line not to exceed 1 inch (25 mm).
- (f) A primer sealer of the type recommended by the manufacturer of the thermoplastic material shall be applied on all Portland concrete pavement surfaces, and if recommended by the manufacturer, on other types of pavement surface, prior to the installation of the thermoplastic material. The primer shall be free of solvent and water prior to the thermoplastic application.
- (g) The thermoplastic material shall be applied at a thickness of not less than 0.045 inch (1.143 mm), but in no case shall it exceed a thickness of 0.050 inch (1.27 mm). Finished lines shall be within a 1/4 inch (6.35 mm) of the width specified in the plans.
- (h) The Contractor shall place the thermoplastic markings with adequate drop on glass in accordance with the above requirements, uniformly applied to assure nighttime reflectivity. It shall be the Contractor's responsibility to use compatible combination of thermoplastic material and beads to preclude the surface beads from sinking deeply into the thermoplastic.
- (i) The thickness of the markings will be measured above the pavement surface at such random points as the Engineer selects to determine conformance to these specifications. If the measurements show less than 0.045 inch (1.143 mm), the Engineer will "chip" the edges of the markings at random points and measure the thickness of the chips to determine if the overall thickness of the markings is at least 0.045 inch (1.143 mm). If the overall thickness or the thickness above the pavement surface is substantially in conformance with the thickness requirements, payment will be made at 100 percent of the contract unit prices involved. When the thickness at a given location is less than 0.045 inch (1.143 mm), additional measurements will be taken on each side of such location at such intervals as the Engineer may select to determine the extent of the deficient portion of the marking. The Contractor shall then apply additional thermoplastic material and beads to bring the thickness of the markings to at least 0.045 inch (1.143 mm).

Equipment Requirements:

- (a) The application equipment used for placing lane and edge line on County Highways shall be Truck-Mounted and meeting Article 1105.01 of the Standard Specifications and the requirements listed

SPECIAL PROVISIONS
2023 PAVEMENT MARKING MAINTENANCE
SEC. 23-PVMKG-11-GM

below. When the Truck-Mounted method is used, the application equipment shall be permanently mounted on a truck of sufficient size and stability to insure smooth, straight application. The truck shall be equipped to carry a minimum of 4,000 pounds (1800 kilograms) of molten thermoplastic.

The equipment shall have the capability of automatically placing intermittent and continuous lines. The equipment shall be so constructed as to provide the various widths of pavement marking lines specified. The mounting shall be such as to allow the spray equipment to accurately follow road irregularities and produce lines of uniform dimensions.

- (b) The equipment used to install hot applied thermoplastic material shall provide continuous uniform heating to temperatures exceeding 400 °F (204 °C), mixing and agitation of the material. Conveying parts of the equipment between the main material reservoir and the dispensing device shall prevent accumulation and clogging. All parts of the equipment, which comes in contact with the material, shall be constructed for easy accessibility and exposure for cleaning and maintenance. The equipment shall operate so that all mixing and conveying parts including the line dispensing device, maintains the material at the plastic temperature. The use of pans, aprons, or similar devices to prevent die overruns will not be permitted.
- (c) Glass beads applied to the surface of the completed marking shall be applied by an automatic bead dispenser attached to the marking machine so that the beads are dispensed closely behind the installed marking. The glass bead dispenser shall be equipped with an automatic cut-off control synchronized with the cut-off of the thermoplastic material.
- (d) A special kettle shall be provided for uniformly melting and heating the thermoplastic material. The kettle must be equipped with an automatic thermostat control device and material thermometer for positive temperature control and to prevent overheating or under-heating of the material. The heating kettle and application equipment shall meet the requirements of the National Fire Underwriters and the National Fire Protection Association.
- (e) The Contractor shall provide an accurate temperature measuring device which shall be capable of measuring the pavement temperature prior to installation of the thermoplastic and the temperature of the molten thermoplastic material immediately after it is applied.

Inspection: The 45 mil hot spray thermoplastic pavement markings will be inspected following installation, but no later than November 1, and inspected following a winter performance period that extends 180 days from November 1 in accordance with the provisions of Article 780.12 of the Standard Specification.

Method of Measurement: Lines will be measured for payment in feet. Double yellow lines will be measured as two separate lines.

Basis of Payment: This work will be paid for at the contract unit prices per foot of applied line width for HOT SPRAY THERMOPLASTIC PAVEMENT MARKING – LINE.

SPECIAL PROVISIONS
2023 PAVEMENT MARKING MAINTENANCE
SEC. 23-PVMKG-11-GM

MODIFIED URETHANE PAVEMENT MARKING – RAISED MEDIAN

Description. This work shall consist of removing existing median pavement marking and applying modified urethane pavement markings in accordance with Sections 780 and 783 of the Standard Specifications, except as modified herein, to the median ramped noses as shown in the plans or as directed by the Engineer.

Construction Requirements. The shotblast method of cleaning shall not be permitted.

Method of Measurement. This work will be measured for payment in place and the area computed in square feet based on the area of installed material. The area measured will include applications to concrete curb and gutter monolithic to the median ramped noses.

Basis of Payment. This work will be paid for at the contract unit price per square foot for MODIFIED URETHANE PAVEMENT MARKING – RAISED MEDIAN, which price shall include all necessary equipment, labor and materials required to remove the existing median pavement markings, prepare the surface and install the pavement markings

TEMPORARY PAVEMENT MARKING REMOVAL

Description: This work shall consist of removing all temporary or work zone pavement marking, painted pavement markings, or pavement marking tape type III in accordance with the applicable portions of Section 783 and 703 of the Standard Specifications and described herein. Pavement marking tape type III may be peeled off. Removal using high-pressure water spray, or “hydro-blast,” will not be allowed.

Equipment Requirements: All equipment shall be of sufficient capacity to efficiently and economically clean the roadway surface to the specified cleanliness. Equipment shall be power driven and in good operating condition. Equipment shall utilize moisture and oil traps, in working order, of sufficient capacity to remove contaminants from the water and prevent deposition of oil and other contaminants on the roadway surface.

Removal Requirements: Removal requirements shall be as follows:

a) The existing paint pavement markings or epoxy paint pavement markings shall be removed without pavement surface damage to the satisfaction of the Engineer.

b) Over cleaning to the extent of possible damage to the roadway surface shall be held to a minimum. Very small particles of tightly adhering existing markings may remain in place, if in the opinion of the Engineer, complete removal of the small particles will result in pavement surface damage.

Method of Measurement: The removal of temporary or work zone pavement marking, painted pavement markings, epoxy paint pavement markings, thermoplastic pavement marking, or pavement marking tape type III will be measured in square feet.

Basis of Payment: This work will be paid for at the contract unit price per square foot for TEMPORARY PAVEMENT MARKING REMOVAL.

**CHECK SHEET FOR RECURRING SPECIAL PROVISIONS
DUPAGE COUNTY PREVAILING
LOCAL ROADS AND STREETS SPECIAL PROVISIONS
BDE SPECIAL PROVISIONS**

Check Sheet for Recurring Special Provisions

Local Public Agency	County	Section Number
County of DuPage	DuPage	23-PVMKG-11-GM

Check this box for lettings prior to 01/01/2022.

The Following Recurring Special Provisions Indicated By An "X" Are Applicable To This Contract And Are Included By Reference:

Recurring Special Provisions

<u>Check Sheet #</u>		<u>Reference Page No.</u>
1	<input type="checkbox"/> Additional State Requirements for Federal-Aid Construction Contracts	1
2	<input type="checkbox"/> Subletting of Contracts (Federal-Aid Contracts)	4
3	<input type="checkbox"/> EEO	5
4	<input type="checkbox"/> Specific EEO Responsibilities Non Federal-Aid Contracts	15
5	<input type="checkbox"/> Required Provisions - State Contracts	20
6	<input type="checkbox"/> Asbestos Bearing Pad Removal	26
7	<input type="checkbox"/> Asbestos Waterproofing Membrane and Asbestos HMA Surface Removal	27
8	<input type="checkbox"/> Temporary Stream Crossings and In-Stream Work Pads	28
9	<input type="checkbox"/> Construction Layout Stakes	29
10	<input type="checkbox"/> Use of Geotextile Fabric for Railroad Crossing	32
11	<input type="checkbox"/> Subsealing of Concrete Pavements	34
12	<input type="checkbox"/> Hot-Mix Asphalt Surface Correction	38
13	<input type="checkbox"/> Pavement and Shoulder Resurfacing	40
14	<input type="checkbox"/> Patching with Hot-Mix Asphalt Overlay Removal	41
15	<input type="checkbox"/> Polymer Concrete	43
16	<input type="checkbox"/> PVC Pipeliner	45
17	<input type="checkbox"/> Bicycle Racks	46
18	<input type="checkbox"/> Temporary Portable Bridge Traffic Signals	48
19	<input type="checkbox"/> Nighttime Inspection of Roadway Lighting	50
20	<input type="checkbox"/> English Substitution of Metric Bolts	51
21	<input type="checkbox"/> Calcium Chloride Accelerator for Portland Cement Concrete	52
22	<input type="checkbox"/> Quality Control of Concrete Mixtures at the Plant	53
23	<input type="checkbox"/> Quality Control/Quality Assurance of Concrete Mixtures	61
24	<input type="checkbox"/> Digital Terrain Modeling for Earthwork Calculations	77
25	<input type="checkbox"/> Preventive Maintenance - Bituminous Surface Treatment (A-1)	79
26	<input type="checkbox"/> Temporary Raised Pavement Markers	85
27	<input type="checkbox"/> Restoring Bridge Approach Pavements Using High-Density Foam	86
28	<input type="checkbox"/> Portland Cement Concrete Inlay or Overlay	89
29	<input type="checkbox"/> Portland Cement Concrete Partial Depth Hot-Mix Asphalt Patching	93
30	<input type="checkbox"/> Longitudinal Joint and Crack Patching	96
31	<input type="checkbox"/> Concrete Mix Design - Department Provided	98
32	<input type="checkbox"/> Station Numbers in Pavements or Overlays	99

Local Public Agency	County	Section Number
County of DuPage	DuPage	23-PVMKG-11-GM

The Following Local Roads And Streets Recurring Special Provisions Indicated By An "X" Are Applicable To This Contract And Are Included By Reference:

Local Roads And Streets Recurring Special Provisions

<u>Check Sheet #</u>		<u>Page No.</u>
LRS 1	Reserved	101
LRS 2	<input type="checkbox"/> Furnished Excavation	102
LRS 3	<input checked="" type="checkbox"/> Work Zone Traffic Control Surveillance	103
LRS 4	<input checked="" type="checkbox"/> Flaggers in Work Zones	104
LRS 5	<input checked="" type="checkbox"/> Contract Claims	105
LRS 6	<input checked="" type="checkbox"/> Bidding Requirements and Conditions for Contract Proposals	106
LRS 7	<input type="checkbox"/> Bidding Requirements and Conditions for Material Proposals	112
LRS 8	Reserved	118
LRS 9	<input type="checkbox"/> Bituminous Surface Treatments	119
LRS 10	Reserved	123
LRS 11	<input checked="" type="checkbox"/> Employment Practices	124
LRS 12	<input checked="" type="checkbox"/> Wages of Employees on Public Works	126
LRS 13	<input checked="" type="checkbox"/> Selection of Labor	128
LRS 14	<input type="checkbox"/> Paving Brick and Concrete Paver Pavements and Sidewalks	129
LRS 15	<input checked="" type="checkbox"/> Partial Payments	132
LRS 16	<input checked="" type="checkbox"/> Protests on Local Lettings	133
LRS 17	<input checked="" type="checkbox"/> Substance Abuse Prevention Program	134
LRS 18	<input type="checkbox"/> Multigrade Cold Mix Asphalt	135
LRS 19	<input type="checkbox"/> Reflective Crack Control Treatment	136

DuPage County Prevailing Wage Rates posted on 1/18/2023

Trade Title	Rg	Type	C	Base	Foreman	Overtime				H/W	Pension	Vac	Trng	Other Ins
						M-F	Sa	Su	Hol					
ASBESTOS ABT-GEN	All	ALL		47.40	48.40	1.5	1.5	2.0	2.0	17.05	15.21	0.00	0.90	
ASBESTOS ABT-MEC	All	BLD		39.60	42.77	1.5	1.5	2.0	2.0	14.77	13.59	0.00	0.86	
BOILERMAKER	All	BLD		53.66	58.48	2.0	2.0	2.0	2.0	6.97	23.69	0.00	2.67	
BRICK MASON	All	BLD		49.81	54.79	1.5	1.5	2.0	2.0	12.10	21.56	0.00	1.10	
CARPENTER	All	ALL		52.01	54.01	1.5	1.5	2.0	2.0	11.79	24.76	1.50	0.80	
CEMENT MASON	All	ALL		49.75	51.75	2.0	1.5	2.0	2.0	17.08	20.74	0.00	1.00	
CERAMIC TILE FINISHER	All	BLD		44.18	44.18	1.5	1.5	2.0	2.0	12.25	14.77	0.00	1.00	
CERAMIC TILE LAYER	All	BLD		51.44	55.44	1.5	1.5	2.0	2.0	12.25	18.48	0.00	1.08	
COMMUNICATION TECHNICIAN	All	BLD		35.92	38.72	1.5	1.5	2.0	2.0	13.60	24.04	3.20	0.83	
ELECTRIC PWR EQMT OP	All	ALL		47.56	64.89	1.5	1.5	2.0	2.0	7.00	13.32	0.00	1.19	1.43
ELECTRIC PWR GRNDMAN	All	ALL		36.53	64.89	1.5	1.5	2.0	2.0	7.00	10.23	0.00	0.92	1.10
ELECTRIC PWR LINEMAN	All	ALL		57.17	64.89	1.5	1.5	2.0	2.0	7.00	16.01	0.00	1.43	1.72
ELECTRIC PWR TRK DRV	All	ALL		37.86	64.89	1.5	1.5	2.0	2.0	7.00	10.61	0.00	0.95	1.14
ELECTRICIAN	All	BLD		43.08	47.33	1.5	1.5	2.0	2.0	13.60	27.57	7.13	1.20	
ELEVATOR CONSTRUCTOR	All	BLD		62.47	70.28	2.0	2.0	2.0	2.0	16.03	20.21	5.00	0.65	
FENCE ERECTOR	NE	ALL		46.89	48.89	1.5	1.5	2.0	2.0	13.68	17.42	0.00	0.75	
FENCE ERECTOR	W	ALL		48.83	52.74	2.0	2.0	2.0	2.0	13.31	25.25	0.00	1.28	
GLAZIER	All	BLD		48.75	50.25	1.5	2.0	2.0	2.0	15.19	24.43	0.00	1.70	
HEAT/FROST INSULATOR	All	BLD		52.80	55.97	1.5	1.5	2.0	2.0	14.77	16.76	0.00	0.86	
IRON WORKER	E	ALL		55.81	57.81	2.0	2.0	2.0	2.0	16.05	25.31	0.00	0.49	
IRON WORKER	W	ALL		48.83	52.74	2.0	2.0	2.0	2.0	13.31	25.25	0.00	1.28	
LABORER	All	ALL		47.40	48.15	1.5	1.5	2.0	2.0	17.05	15.21	0.00	0.90	
LATHER	All	ALL		52.01	54.01	1.5	1.5	2.0	2.0	11.79	24.76	1.50	0.80	
MACHINIST	All	BLD		53.18	57.18	1.5	1.5	2.0	2.0	9.93	8.95	1.85	1.47	
MARBLE FINISHER	All	ALL		38.00	51.41	1.5	1.5	2.0	2.0	12.10	19.60	0.00	0.60	
MARBLE SETTER	All	BLD		48.96	53.86	1.5	1.5	2.0	2.0	12.10	21.03	0.00	0.78	
MATERIAL TESTER I	All	ALL		37.40		1.5	1.5	2.0	2.0	17.05	15.21	0.00	0.90	
MATERIALS TESTER II	All	ALL		42.40		1.5	1.5	2.0	2.0	17.05	15.21	0.00	0.90	
MILLWRIGHT	All	ALL		52.01	54.01	1.5	1.5	2.0	2.0	11.79	24.76	1.50	0.80	
OPERATING ENGINEER	All	BLD	1	55.10	59.10	2.0	2.0	2.0	2.0	22.15	19.30	2.00	2.55	
OPERATING ENGINEER	All	BLD	2	53.80	59.10	2.0	2.0	2.0	2.0	22.15	19.30	2.00	2.55	

OPERATING ENGINEER	All	BLD	3	51.25	59.10	2.0	2.0	2.0	2.0	22.15	19.30	2.00	2.55	
OPERATING ENGINEER	All	BLD	4	49.50	59.10	2.0	2.0	2.0	2.0	22.15	19.30	2.00	2.55	
OPERATING ENGINEER	All	BLD	5	58.85	59.10	2.0	2.0	2.0	2.0	22.15	19.30	2.00	2.55	
OPERATING ENGINEER	All	BLD	6	56.10	59.10	2.0	2.0	2.0	2.0	22.15	19.30	2.00	2.55	
OPERATING ENGINEER	All	BLD	7	58.10	59.10	2.0	2.0	2.0	2.0	22.15	19.30	2.00	2.55	
OPERATING ENGINEER	All	FLT		41.00	41.00	1.5	1.5	2.0	2.0	20.90	17.85	2.00	2.15	
OPERATING ENGINEER	All	HWY	1	53.30	57.30	1.5	1.5	2.0	2.0	22.15	19.30	2.00	2.55	
OPERATING ENGINEER	All	HWY	2	52.75	57.30	1.5	1.5	2.0	2.0	22.15	19.30	2.00	2.55	
OPERATING ENGINEER	All	HWY	3	50.70	57.30	1.5	1.5	2.0	2.0	22.15	19.30	2.00	2.55	
OPERATING ENGINEER	All	HWY	4	49.30	57.30	1.5	1.5	2.0	2.0	22.15	19.30	2.00	2.55	
OPERATING ENGINEER	All	HWY	5	48.10	57.30	1.5	1.5	2.0	2.0	22.15	19.30	2.00	2.55	
OPERATING ENGINEER	All	HWY	6	56.30	57.30	1.5	1.5	2.0	2.0	22.15	19.30	2.00	2.55	
OPERATING ENGINEER	All	HWY	7	54.30	57.30	1.5	1.5	2.0	2.0	22.15	19.30	2.00	2.55	
ORNAMENTAL IRON WORKER	E	ALL		53.32	55.82	2.0	2.0	2.0	2.0	14.23	25.00	0.00	1.75	
ORNAMENTAL IRON WORKER	W	ALL		48.83	52.74	2.0	2.0	2.0	2.0	13.31	25.25	0.00	1.28	
PAINTER	All	ALL		50.30	52.30	1.5	1.5	1.5	2.0	19.73	4.15	0.00	1.55	
PAINTER - SIGNS	All	BLD		41.55	46.67	1.5	1.5	2.0	2.0	3.04	3.90	0.00	0.00	
PILEDRIIVER	All	ALL		52.01	54.01	1.5	1.5	2.0	2.0	11.79	24.76	1.50	0.80	
PIPEFITTER	All	BLD		53.00	56.00	1.5	1.5	2.0	2.0	11.85	22.85	0.00	2.92	
PLASTERER	All	BLD		49.85	52.84	1.5	1.5	2.0	2.0	12.10	21.48	0.00	1.09	
PLUMBER	All	BLD		54.80	58.10	1.5	1.5	2.0	2.0	16.70	17.04	0.00	1.58	
ROOFER	All	BLD		48.00	53.00	1.5	1.5	2.0	2.0	11.83	15.26	0.00	0.99	
SHEETMETAL WORKER	All	BLD		53.33	56.00	1.5	1.5	2.0	2.0	11.85	19.43	0.00	1.59	2.54
SPRINKLER FITTER	All	BLD		54.55	57.30	1.5	1.5	2.0	2.0	14.20	18.70	0.00	0.75	
STEEL ERECTOR	E	ALL		55.81	57.81	2.0	2.0	2.0	2.0	16.05	25.31	0.00	0.49	
STEEL ERECTOR	W	ALL		48.83	52.74	2.0	2.0	2.0	2.0	13.31	25.25	0.00	1.28	
STONE MASON	All	BLD		49.81	54.79	1.5	1.5	2.0	2.0	12.10	21.56	0.00	1.10	
TERRAZZO FINISHER	All	BLD		45.57	45.57	1.5	1.5	2.0	2.0	12.25	17.14	0.00	1.03	
TERRAZZO MECHANIC	All	BLD		49.41	52.91	1.5	1.5	2.0	2.0	12.25	18.60	0.00	1.07	
TRAFFIC SAFETY WORKER I	All	HWY		39.30	40.90	1.5	1.5	2.0	2.0	9.65	9.10	0.00	0.10	
TRAFFIC SAFETY WORKER II	ALL	HWY		40.30	41.90	1.5	1.5	2.0	2.0	9.65	9.10	0.00	0.10	
TRUCK DRIVER	All	ALL	1	41.06	41.61	1.5	1.5	2.0	2.0	10.83	14.15	0.00	0.15	
TRUCK DRIVER	All	ALL	2	41.21	41.61	1.5	1.5	2.0	2.0	10.83	14.15	0.00	0.15	
TRUCK DRIVER	All	ALL	3	41.41	41.61	1.5	1.5	2.0	2.0	10.83	14.15	0.00	0.15	
TRUCK DRIVER	All	ALL	4	41.61	41.61	1.5	1.5	2.0	2.0	10.83	14.15	0.00	0.15	
TUCKPOINTER	All	BLD		49.53	50.53	1.5	1.5	2.0	2.0	9.04	21.06	0.00	1.07	

Legend**Rg** Region**Type** Trade Type - All,Highway,Building,Floating,Oil & Chip,Rivers**C** Class**Base** Base Wage Rate**OT M-F** Unless otherwise noted, OT pay is required for any hour greater than 8 worked each day, Mon through Fri. The number listed is the multiple of the base wage.**OT Sa** Overtime pay required for every hour worked on Saturdays**OT Su** Overtime pay required for every hour worked on Sundays**OT Hol** Overtime pay required for every hour worked on Holidays**H/W** Health/Welfare benefit**Vac** Vacation**Trng** Training**Other Ins** Employer hourly cost for any other type(s) of insurance provided for benefit of worker.

Explanations DUPAGE COUNTY

IRON WORKERS AND FENCE ERECTOR (WEST) - West of Route 53.

The following list is considered as those days for which holiday rates of wages for work performed apply: New Years Day, Memorial Day, Fourth of July, Labor Day, Thanksgiving Day, Christmas Day and Veterans Day in some classifications/counties. Generally, any of these holidays which fall on a Sunday is celebrated on the following Monday. This then makes work performed on that Monday payable at the appropriate overtime rate for holiday pay. Common practice in a given local may alter certain days of celebration. If in doubt, please check with IDOL.

EXPLANATION OF CLASSES

ASBESTOS - GENERAL - removal of asbestos material/mold and hazardous materials from any place in a building, including mechanical systems where those mechanical systems are to be removed. This includes the removal of asbestos materials/mold and hazardous materials from ductwork or pipes in a building when the building is to be demolished at the time or at some close future date.

ASBESTOS - MECHANICAL - removal of asbestos material from mechanical systems, such as pipes, ducts, and boilers, where the mechanical systems are to remain.

TRAFFIC SAFETY Worker I

Traffic Safety Worker I - work associated with the delivery, installation, pick-up and servicing of safety devices during periods of roadway construction, including such work as set-up and maintenance of barricades, barrier wall reflectors, drums, cones, delineators, signs, crash attenuators, glare screen and other such items, and the layout and application or removal of conflicting and/or temporary roadway markings utilized to control traffic in construction zones, as well as flagging for these operations.

TRAFFIC SAFETY WORKER II

Work associated with the installation and removal of permanent pavement markings and/or pavement markers including both installations performed by hand and installations performed by truck.

CERAMIC TILE FINISHER

The grouting, cleaning, and polishing of all classes of tile, whether for interior or exterior purposes, all burned, glazed or unglazed products; all composition materials, granite tiles, warning detectable tiles, cement tiles, epoxy composite materials, pavers, glass, mosaics, fiberglass, and all substitute materials, for tile made in tile-like units; all mixtures in tile like form of cement, metals, and other materials that are for and intended for use as a finished floor surface, stair treads, promenade roofs, walks, walls, ceilings, swimming pools, and all other places where tile is to form a finished interior or exterior. The mixing of all setting mortars including but not limited to thin-set mortars, epoxies, wall mud, and any other sand and cement mixtures or adhesives when used in the preparation, installation, repair, or maintenance of tile and/or similar materials. The handling and unloading of all sand, cement, lime, tile, fixtures, equipment, adhesives, or any other materials to be used in the preparation, installation, repair, or maintenance of tile and/or similar materials. Ceramic Tile Finishers shall fill all joints and voids regardless of method on all tile work, particularly and especially after installation of said tile work. Application of any and all protective coverings to all types of tile installations including, but not be limited to, all soap compounds, paper products, tapes, and all polyethylene coverings, plywood, masonite, cardboard, and any new type of products that may be used to protect tile installations, Blastrac equipment, and all floor scarifying equipment used in preparing floors to receive tile. The clean up and removal of all waste and materials. All demolition of existing tile floors and walls to be re-tiled.

COMMUNICATIONS TECHNICIAN

Low voltage installation, maintenance and removal of telecommunication facilities (voice, sound, data and video) including telephone and data inside wire, interconnect, terminal equipment, central offices, PABX, fiber optic cable and equipment, micro waves, V-SAT, bypass, CATV, WAN (wide area networks), LAN (local area networks), and ISDN (integrated system digital network), pulling of wire in raceways, but not the installation of raceways.

MARBLE FINISHER

Loading and unloading trucks, distribution of all materials (all stone, sand, etc.), stocking of floors with material, performing all rigging for heavy work, the handling of all material that may be needed for the installation of such materials, building of scaffolding, polishing if needed, patching, waxing of material if damaged, pointing up, caulking, grouting and cleaning of marble, holding water on diamond or Carborundum blade or saw for setters cutting, use of tub saw or any other saw needed for preparation of material, drilling of holes for wires that anchor material set by setters, mixing up of molding plaster for installation of material, mixing up thin set for the installation of material, mixing up of sand to cement for the installation of material and such other work as may be required in helping a Marble Setter in the handling of all material in the erection or installation of interior marble, slate, travertine, art marble, serpentine, alberene stone, blue stone, granite and other stones (meaning as to stone any foreign or domestic materials as are specified and used in building interiors and exteriors and customarily known as stone in the trade), carrara, sanionyx, vitrolite and similar opaque glass and the laying of all marble tile, terrazzo tile, slate tile and precast tile, steps, risers treads, base, or any other materials that may be used as substitutes for any of the aforementioned materials and which are used on interior and exterior which are installed in a similar manner.

MATERIAL TESTER I: Hand coring and drilling for testing of materials; field inspection of uncured concrete and asphalt.

MATERIAL TESTER II: Field inspection of welds, structural steel, fireproofing, masonry, soil, facade, reinforcing steel, formwork, cured concrete, and concrete and asphalt batch plants; adjusting proportions of bituminous mixtures.

OPERATING ENGINEER - BUILDING

Class 1. Asphalt Plant; Asphalt Spreader; Autograde; Backhoes with Caisson Attachment; Batch Plant; Benoto (requires Two Engineers); Boiler and Throttle Valve; Caisson Rigs; Central Redi-Mix Plant; Combination Back Hoe Front End-loader Machine; Compressor and Throttle Valve; Concrete Breaker (Truck Mounted); Concrete Conveyor; Concrete Conveyor (Truck Mounted); Concrete Paver Over 27E cu. ft; Concrete Paver 27E cu. ft. and Under: Concrete Placer; Concrete Placing Boom; Concrete Pump (Truck Mounted); Concrete Tower; Cranes, All; Cranes, Hammerhead; Cranes, (GCI and similar Type); Creter Crane; Spider Crane; Crusher, Stone, etc.; Derricks, All; Derricks, Traveling; Formless Curb and Gutter Machine; Grader, Elevating; Grouting Machines;

Heavy Duty Self-Propelled Transporter or Prime Mover; Highlift Shovels or Front Endloader 2-1/4 yd. and over; Hoists, Elevators, outside type rack and pinion and similar machines; Hoists, One, Two and Three Drum; Hoists, Two Tugger One Floor; Hydraulic Backhoes; Hydraulic Boom Trucks; Hydro Vac (and similar equipment); Locomotives, All; Motor Patrol; Lubrication Technician; Manipulators; Pile Drivers and Skid Rig; Post Hole Digger; Pre-Stress Machine; Pump Cretes Dual Ram; Pump Cretes: Squeeze Cretes-Screw Type Pumps; Gypsum Bulker and Pump; Raised and Blind Hole Drill; Roto Mill Grinder; Scoops - Tractor Drawn; Slip-Form Paver; Straddle Buggies; Operation of Tie Back Machine; Tournapull; Tractor with Boom and Side Boom; Trenching Machines.

Class 2. Boilers; Broom, All Power Propelled; Bulldozers; Concrete Mixer (Two Bag and Over); Conveyor, Portable; Forklift Trucks; Highlift Shovels or Front Endloaders under 2-1/4 yd.; Hoists, Automatic; Hoists, Inside Elevators; Hoists, Sewer Dragging Machine; Hoists, Tugger Single Drum; Laser Screed; Rock Drill (Self-Propelled); Rock Drill (Truck Mounted); Rollers, All; Steam Generators; Tractors, All; Tractor Drawn Vibratory Roller; Winch Trucks with "A" Frame.

Class 3. Air Compressor; Combination Small Equipment Operator; Generators; Heaters, Mechanical; Hoists, Inside Elevators (remodeling or renovation work); Hydraulic Power Units (Pile Driving, Extracting, and Drilling); Pumps, over 3" (1 to 3 not to exceed a total of 300 ft.); Low Boys; Pumps, Well Points; Welding Machines (2 through 5); Winches, 4 Small Electric Drill Winches.

Class 4. Bobcats and/or other Skid Steer Loaders; Oilers; and Brick Forklift.

Class 5. Assistant Craft Foreman.

Class 6. Gradall.

Class 7. Mechanics; Welders.

OPERATING ENGINEERS - HIGHWAY CONSTRUCTION

Class 1. Asphalt Plant; Asphalt Heater and Planer Combination; Asphalt Heater Scarfire; Asphalt Spreader; Autograder/GOMACO or other similar type machines; ABG Paver; Backhoes with Caisson Attachment; Ballast Regulator; Belt Loader; Caisson Rigs; Car Dumper; Central Redi-Mix Plant; Combination Backhoe Front Endloader Machine, (1 cu. yd. Backhoe Bucket or over or with attachments); Concrete Breaker (Truck Mounted); Concrete Conveyor; Concrete Paver over 27E cu. ft.; Concrete Placer; Concrete Tube Float; Cranes, all attachments; Cranes, Tower Cranes of all types: Creter Crane; Spider Crane; Crusher, Stone, etc.; Derricks, All; Derrick Boats; Derricks, Traveling; Dredges; Elevators, Outside type Rack & Pinion and Similar Machines; Formless Curb and Gutter Machine; Grader, Elevating; Grader, Motor Grader, Motor Patrol, Auto Patrol, Form Grader, Pull Grader, Subgrader; Guard Rail Post Driver Truck Mounted; Hoists, One, Two and Three Drum; Heavy Duty Self-Propelled Transporter or Prime Mover; Hydraulic Backhoes; Backhoes with shear attachments up to 40' of boom reach; Lubrication Technician; Manipulators; Mucking Machine; Pile Drivers and Skid Rig; Pre-Stress Machine; Pump Cretes Dual Ram; Rock Drill - Crawler or Skid Rig; Rock Drill - Truck Mounted; Rock/Track Tamper; Roto Mill Grinder; Slip-Form Paver; Snow Melters; Soil Test Drill Rig (Truck Mounted); Straddle Buggies; Hydraulic Telescoping Form (Tunnel); Operation of Tieback Machine; Tractor Drawn Belt Loader; Tractor Drawn Belt Loader (with attached pusher - two engineers); Tractor with Boom; Tractaire with Attachments; Traffic Barrier Transfer Machine; Trenching; Truck Mounted Concrete Pump with Boom; Raised or Blind Hole Drills (Tunnel Shaft); Underground Boring and/or Mining Machines 5 ft. in diameter and over tunnel, etc; Underground Boring and/or Mining Machines under 5 ft. in diameter; Wheel Excavator; Widener (APSCO).

Class 2. Batch Plant; Bituminous Mixer; Boiler and Throttle Valve; Bulldozers; Car Loader Trailing Conveyors; Combination Backhoe Front Endloader Machine (Less than 1 cu. yd. Backhoe Bucket or over or with attachments); Compressor and Throttle Valve; Compressor, Common Receiver (3); Concrete Breaker or Hydro Hammer; Concrete Grinding Machine; Concrete Mixer or Paver 7S Series to and including 27 cu. ft.; Concrete Spreader; Concrete Curing Machine, Burlap Machine, Belting Machine and Sealing Machine; Concrete Wheel Saw; Conveyor Muck Cars (Haglund or Similar Type); Drills, All; Finishing Machine - Concrete; Highlift Shovels or Front Endloader; Hoist - Sewer Dragging Machine; Hydraulic Boom Trucks (All Attachments); Hydro-Blaster; Hydro

Excavating (excluding hose work); Laser Screed; All Locomotives, Dinky; Off-Road Hauling Units (including articulating) Non Self-Loading Ejection Dump; Pump Cretes: Squeeze Cretes - Screw Type Pumps, Gypsum Bulker and Pump; Roller, Asphalt; Rotary Snow Plows; Rototiller, Seaman, etc., self-propelled; Self-Propelled Compactor; Spreader - Chip - Stone, etc.; Scraper - Single/Twin Engine/Push and Pull; Scraper - Prime Mover in Tandem (Regardless of Size); Tractors pulling attachments, Sheeps Foot, Disc, Compactor, etc.; Tug Boats.

Class 3. Boilers; Brooms, All Power Propelled; Cement Supply Tender; Compressor, Common Receiver (2); Concrete Mixer (Two Bag and Over); Conveyor, Portable; Farm-Type Tractors Used for Mowing, Seeding, etc.; Forklift Trucks; Grouting Machine; Hoists, Automatic; Hoists, All Elevators; Hoists, Tugger Single Drum; Jeep Diggers; Low Boys; Pipe Jacking Machines; Post-Hole Digger; Power Saw, Concrete Power Driven; Pug Mills; Rollers, other than Asphalt; Seed and Straw Blower; Steam Generators; Stump Machine; Winch Trucks with "A" Frame; Work Boats; Tamper-Form-Motor Driven.

Class 4. Air Compressor; Combination - Small Equipment Operator; Directional Boring Machine; Generators; Heaters, Mechanical; Hydraulic Power Unit (Pile Driving, Extracting, or Drilling); Light Plants, All (1 through 5); Pumps, over 3" (1 to 3 not to exceed a total of 300 ft.); Pumps, Well Points; Vacuum Trucks (excluding hose work); Welding Machines (2 through 5); Winches, 4 Small Electric Drill Winches.

Class 5. SkidSteer Loader (all); Brick Forklifts; Oilers.

Class 6. Field Mechanics and Field Welders

Class 7. Dowell Machine with Air Compressor; Gradall and machines of like nature.

OPERATING ENGINEER - FLOATING

Diver. Diver Wet Tender, Diver Tender, ROV Pilot, ROV Tender

TRUCK DRIVER - BUILDING, HEAVY AND HIGHWAY CONSTRUCTION

Class 1. Two or three Axle Trucks. A-frame Truck when used for transportation purposes; Air Compressors and Welding Machines, including those pulled by cars, pick-up trucks and tractors; Ambulances; Batch Gate Lockers; Batch Hopperman; Car and Truck Washers; Carry-alls; Fork Lifts and Hoisters; Helpers; Mechanics Helpers and Greasers; Oil Distributors 2-man operation; Pavement Breakers; Pole Trailer, up to 40 feet; Power Mower Tractors; Self-propelled Chip Spreader; Skipman; Slurry Trucks, 2-man operation; Slurry Truck Conveyor Operation, 2 or 3 man; Teamsters; Unskilled Dumpman; and Truck Drivers hauling warning lights, barricades, and portable toilets on the job site.

Class 2. Four axle trucks; Dump Crets and Adgetors under 7 yards; Dumpsters, Track Trucks, Euclids, Hug Bottom Dump Turnapulls or Turntrailers when pulling other than self-loading equipment or similar equipment under 16 cubic yards; Mixer Trucks under 7 yards; Ready-mix Plant Hopper Operator, and Winch Trucks, 2 Axles.

Class 3. Five axle trucks; Dump Crets and Adgetors 7 yards and over; Dumpsters, Track Trucks, Euclids, Hug Bottom Dump Turntrailers or turnapulls when pulling other than self-loading equipment or similar equipment over 16 cubic yards; Explosives and/or Fission Material Trucks; Mixer Trucks 7 yards or over; Mobile Cranes while in transit; Oil Distributors, 1-man operation; Pole Trailer, over 40 feet; Pole and Expandable Trailers hauling material over 50 feet long; Slurry trucks, 1-man operation; Winch trucks, 3 axles or more; Mechanic--Truck Welder and Truck Painter.

Class 4. Six axle trucks; Dual-purpose vehicles, such as mounted crane trucks with hoist and accessories; Foreman; Master Mechanic; Self-loading equipment like P.B. and trucks with scoops on the front.

TERRAZZO FINISHER

The handling of sand, cement, marble chips, and all other materials that may be used by the Mosaic Terrazzo Mechanic, and the

mixing, grinding, grouting, cleaning and sealing of all Marble, Mosaic, and Terrazzo work, floors, base, stairs, and wainscoting by hand or machine, and in addition, assisting and aiding Marble, Masonic, and Terrazzo Mechanics.

Other Classifications of Work:

For definitions of classifications not otherwise set out, the Department generally has on file such definitions which are available. If a task to be performed is not subject to one of the classifications of pay set out, the Department will upon being contacted state which neighboring county has such a classification and provide such rate, such rate being deemed to exist by reference in this document. If no neighboring county rate applies to the task, the Department shall undertake a special determination, such special determination being then deemed to have existed under this determination. If a project requires these, or any classification not listed, please contact IDOL at 217-782-1710 for wage rates or clarifications.

LANDSCAPING

Landscaping work falls under the existing classifications for laborer, operating engineer and truck driver. The work performed by landscape plantsman and landscape laborer is covered by the existing classification of laborer. The work performed by landscape operators (regardless of equipment used or its size) is covered by the classifications of operating engineer. The work performed by landscape truck drivers (regardless of size of truck driven) is covered by the classifications of truck driver.

MATERIAL TESTER & MATERIAL TESTER/INSPECTOR I AND II

Notwithstanding the difference in the classification title, the classification entitled "Material Tester I" involves the same job duties as the classification entitled "Material Tester/Inspector I". Likewise, the classification entitled "Material Tester II" involves the same job duties as the classification entitled "Material Tester/Inspector II".

LR 702
Page 1 of 1

State of Illinois
Department of Transportation
Bureau of Local Roads and Streets
SPECIAL PROVISION
FOR
CONSTRUCTION AND MAINTENANCE SIGNS

Effective: January 1, 2004
Revised: June 1, 2007

All references to Sections or Articles in this specification shall be construed to mean a specific Section or Article of the Standard Specifications for Road and Bridge Construction, adopted by the Department of Transportation.

701.14. Signs. Add the following paragraph to Article 701.14:

All warning signs shall have minimum dimensions of 1200 mm x 1200 mm (48" x 48") and have a black legend on a fluorescent orange reflectorized background, meeting, as a minimum, Type AP reflectivity requirements of Table 1091-2 in Article 1091.02.

COMPENSABLE DELAY COSTS (BDE)

Effective: June 2, 2017

Revised: April 1, 2019

Revise Article 107.40(b) of the Standard Specifications to read:

“(b) Compensation. Compensation will not be allowed for delays, inconveniences, or damages sustained by the Contractor from conflicts with facilities not meeting the above definition; or if a conflict with a utility in an unanticipated location does not cause a shutdown of the work or a documentable reduction in the rate of progress exceeding the limits set herein. The provisions of Article 104.03 notwithstanding, compensation for delays caused by a utility in an unanticipated location will be paid according to the provisions of this Article governing minor and major delays or reduced rate of production which are defined as follows.

- (1) Minor Delay. A minor delay occurs when the work in conflict with the utility in an unanticipated location is completely stopped for more than two hours, but not to exceed two weeks.
- (2) Major Delay. A major delay occurs when the work in conflict with the utility in an unanticipated location is completely stopped for more than two weeks.
- (3) Reduced Rate of Production Delay. A reduced rate of production delay occurs when the rate of production on the work in conflict with the utility in an unanticipated location decreases by more than 25 percent and lasts longer than seven calendar days.”

Revise Article 107.40(c) of the Standard Specifications to read:

“(c) Payment. Payment for Minor, Major, and Reduced Rate of Production Delays will be made as follows.

- (1) Minor Delay. Labor idled which cannot be used on other work will be paid for according to Article 109.04(b)(1) and (2) for the time between start of the delay and the minimum remaining hours in the work shift required by the prevailing practice in the area.

Equipment idled which cannot be used on other work, and which is authorized to standby on the project site by the Engineer, will be paid for according to Article 109.04(b)(4).

- (2) Major Delay. Labor will be the same as for a minor delay.

Equipment will be the same as for a minor delay, except Contractor-owned equipment will be limited to two weeks plus the cost of move-out to either the

Contractor's yard or another job and the cost to re-mobilize, whichever is less. Rental equipment may be paid for longer than two weeks provided the Contractor presents adequate support to the Department (including lease agreement) to show retaining equipment on the job is the most economical course to follow and in the public interest.

- (3) Reduced Rate of Production Delay. The Contractor will be compensated for the reduced productivity for labor and equipment time in excess of the 25 percent threshold for that portion of the delay in excess of seven calendar days. Determination of compensation will be in accordance with Article 104.02, except labor and material additives will not be permitted.

Payment for escalated material costs, escalated labor costs, extended project overhead, and extended traffic control will be determined according to Article 109.13."

Revise Article 108.04(b) of the Standard Specifications to read:

"(b) No working day will be charged under the following conditions.

- (1) When adverse weather prevents work on the controlling item.
- (2) When job conditions due to recent weather prevent work on the controlling item.
- (3) When conduct or lack of conduct by the Department or its consultants, representatives, officers, agents, or employees; delay by the Department in making the site available; or delay in furnishing any items required to be furnished to the Contractor by the Department prevents work on the controlling item.
- (4) When delays caused by utility or railroad adjustments prevent work on the controlling item.
- (5) When strikes, lock-outs, extraordinary delays in transportation, or inability to procure critical materials prevent work on the controlling item, as long as these delays are not due to any fault of the Contractor.
- (6) When any condition over which the Contractor has no control prevents work on the controlling item."

Revise Article 109.09(f) of the Standard Specifications to read:

"(f) Basis of Payment. After resolution of a claim in favor of the Contractor, any adjustment in time required for the work will be made according to Section 108. Any adjustment in the costs to be paid will be made for direct labor, direct materials, direct equipment, direct jobsite overhead, direct offsite overhead, and other direct costs allowed by the resolution. Adjustments in costs will not be made for interest charges, loss of anticipated profit, undocumented loss of efficiency, home office overhead and unabsorbed overhead

other than as allowed by Article 109.13, lost opportunity, preparation of claim expenses and other consequential indirect costs regardless of method of calculation.

The above Basis of Payment is an essential element of the contract and the claim cost recovery of the Contractor shall be so limited.”

Add the following to Section 109 of the Standard Specifications.

“109.13 Payment for Contract Delay. Compensation for escalated material costs, escalated labor costs, extended project overhead, and extended traffic control will be allowed when such costs result from a delay meeting the criteria in the following table.

Contract Type	Cause of Delay	Length of Delay
Working Days	Article 108.04(b)(3) or Article 108.04(b)(4)	No working days have been charged for two consecutive weeks.
Completion Date	Article 108.08(b)(1) or Article 108.08(b)(7)	The Contractor has been granted a minimum two week extension of contract time, according to Article 108.08.

Payment for each of the various costs will be according to the following.

- (a) Escalated Material and/or Labor Costs. When the delay causes work, which would have otherwise been completed, to be done after material and/or labor costs have increased, such increases will be paid. Payment for escalated material costs will be limited to the increased costs substantiated by documentation furnished by the Contractor. Payment for escalated labor costs will be limited to those items in Article 109.04(b)(1) and (2), except the 35 percent and 10 percent additives will not be permitted.
- (b) Extended Project Overhead. For the duration of the delay, payment for extended project overhead will be paid as follows.
- (1) Direct Jobsite and Offsite Overhead. Payment for documented direct jobsite overhead and documented direct offsite overhead, including onsite supervisory and administrative personnel, will be allowed according to the following table.

Original Contract Amount	Supervisory and Administrative Personnel
Up to \$5,000,000	One Project Superintendent
Over \$ 5,000,000 - up to \$25,000,000	One Project Manager, One Project Superintendent or Engineer, and One Clerk
Over \$25,000,000 - up to \$50,000,000	One Project Manager, One Project Superintendent, One Engineer, and

	One Clerk
Over \$50,000,000	One Project Manager, Two Project Superintendents, One Engineer, and One Clerk

(2) Home Office and Unabsorbed Overhead. Payment for home office and unabsorbed overhead will be calculated as 8 percent of the total delay cost.

(c) Extended Traffic Control. Traffic control required for an extended period of time due to the delay will be paid for according to Article 109.04.

When an extended traffic control adjustment is paid under this provision, an adjusted unit price as provided for in Article 701.20(a) for increase or decrease in the value of work by more than ten percent will not be paid.

Upon payment for a contract delay under this provision, the Contractor shall assign subrogation rights to the Department for the Department's efforts of recovery from any other party for monies paid by the Department as a result of any claim under this provision. The Contractor shall fully cooperate with the Department in its efforts to recover from another party any money paid to the Contractor for delay damages under this provision."

80384

CONSTRUCTION AIR QUALITY – DIESEL RETROFIT (BDE)

Effective: June 1, 2010

Revised: November 1, 2014

The reduction of emissions of particulate matter (PM) for off-road equipment shall be accomplished by installing retrofit emission control devices. The term “equipment” refers to diesel fuel powered devices rated at 50 hp and above, to be used on the jobsite in excess of seven calendar days over the course of the construction period on the jobsite (including rental equipment).

Contractor and subcontractor diesel powered off-road equipment assigned to the contract shall be retrofitted using the phased in approach shown below. Equipment that is of a model year older than the year given for that equipment’s respective horsepower range shall be retrofitted:

Effective Dates	Horsepower Range	Model Year
June 1, 2010 ^{1/}	600-749	2002
	750 and up	2006
June 1, 2011 ^{2/}	100-299	2003
	300-599	2001
	600-749	2002
	750 and up	2006
June 1, 2012 ^{2/}	50-99	2004
	100-299	2003
	300-599	2001
	600-749	2002
	750 and up	2006

1/ Effective dates apply to Contractor diesel powered off-road equipment assigned to the contract.

2/ Effective dates apply to Contractor and subcontractor diesel powered off-road equipment assigned to the contract.

The retrofit emission control devices shall achieve a minimum PM emission reduction of 50 percent and shall be:

- a) Included on the U.S. Environmental Protection Agency (USEPA) *Verified Retrofit Technology List* (<http://www.epa.gov/cleandiesel/verification/verif-list.htm>), or verified by the California Air Resources Board (CARB) (<http://www.arb.ca.gov/diesel/verdev/vt/cvt.htm>); or
- b) Retrofitted with a non-verified diesel retrofit emission control device if verified retrofit emission control devices are not available for equipment proposed to be used on the project, and if the Contractor has obtained a performance certification from the retrofit

device manufacturer that the emission control device provides a minimum PM emission reduction of 50 percent.

Note: Large cranes (Crawler mounted cranes) which are responsible for critical lift operations are exempt from installing retrofit emission control devices if such devices adversely affect equipment operation.

Diesel powered off-road equipment with engine ratings of 50 hp and above, which are unable to be retrofitted with verified emission control devices or if performance certifications are not available which will achieve a minimum 50 percent PM reduction, may be granted a waiver by the Department if documentation is provided showing good faith efforts were made by the Contractor to retrofit the equipment.

Construction shall not proceed until the Contractor submits a certified list of the diesel powered off-road equipment that will be used, and as necessary, retrofitted with emission control devices. The list(s) shall include (1) the equipment number, type, make, Contractor/rental company name; and (2) the emission control devices make, model, USEPA or CARB verification number, or performance certification from the retrofit device manufacturer. Equipment reported as fitted with emissions control devices shall be made available to the Engineer for visual inspection of the device installation, prior to being used on the jobsite.

The Contractor shall submit an updated list of retrofitted off-road construction equipment as retrofitted equipment changes or comes on to the jobsite. The addition or deletion of any diesel powered equipment shall be included on the updated list.

If any diesel powered off-road equipment is found to be in non-compliance with any portion of this special provision, the Engineer will issue the Contractor a diesel retrofit deficiency deduction.

Any costs associated with retrofitting any diesel powered off-road equipment with emission control devices shall be considered as included in the contract unit prices bid for the various items of work involved and no additional compensation will be allowed. The Contractor's compliance with this notice and any associated regulations shall not be grounds for a claim.

Diesel Retrofit Deficiency Deduction

When the Engineer determines that a diesel retrofit deficiency exists, a daily monetary deduction will be imposed for each calendar day or fraction thereof the deficiency continues to exist. The calendar day(s) will begin when the time period for correction is exceeded and end with the Engineer's written acceptance of the correction. The daily monetary deduction will be \$1,000.00 for each deficiency identified.

The deficiency will be based on lack of diesel retrofit emissions control.

If a Contractor accumulates three diesel retrofit deficiency deductions for the same piece of equipment in a contract period, the Contractor will be shutdown until the deficiency is corrected.

Such a shutdown will not be grounds for any extension of the contract time, waiver of penalties, or be grounds for any claim.

80261

SUBCONTRACTOR AND DBE PAYMENT REPORTING (BDE)

Effective: April 2, 2018

Add the following to Section 109 of the Standard Specifications.

“109.14 Subcontractor and Disadvantaged Business Enterprise Payment Reporting.
The Contractor shall report all payments made to the following parties:

- (a) first tier subcontractors;
- (b) lower tier subcontractors affecting disadvantaged business enterprise (DBE) goal credit;
- (c) material suppliers or trucking firms that are part of the Contractor’s submitted DBE utilization plan.

The report shall be made through the Department’s on-line subcontractor payment reporting system within 21 days of making the payment.”

80397

SUBCONTRACTOR MOBILIZATION PAYMENTS (BDE)

Effective: November 2, 2017

Revised: April 1, 2019

Replace the second paragraph of Article 109.12 of the Standard Specifications with the following:

“This mobilization payment shall be made at least seven days prior to the subcontractor starting work. The amount paid shall be at the following percentage of the amount of the subcontract reported on form BC 260A submitted for the approval of the subcontractor’s work.

Value of Subcontract Reported on Form BC 260A	Mobilization Percentage
Less than \$10,000	25%
\$10,000 to less than \$20,000	20%
\$20,000 to less than \$40,000	18%
\$40,000 to less than \$60,000	16%
\$60,000 to less than \$80,000	14%
\$80,000 to less than \$100,000	12%
\$100,000 to less than \$250,000	10%
\$250,000 to less than \$500,000	9%
\$500,000 to \$750,000	8%
Over \$750,000	7%”

80391

WORK ZONE TRAFFIC CONTROL DEVICES (BDE)

Effective: March 2, 2020

Add the following to Article 701.03 of the Standard Specifications:

“(q) Temporary Sign Supports 1106.02”

Revise the third paragraph of Article 701.14 of the Standard Specifications to read:

“For temporary sign supports, the Contractor shall provide a FHWA eligibility letter for each device used on the contract. The letter shall provide information for the set-up and use of the device as well as a detailed drawing of the device. The signs shall be supported within 20 degrees of vertical. Weights used to stabilize signs shall be attached to the sign support per the manufacturer’s specifications.”

Revise the first paragraph of Article 701.15 of the Standard Specifications to read:

“**701.15 Traffic Control Devices.** For devices that must meet crashworthiness standards, the Contractor shall provide a manufacturer’s self-certification or a FHWA eligibility letter for each Category 1 device and a FHWA eligibility letter for each Category 2 and Category 3 device used on the contract. The self-certification or letter shall provide information for the set-up and use of the device as well as a detailed drawing of the device.”

Revise the first six paragraphs of Article 1106.02 of the Standard Specifications to read:

“**1106.02 Devices.** Work zone traffic control devices and combinations of devices shall meet crashworthiness standards for their respective categories. The categories are as follows.

Category 1 includes small, lightweight, channelizing and delineating devices that have been in common use for many years and are known to be crashworthy by crash testing of similar devices or years of demonstrable safe performance. These include cones, tubular markers, plastic drums, and delineators, with no attachments (e.g. lights). Category 1 devices manufactured after December 31, 2019 shall be MASH-16 compliant. Category 1 devices manufactured on or before December 31, 2019, and compliant with NCHRP 350 or MASH 2009, may be used on contracts let before December 31, 2024.

Category 2 includes devices that are not expected to produce significant vehicular velocity change but may otherwise be hazardous. These include vertical panels with lights, barricades, temporary sign supports, and Category 1 devices with attachments (e.g. drums with lights). Category 2 devices manufactured after December 31, 2019 shall be MASH-16 compliant. Category 2 devices manufactured on or before December 31, 2019, and compliant with NCHRP 350 or MASH 2009, may be used on contracts let before December 31, 2024.

Category 3 includes devices that are expected to cause significant velocity changes or other potentially harmful reactions to impacting vehicles. These include crash cushions (impact

attenuators), truck mounted attenuators, and other devices not meeting the definitions of Category 1 or 2. Category 3 devices manufactured after December 31, 2019 shall be MASH-16 compliant. Category 3 devices manufactured on or before December 31, 2019, and compliant with NCHRP 350 or MASH 2009, may be used on contracts let before December 31, 2029. Category 3 devices shall be crash tested for Test Level 3 or the test level specified.

Category 4 includes portable or trailer-mounted devices such as arrow boards, changeable message signs, temporary traffic signals, and area lighting supports. It is preferable for Category 4 devices manufactured after December 31, 2019 to be MASH-16 compliant; however, there are currently no crash tested devices in this category, so it remains exempt from the NCHRP 350 or MASH compliance requirement.

For each type of device, when no more than one MASH-16 compliant is available, an NCHRP 350 or MASH-2009 compliant device may be used, even if manufactured after December 31, 2019.”

Revise Articles 1106.02(g), 1106.02(k), and 1106.02(l) to read:

“(g) Truck Mounted/Trailer Mounted Attenuators. The attenuator shall be approved for use at Test Level 3. Test Level 2 may be used for normal posted speeds less than or equal to 45 mph.

(k) Temporary Water Filled Barrier. The water filled barrier shall be a lightweight plastic shell designed to accept water ballast and be on the Department’s qualified product list.

Shop drawings shall be furnished by the manufacturer and shall indicate the deflection of the barrier as determined by acceptance testing; the configuration of the barrier in that test; and the vehicle weight, velocity, and angle of impact of the deflection test. The Engineer shall be provided one copy of the shop drawings.

(l) Movable Traffic Barrier. The movable traffic barrier shall be on the Department’s qualified product list.

Shop drawings shall be furnished by the manufacturer and shall indicate the deflection of the barrier as determined by acceptance testing; the configuration of the barrier in that test; and the vehicle weight, velocity, and angle of impact of the deflection test. The Engineer shall be provided one copy of the shop drawings. The barrier shall be capable of being moved on and off the roadway on a daily basis.”

80427

○ **HIGHWAY STANDARD DRAWINGS**

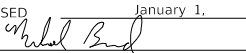
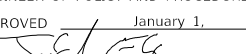

ABV	ABOVE	CU YD	CUBIC YARD	HATCH	HATCHING	PM	PAVEMENT MARKING	STD	STANDARD
A/C	ACCESS CONTROL	CULV	CULVERT	HD	HEAD	PED	PEDESTAL	SBI	STATE BOND ISSUE
AC	ACRE	C&G	CURB & GUTTER	HDW	HEADWALL	PNT	POINT	SR	STATE ROUTE
ADJ	ADJUST	D	DEGREE OF CURVE	HDUTY	HEAVY DUTY	PC	POINT OF CURVATURE	STA	STATION
AS	AERIAL SURVEYS	DC	DEPRESSED CURVE	ha	HECTARE	PI	POINT OF INTERSECTION OF HORIZONTAL CURVE	SPBGR	STEEL PLATE BEAM GUARDRAIL
AGG	AGGREGATE	DET	DETECTOR	HMA	HOT MIX ASPHALT			SS	STORM SEWER
AH	AHEAD	DIA	DIAMETER	HWY	HIGHWAY	PRC	POINT OF REVERSE CURVE	STY	STORY
APT	APARTMENT	DIST	DISTRICT	HORIZ	HORIZONTAL	PT	POINT OF TANGENCY	ST	STREET
ASPH	ASPHALT	DOM	DOMESTIC	HSE	HOUSE	POT	POINT ON TANGENT	STR	STRUCTURE
AUX	AUXILIARY	DBL	DOUBLE	IL	ILLINOIS	POLYETH	POLYETHYLENE	e	SUPERELEVATION RATE
AGS	AUXILIARY GAS VALVE (SERVICE)	DSEL	DOWNSTREAM ELEVATION	IMP	IMPROVEMENT	PCC	PORTLAND CEMENT CONCRETE	S.E. RUN.	SUPERELEVATION RUNOFF LENGTH
AVE	AVENUE	DSFL	DOWNSTREAM FLOWLINE	IN DIA	INCH DIAMETER	PP	POWER POLE OR PRINCIPAL POINT	SURF	SURFACE
AX	AXIS OF ROTATION	DR	DRAINAGE OR DRIVE	INL	INLET	PRM	PRIME	SMK	SURVEY MARKER
BK	BACK	DI	DRAINAGE INLET OR DROP INLET	INST	INSTALLATION	PE	PRIVATE ENTRANCE	T	TANGENT DISTANCE
B-B	BACK TO BACK	DRV	DRIVEWAY	IDS	INTERSECTION DESIGN STUDY	PROF	PROFILE	T.R.	TANGENT RUNOUT DISTANCE
BKPL	BACKPLATE	DCT	DUCT	INV	INVERT	PGL	PROFILE GRADELINE	TEL	TELEPHONE
B	BARN	EA	EACH	IP	IRON PIPE	PROJ	PROJECT	TB	TELEPHONE BOX
BARR	BARRICADE	EB	EASTBOUND	IR	IRON ROD	P.C.	PROPERTY CORNER	TP	TELEPHONE POLE
BL	BASELINE	EOP	EDGE OF PAVEMENT	JT	JOINT	PL	PROPERTY LINE	TEMP	TEMPORARY
BGN	BEGIN	E-CL	EDGE TO CENTERLINE	kg	KILOGRAM	PR	PROPOSED	TBM	TEMPORARY BENCH MARK
BM	BENCHMARK	E-E	EDGE TO EDGE	km	KILOMETER	R	RADIUS or RESIDENTIAL	TD	TILE DRAIN
BIND	BINDER	ELEC	ELECTRICAL	LS	LANDSCAPING	RR	RAILROAD	TBE	TO BE EXTENDED
BIT	BITUMINOUS	EL	ELEVATION	LN	LANE	RRS	RAILROAD SPIKE	TBR	TO BE REMOVED
BTM	BOTTOM	ENTR	ENTRANCE	LT	LEFT	RPS	REFERENCE POINT STAKE	TBS	TO BE SAVED
BLVD	BOULEVARD	EXC	EXCAVATION	LIDAR	LIGHT DETECTION AND RANGING	REF	REFLECTIVE	TWP	TOWNSHIP
BRK	BRICK	EX	EXISTING	LP	LIGHT POLE	RCCP	REINFORCED CONCRETE CULVERT PIPE	TR	TOWNSHIP ROAD
BBOX	BUFFALO BOX	EXPWAY	EXPRESSWAY	LGT	LIGHTING	REINF	REINFORCEMENT	TS	TRAFFIC SIGNAL
BLDG	BUILDING	E	EXTERNAL DISTANCE OF HORIZONTAL CURVE	LF	LINEAL FEET OR LINEAR FEET	REM	REMOVAL	TSCB	TRAFFIC SIGNAL CONTROL BOX
CATV	CABLE	E	OFFSET DISTANCE TO VERTICAL CURVE	L	LITER OR CURVE LENGTH	RC	REMOVE CROWN	TSC	TRAFFIC SYSTEMS CENTER
CIP	CAST IRON PIPE	F-F	FACE TO FACE	LC	LONG CHORD	REP	REPLACEMENT	TRVS	TRANSVERSE
CB	CATCH BASIN	FA	FEDERAL AID	LNG	LONGITUDINAL	REST	RESTAURANT	TRVL	TRAVEL
C-C	CENTER TO CENTER	FAI	FEDERAL AID INTERSTATE	L SUM	LUMP SUM	RESURF	RESURFACING	TRN	TURN
CL	CENTERLINE OR CLEARANCE	FAP	FEDERAL AID PRIMARY	MACH	MACHINE	RET	RETAINING	TY	TYPE
CL-E	CENTERLINE TO EDGE	FAS	FEDERAL AID SECONDARY	MB	MAIL BOX	RT	RIGHT	T-A	TYPE A
CL-F	CENTERLINE TO FACE	FAUS	FEDERAL AID URBAN SECONDARY	MH	MANHOLE	ROW	RIGHT-OF-WAY	TYP	TYPICAL
CTS	CENTERS	FP	FENCE POST	MATL	MATERIAL	RD	ROAD	UNDGND	UNDERGROUND
CERT	CERTIFIED	OPT	FIBER OPTIC	MED	MEDIAN	RDWY	ROADWAY	USGS	U.S. GEOLOGICAL SURVEY
CHSLD	CHISELED	FE	FIELD ENTRANCE	m	METER	RTE	ROUTE	USEL	UPSTREAM ELEVATION
CS	CITY STREET	FH	FIRE HYDRANT	METH	METHOD	SAN	SANITARY	USFL	UPSTREAM FLOWLINE
CP	CLAY PIPE	FL	FLOW LINE	M	MID-ORDINATE	SANS	SANITARY SEWER	UTIL	UTILITY
CLSD	CLOSED	FB	FOOT BRIDGE	mm	MILLIMETER	SEC	SECTION	VBOX	VALVE BOX
CLID	CLOSED LID	FDN	FOUNDATION	mm DIA	MILLIMETER DIAMETER	SEED	SEEDING	VV	VALVE VAULT
CT	COAT OR COURT	FR	FRAME	MIX	MIXTURE	SHAP	SHAPING	VL	VAULT
COMB	COMBINATION	F&G	FRAME & GRATE	MBH	MOBILE HOME	S	SHED	VEH	VEHICLE
C	COMMERCIAL BUILDING	FRWAY	FREEWAY	MOD	MODIFIED	SH	SHEET	VP	VENT PIPE
CE	COMMERCIAL ENTRANCE	GAL	GALLON	MFT	MOTOR FUEL TAX	SHLD	SHOULDER	VERT	VERTICAL
CONC	CONCRETE	GALV	GALVANIZED	N & BC	NAIL & BOTTLE CAP	SW	SIDEWALK OR SOUTHWEST	VC	VERTICAL CURVE
CONST	CONSTRUCT	G	GARAGE	N & C	NAIL & CAP	SIG	SIGNAL	VPC	VERTICAL POINT OF CURVATURE
CONTD	CONTINUED	GM	GAS METER	N & W	NAIL & WASHER	SOD	SODDING	VPI	VERTICAL POINT OF INTERSECTION
CONT	CONTINUOUS	GV	GAS VALVE	NC	NORMAL CROWN	SM	SOLID MEDIUM	VPT	VERTICAL POINT OF TANGENCY
COR	CORNER	GIS	GEOGRAPHICAL INFORMATION SYSTEM	NB	NORTHBOUND	SB	SOUTHBOUND	WM	WATER METER
CORR	CORRUGATED	GRAN	GRANULAR	NE	NORTHEAST	SE	SOUTHEAST	VV	WATER VALVE
CMP	CORRUGATED METAL PIPE	GR	GRATE	NW	NORTHWEST	SPL	SPECIAL	WMAIN	WATER MAIN
CNTY	COUNTY	GRVL	GRAVEL	O/S	OFFSET	SD	SPECIAL DITCH	WB	WESTBOUND
CH	COUNTY HIGHWAY	GND	GROUND	O&C	OIL AND CHIP	SQ FT	SQUARE FEET	WILDFL	WILDFLOWERS
CSE	COURSE	GUT	GUTTER	OLID	OPEN LID	m ²	SQUARE METER	W	WITH
XSECT	CROSS SECTION	GP	GUY POLE	PAT	PATTERN	mm ²	SQUARE MILLIMETER	WO	WITHOUT
m ³	CUBIC METER	GW	GUY WIRE	PVD	PAVED	SQ YD	SQUARE YARD		
mm ³	CUBIC MILLIMETER	HH	HANDHOLE	PVMT	PAVEMENT	STB	STABILIZED		

 Illinois Department of Transportation
 PASSED January 1, 2021

 ENGINEER OF POLICY AND PROCEDURES
 APPROVED January 1, 2021

 ENGINEER OF DESIGN AND ENVIRONMENT

ISSUED 1-1-97

DATE	REVISIONS
1-1-21	Updated fonts, abbreviations and symbols.
1-1-19	Added new symbols.

STANDARD SYMBOLS, ABBREVIATIONS AND PATTERNS

(Sheet 1 of 9)

STANDARD 000001-08

<u>ADJUSTMENT ITEMS</u>		<u>EX</u>	<u>PR</u>	<u>ALIGNMENT ITEMS</u>		<u>EX</u>	<u>PR</u>	<u>DRAINAGE ITEMS</u>		<u>EX</u>	<u>PR</u>
Structure To Be Adjusted			ADJ	Baseline	_____	_____		Channel or Stream Line	-----	-----	
Structure To Be Cleaned			C	Centerline	-----	-----		Culvert Line	-----	-----	
Main Structure To Be Filled			FM	Centerline Break Circle	○	○		Grading & Shaping Ditches	-----	-----	
Structure To Be Filled			F	Baseline Symbol	⊥	⊥		Drainage Boundary Line	////	////	
Structure To Be Filled Special			FSP	Centerline Symbol	⊥	⊥		Paved Ditch	-----	-----	
Structure To Be Removed			R	PI Indicator	△	△		Aggregate Ditch	-----	-----	
Structure To Be Reconstructed			REC	Point Indicator	○	○		Pipe Underdrain	-----	-----	
Structure To Be Reconstructed Special			RSP	Horizontal Curve Data (Half Size)	EX. CURVE P.I. STA= Δ= D= R= T= L= E= e= T.R.= S.E. RUN= P.C. STA= P.T. STA=	CURVE P.I. STA= Δ= D= R= T= L= E= e= T.R.= S.E. RUN= P.C. STA= P.T. STA=		Storm Sewer	-----	-----	
Frame and Grate To Be Adjusted			A	<u>BOUNDARIES ITEMS</u>		<u>EX</u>	<u>PR</u>	Flowline	⊥	⊥	
Frame and Lid To Be Adjusted			A	Dashed Property Line	-----	-----		Ditch Check	◆	◆	
Domestic Service Box To Be Adjusted			A	Solid Property/Lot Line	_____	_____		Headwall	-	∩	
Valve Vault To Be Adjusted			A	Section/Grant Line	-----	-----		Inlet	□	■	
Special Adjustment			SP	Quarter Section Line	-----	-----		Manhole	⊙	⊙	
Item To Be Abandoned			AB	Quarter/Quarter Section Line	-----	-----		Summit	↔	↔	
Item To Be Moved			M	County/Township Line	-----	-----		Roadway Ditch Flow	~→	~→	
Item To Be Relocated			REL	State Line	-----	-----		Swale	→	→	
Pavement Removal and Replacement				Chiseled Square Found	□	□		Catch Basin	○	●	
				Iron Pipe Found	○	○		Culvert End Section	◁	◁	
				Iron Pipe Set	●	●		Water Surface Indicator	▽	▽	
				Survey Marker	⊙	⊙		Riprap	▒	▒	
				Property Line Symbol	⊥	⊥		<u>HYDRAULICS ITEMS</u>		<u>EX</u>	<u>PR</u>
				Same Ownership Symbol (Half Size)	↗	↗		Overflow	↪	↪	
				Northwest Quarter Corner (Half Size)	⊙	⊙		Sheet Flow	→	→	
				Section Corner (Half Size)	⊙	⊙		Hydrant Outlet	→	→	
				Southeast Quarter Corner (Half Size)	⊙	⊙					

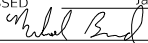
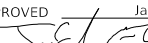
 Illinois Department of Transportation
 PASSED January 1, 2021

 ENGINEER OF POLICY AND PROCEDURES
 APPROVED January 1, 2021

 ENGINEER OF DESIGN AND ENVIRONMENT

ISSUED 1-1-97

**STANDARD SYMBOLS,
 ABBREVIATIONS
 AND PATTERNS**
 (Sheet 2 of 9)
STANDARD 000001-08

EROSION & SEDIMENT CONTROL ITEMS

EX

PR

- Cleaning & Grading Limits
- Dike
- Erosion Control Fence
- Perimeter Erosion Barrier
- Temporary Fence
- Ditch Check Temporary
- Ditch Check Permanent
- Inlet & Pipe Protection
- Sediment Basin
- Erosion Control Blanket
- Fabric Formed Concrete Revetment Mat
- Turf Reinforcement Mat
- Mulch Temporary
- Mulch Method 1
- Mulch Method 2 Stabilized
- Mulch Method 3 Hydraulic

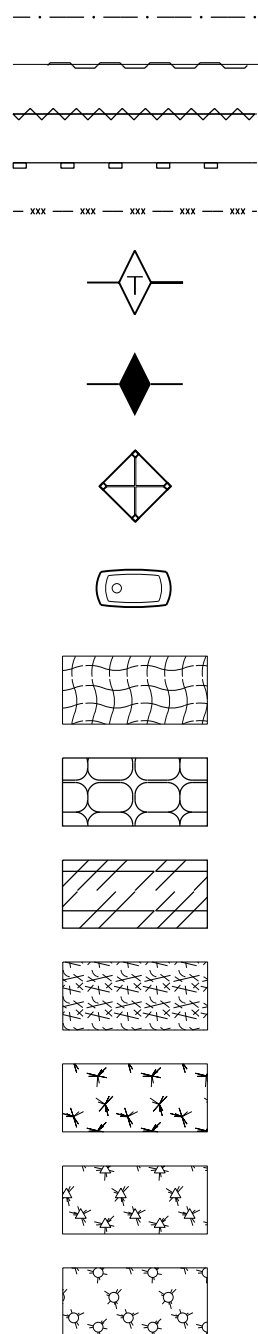

CONTOUR ITEMS

EX

PR

- Approx. Index Line
- Approx. Intermediate Line
- Index Contour
- Intermediate Contour

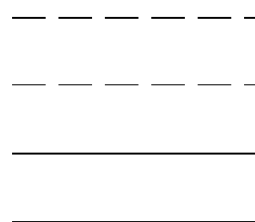

NON-HIGHWAY IMPROVEMENT ITEMS

EX

PR

- Noise Attn./Levee
- Field Line
- Fence
- Base of Levee
- Mailbox
- Multiple Mailboxes
- Pay Telephone
- Advertising Sign
- ITS* Camera
- Wind Turbine
- Cellular Tower

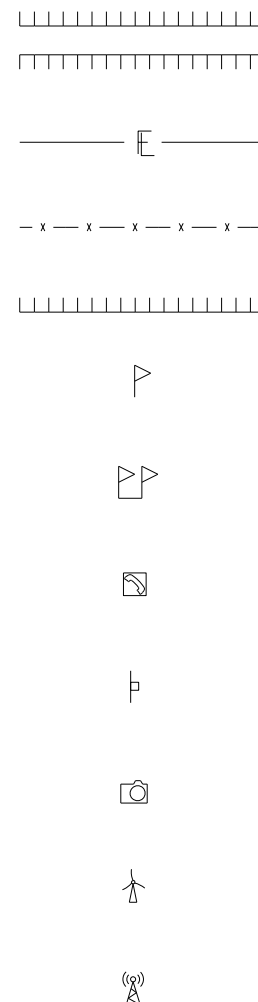

*Intelligent Transportation Systems

LANDSCAPING ITEMS

EX

PR

- Contour Mounding Line
- Fence
- Fence Post
- Shrubs
- Mowline
- Perennial Plants
- Seeding Class 2
- Seeding Class 2A
- Seeding Class 4
- Seeding Class 4 & 5 Combined

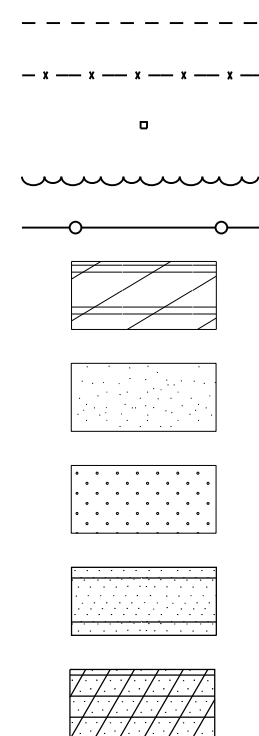

EXISTING LANDSCAPING ITEMS (contd.)

EX

PR

- Seeding Class 5
- Seeding Class 7
- Seedlings Type 1
- Seedlings Type 2
- Sodding
- Mowstake w/Sign
- Tree Trunk Protection
- Evergreen Tree
- Shade Tree

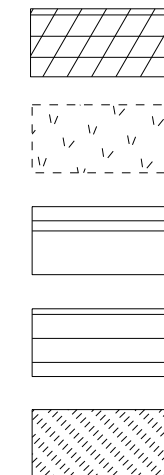

LIGHTING

EX

PR

- Duct
- Conduit
- Electrical Aerial Cable
- Electrical Buried Cable
- Controller
- Underpass Luminaire
- Power Pole

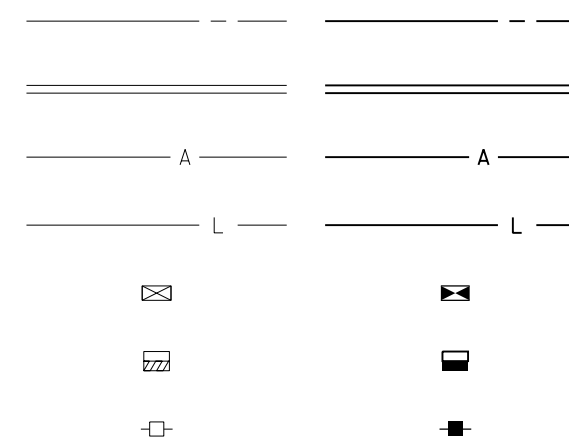

STANDARD SYMBOLS, ABBREVIATIONS AND PATTERNS

(Sheet 3 of 9)

STANDARD 000001-08

Illinois Department of Transportation

PASSED January 1, 2021
Michael Bond
 ENGINEER OF POLICY AND PROCEDURES

APPROVED January 1, 2021
Scott C. Cline
 ENGINEER OF DESIGN AND ENVIRONMENT

ISSUED 1-1-97

**LIGHTING
(contd.)**

EX

PR

Pull Point



Handhole



Heavy Duty Handhole



Junction Box



Light Unit Comb.



Electrical Ground



Traffic Flow Arrow



High Mast Pole
(Half Size)



Light Unit-1

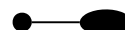

PAVEMENT (MISC.)

EX

PR

Keyed Long. Joint

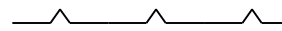

Keyed Long. Joint w/Tie Bars

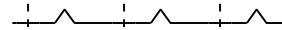

Sawed Long. Joint w/Tie Bars

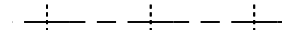

Bituminous Shoulder

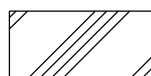

Bituminous Taper



Stabilized Driveway

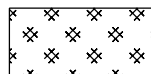

Widening



PAVEMENT MARKINGS

EX

PR

Handicap Symbol



RR Crossing

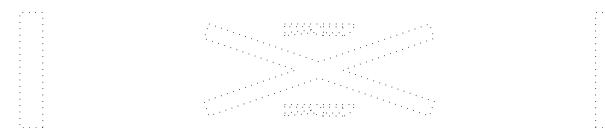

Raised Marker Amber 1 Way



Raised Marker Amber 2 Way



Raised Marker Crystal 1 Way



Two Way Turn Left



Shoulder Diag. Pattern

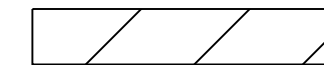

Skip-Dash White



Skip-Dash Yellow



Stop Line

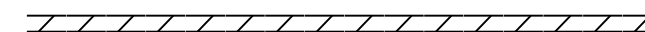

Solid Line



Double Centerline



Dotted Lines

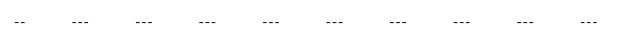

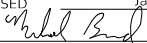
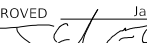
 Illinois Department of Transportation
 PASSED January 1, 2021

 ENGINEER OF POLICY AND PROCEDURES
 APPROVED January 1, 2021

 ENGINEER OF DESIGN AND ENVIRONMENT
 ISSUED 1-1-97

**STANDARD SYMBOLS,
ABBREVIATIONS
AND PATTERNS**
(Sheet 4 of 9)
STANDARD 000001-08

PAVEMENT MARKINGS
(contd.)

CL 2Ln 2Way
RRPM 12.2 m (40') o.c.

CL 2Ln 2Way
RRPM 80' (24.4 m) o.c.

CL Multilane Div.
RRPM 40' (12.2 m) o.c.

CL Multilane Div.
RRPM 80' (24.4 m) o.c.

CL Multilane Div. Dbl.
RRPM 80' (24.4 m) o.c.

CL Multilane Undiv.

Two Way Turn Left Line

Urban Combination Left

Urban Combination Right

Urban Left Turn Arrow

Urban Right Turn Arrow

Urban Left Turn Only

Urban Right Turn Only

Urban Thru Only

EX

PR

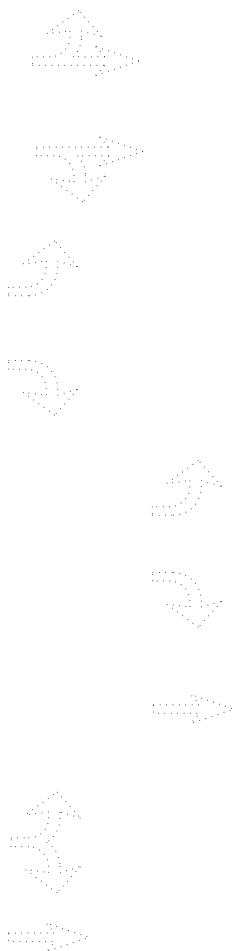
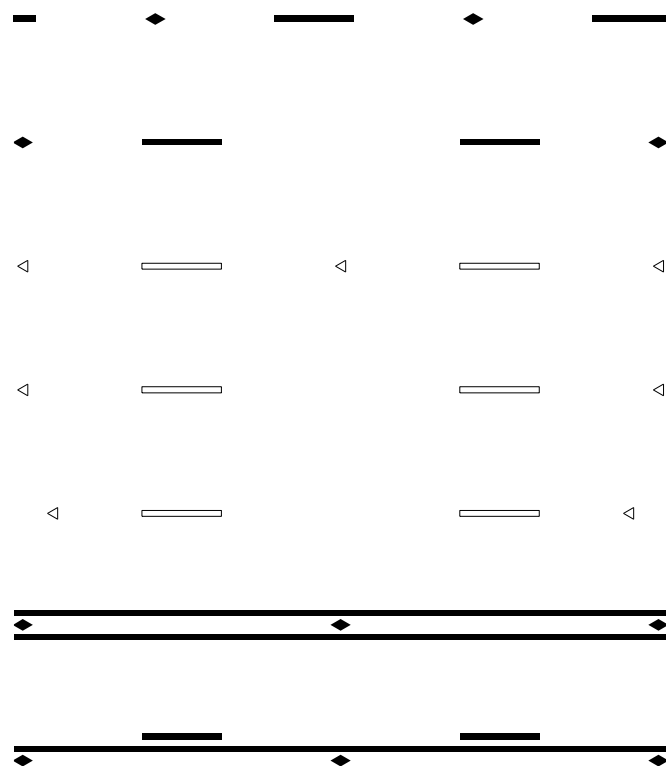

RAILROAD ITEMS

EX

PR

Abandoned Railroad

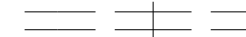

Railroad

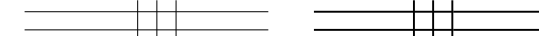

Railroad Point



Control Box



Crossing Gate



Flashing Signal



Railroad Cant. Mast Arm



Crossbuck



REMOVAL ITEMS

EX

PR

Removal Tic

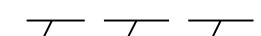

Bituminous Removal

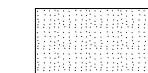

Hatch Pattern



Tree Removal Single



RIGHT OF WAY ITEMS

EX

PR

Future ROW Corner Monument



ROW Marker



ROW Line



Easement

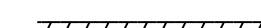
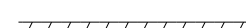

Temporary Easement

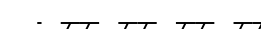

Illinois Department of Transportation

PASSED January 1, 2021
Michael Bond
ENGINEER OF POLICY AND PROCEDURES

APPROVED January 1, 2021
Scott Clark
ENGINEER OF DESIGN AND ENVIRONMENT

ISSUED 1-1-97

Urban LT & RT Turn Arrow

Urban Thru Arrow

**STANDARD SYMBOLS,
ABBREVIATIONS
AND PATTERNS**

(Sheet 5 of 9)

STANDARD 000001-08

PAVEMENT MARKINGS
(contd.)

EX

PR

Urban U-Turn



Urban Combined U-Turn



Rural Combination Left



Rural Combination Right



Rural Left Turn Arrow



Rural Right Turn Arrow



Rural Left Turn Only



ONLY ONLY ONLY



Rural Right Turn Only



Rural Thru Only

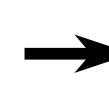
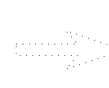

Rural Thru Arrow



Rural Lt & Rt Turn Arrow



Bike Lane Symbol

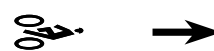

Bike Lane Text



Bike Path Shared



Bike Shared Roadway



Lane Drop Symbol



Wrong Way Arrow



Illinois Department of Transportation

PASSED Michael Bond January 1, 2021
ENGINEER OF POLICY AND PROCEDURES

APPROVED Joe E. Cline January 1, 2021
ENGINEER OF DESIGN AND ENVIRONMENT

ISSUED 1-1-97

**STANDARD SYMBOLS,
ABBREVIATIONS
AND PATTERNS**
(Sheet 6 of 9)

STANDARD 000001-08

RIGHT OF WAY ITEMS
(contd.)

	<u>EX</u>	<u>PR</u>
Access Control Line	—	— AC —
Access Control Line & ROW	— AC —	— AC —
Access Control Line & ROW with Fence	— x — AC —	— x — AC — x —
Excess ROW Line		— XS —

ROADWAY PLAN
ITEMS

	<u>EX</u>	<u>PR</u>
Cable Barrier		
Concrete Barrier		
Edge of Pavement	---	---
Bit Shoulders, Medians and C&G Line	---	---
Aggregate Shoulder	---	---
Sidewalks, Driveways	---	---
Guardrail		
Guardrail Post	□	
Traffic Sign	⊥	⊥
Corrugated Median		
Impact Attenuator		
North Arrow with District Office (Half Size)		
Match Line		STA. 45+00
Slope Limit Line	---	
Typical Cross-Section Line	---	---

ROADWAY PROFILES

	<u>EX</u>	<u>PR</u>
P.I. Indicator	△	△
Point Indicator	○	○
Earthworks Balance Point		
Begin Point		
Vert. Curve Data	VPI = ELEV = L = E =	VPI = ELEV = L = E =
Ditch Profile Left Side	-----	-----
Ditch Profile Right Side	-----	-----
Roadway Profile Line	-----	-----
Storm Sewer Profile Left Side	-----	-----
Storm Sewer Profile Right Side	-----	-----

SIGNING ITEMS

	<u>EX</u>	<u>PR</u>
Cone, Drum or Barricade		○
Barricade Type II		
Barricade Type III		TT
Barricade With Edge Line		
Flashing Light Sign		○
Panels I		
Panels II		
Direction of Traffic		
Sign Flag (Half Size)		

SIGNING ITEMS
(contd.)

	<u>EX</u>	<u>PR</u>
Reverse Left W1-4L (Half Size)		
Reverse Right W1-4R (Half Size)		
Two Way Traffic Sign W6-3 (Half Size)		
Detour Ahead W20-2(O) (Half Size)		
Left Lane Closed Ahead W20-5L(O) (Half Size)		
Right Lane Closed Ahead W20-5R(O) (Half Size)		
Road Closed Ahead W20-3(O) (Half Size)		
Road Construction Ahead W20-1(O) (Half Size)		
Single Lane Ahead (Half Size)		
Transition Left W4-2L (Half Size)		
Transition Right W4-2R (Half Size)		

Illinois Department of Transportation

PASSED January 1, 2021
Michael Bond
ENGINEER OF POLICY AND PROCEDURES

APPROVED January 1, 2021
Joe E. Cole
ENGINEER OF DESIGN AND ENVIRONMENT

ISSUED 1-1-97

**STANDARD SYMBOLS,
ABBREVIATIONS
AND PATTERNS**
(Sheet 7 of 9)

STANDARD 000001-08

SIGNING ITEMS
(contd.)

EX

PR

One Way Arrow Lrg. W1-6-(O)
(Half Size)



Two Way Arrow Large W1-7-(O)
(Half Size)



Detour M4-10L-(O)
(Half Size)



Detour M4-10R-(O)
(Half Size)



One Way Left R6-1L
(Half Size)



One Way Right R6-1R
(Half Size)



Left Turn Lane R3-I100L
(Half Size)



Keep Left R4-7AL
(Half Size)



Keep Left R4-7BL
(Half Size)



Keep Right R4-7AR
(Half Size)



Keep Right R4-7BR
(Half Size)



Stop Here On Red R10-6-AL
(Half Size)



Stop Here On Red R10-6-AR
(Half Size)



No Left Turn R3-2
(Half Size)



No Right Turn R3-1
(Half Size)



Road Closed R11-2
(Half Size)



Road Closed Thru Traffic R11-2
(Half Size)



STRUCTURES ITEMS

EX

PR

Box Culvert Barrel

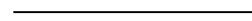

Box Culvert Headwall



Bridge Pier

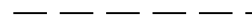

Bridge

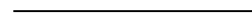

Retaining Wall



Temporary Sheet Piling



TRAFFIC SHEET ITEMS

EX

PR

Cable Number



Left Turn Green



Left Turn Yellow



Signal Backplate



Signal Section 8" (200 mm)



Signal Section 12" (300 mm)



Walk/Don't Walk Letters



Walk/Don't Walk Symbols



TRAFFIC SIGNAL ITEMS

EX

PR

Galv. Steel Conduit



Underground Cable

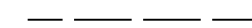
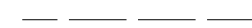

Detector Loop Line

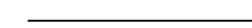

Detector Loop Large



Detector Loop Small



Detector Loop Quadrapole



**STANDARD SYMBOLS,
ABBREVIATIONS
AND PATTERNS**

(Sheet 8 of 9)

STANDARD 000001-08

Illinois Department of Transportation

PASSED January 1, 2021
Michael Bond
ENGINEER OF POLICY AND PROCEDURES

APPROVED January 1, 2021
Joe E. Cole
ENGINEER OF DESIGN AND ENVIRONMENT

ISSUED 1-1-97

TRAFFIC SIGNAL ITEMS (contd.)

EX

PR

Detector Raceway



Aluminum Mast Arm



Steel Mast Arm



Veh. Detector Magnetic



Conduit Splice



Controller



Gulfbox Junction



Wood Pole



Temp. Signal Head



Handhole



Double Handhole



Heavy Duty Handhole



Junction Box



Ped. Pushbutton Detector



Ped. Signal Head



Power Pole Service



Priority Veh. Detector



Signal Head



Signal Head w/Backplate



Signal Post



Closed Circuit TV



Video Detector System



UNDERGROUND UTILITY ITEMS

EX

PR

ABANDONED

Cable TV



Electric Cable

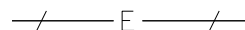
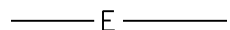

Fiber Optic



Gas Pipe

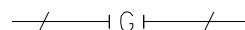

Oil Pipe

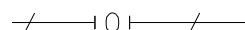
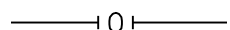
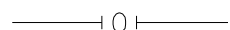

Sanitary Sewer

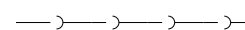
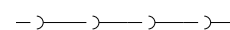

Telephone Cable

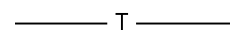

Water Pipe

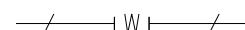
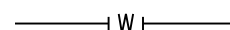
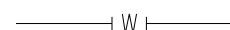

UTILITIES ITEMS

EX

PR

Controller



Double Handhole



Fire Hydrant



GuyWire or Deadman Anchor



Handhole



Heavy Duty Handhole



Junction Box



Light Pole



Manhole



Monitoring Well (Gasoline)



Pipeline Warning Sign



Power Pole



Power Pole with Light



Sanitary Sewer Cleanout



Splice Box Above Ground



Telephone Splice Box Above Ground



Telephone Pole



UTILITY ITEMS (contd.)

EX

PR

Traffic Signal



Traffic Signal Control Box



Water Meter



Water Meter Valve Box



Profile Line

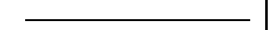

Aerial Power Line

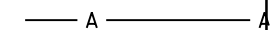

VEGETATION ITEMS

EX

PR

Deciduous Tree



Bush or Shrub



Evergreen Tree



Stump



Orchard/Nursery Line

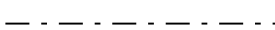

Vegetation Line

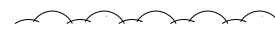

Woods & Bush Line



WATER FEATURE ITEMS

EX

PR

Stream or Drainage Ditch

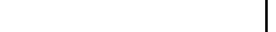
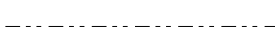

Waters Edge



Water Surface Indicator



Water Point



Disappearing Ditch



Marsh



Marsh/Swamp Boundary



Illinois Department of Transportation

PASSED January 1, 2021
Michael Bond
 ENGINEER OF POLICY AND PROCEDURES

ISSUED 1-1-97

APPROVED January 1, 2021
Joe E. Cole
 ENGINEER OF DESIGN AND ENVIRONMENT

STANDARD SYMBOLS, ABBREVIATIONS AND PATTERNS
 (Sheet 9 of 9)

STANDARD 000001-08

- ① Devices at 20' (6 m) centers in the taper.
- ② Cones at 25' (8 m) centers for the first 150' (45 m). Additional cones may be placed at 50' (15 m) centers. When drums or barricades are used, these intervals between devices may be doubled.

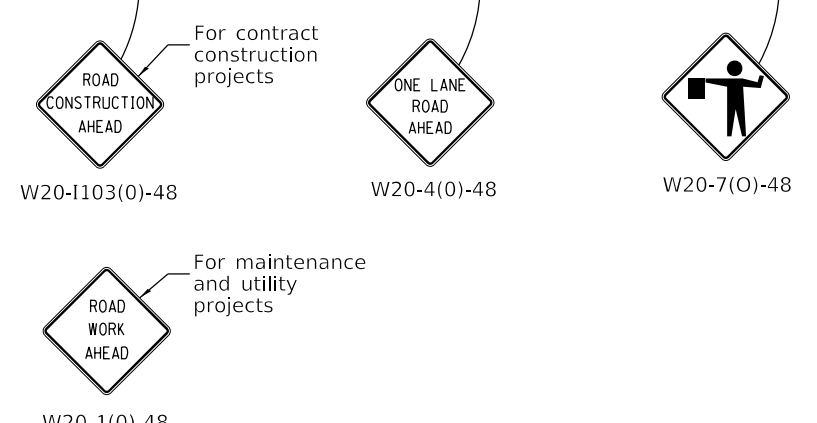
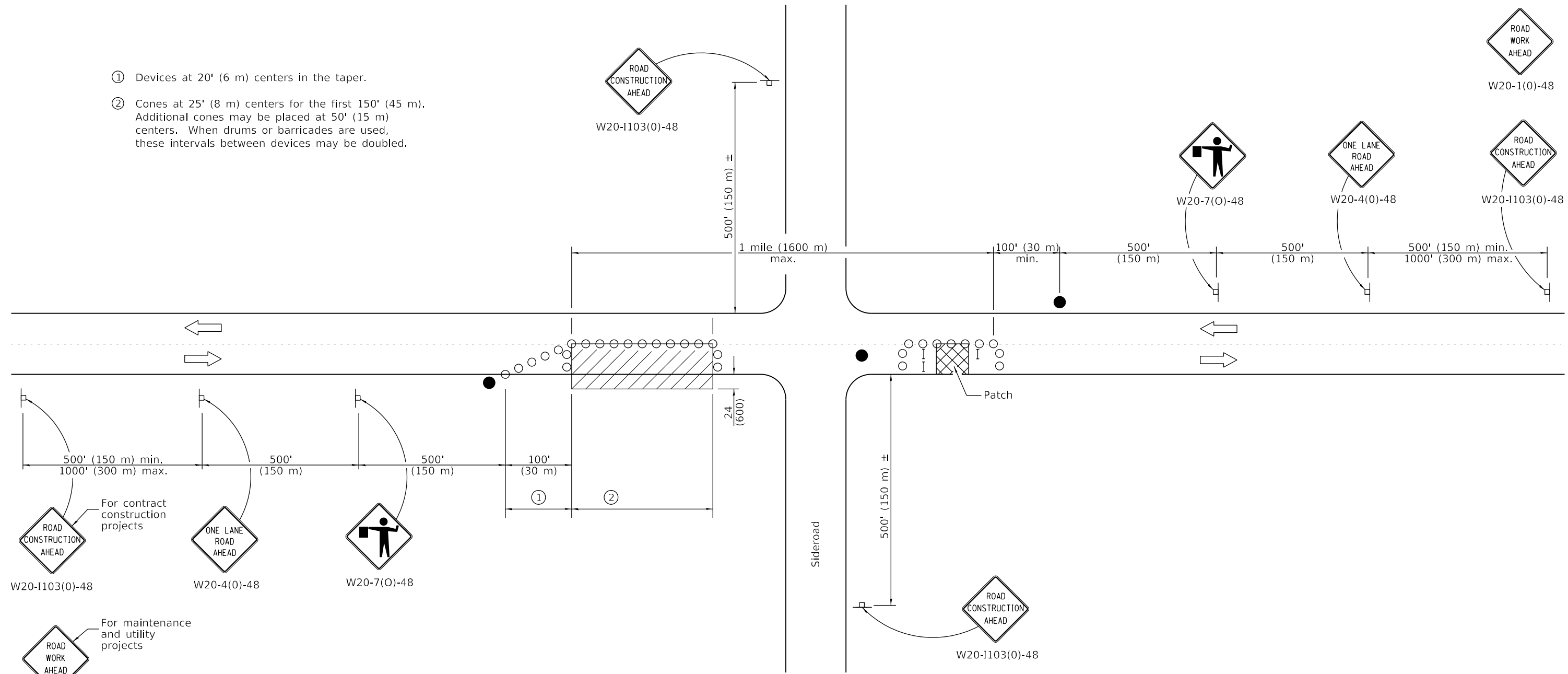

TYPICAL APPLICATIONS

- Isolated patching
- Utility operations
- Storm sewer
- Culverts
- Cable placement

SYMBOLS

- Work area
- Sign
- Barricade or drum
- Cone, drum or barricade
- Flagger with traffic control sign

GENERAL NOTES

This Standard is used where at any time, any vehicles, equipment, workers or their activities will encroach in the area between the center line and a line 24 (600) outside the edge of pavement for daylight operation.

When the distance between successive work areas exceeds 2000' (600 m), additional warning signs, flaggers, and taper shall be placed as shown.

All dimensions are in inches (millimeters) unless otherwise shown.

Illinois Department of Transportation

APPROVED January 1, 2019

 ENGINEER OF SAFETY PROG. AND ENGINEERING

APPROVED January 1, 2019

 ENGINEER OF DESIGN AND ENVIRONMENT

ISSUED 1-1-97

DATE	REVISIONS
1-1-19	Revised device spacing in taper.
1-1-11	Revised flagger sign.

**LANE CLOSURE, 2L, 2W,
DAY ONLY,
FOR SPEEDS ≥ 45 MPH**

STANDARD 701201-05

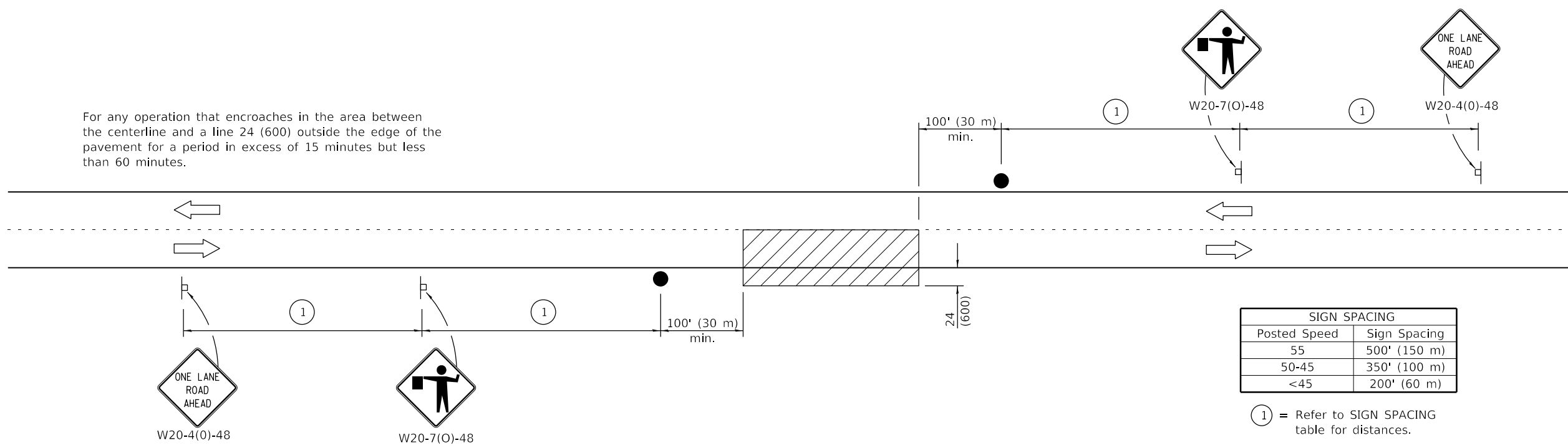
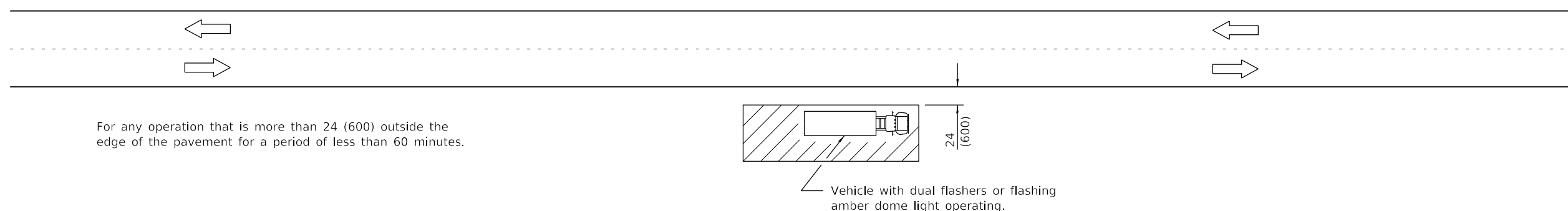
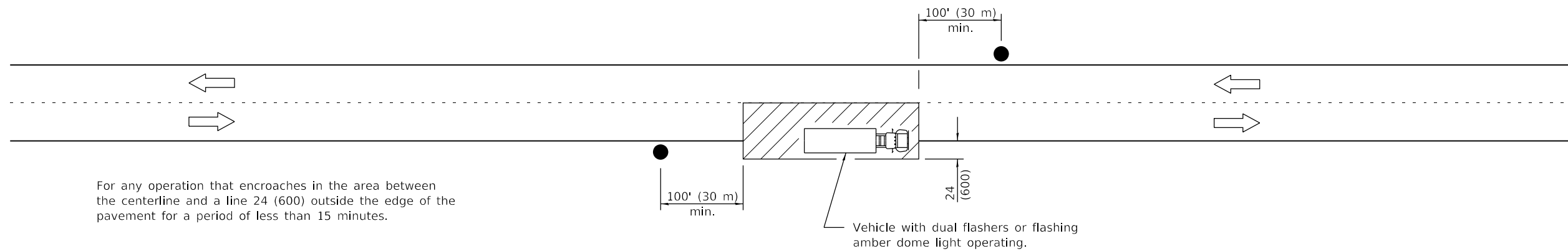

TYPICAL APPLICATIONS

- Marking patches
- Field survey
- String line
- Utility operations
- Cleaning up debris on pavement

SYMBOLS

- Work area
- Sign on portable or permanent support
- Flagger with traffic control sign

All dimensions are in inches (millimeters) unless otherwise shown.

Illinois Department of Transportation

PASSED January 1, 2011
[Signature]
 ENGINEER OF SAFETY ENGINEERING

ISSUED 1-1-97

APPROVED January 1, 2011
[Signature]
 ENGINEER OF DESIGN AND ENVIRONMENT

DATE	REVISIONS
1-1-11	Revised flagger sign.
1-1-09	Switched units to English (metric).

**LANE CLOSURE, 2L, 2W,
SHORT TIME OPERATIONS**

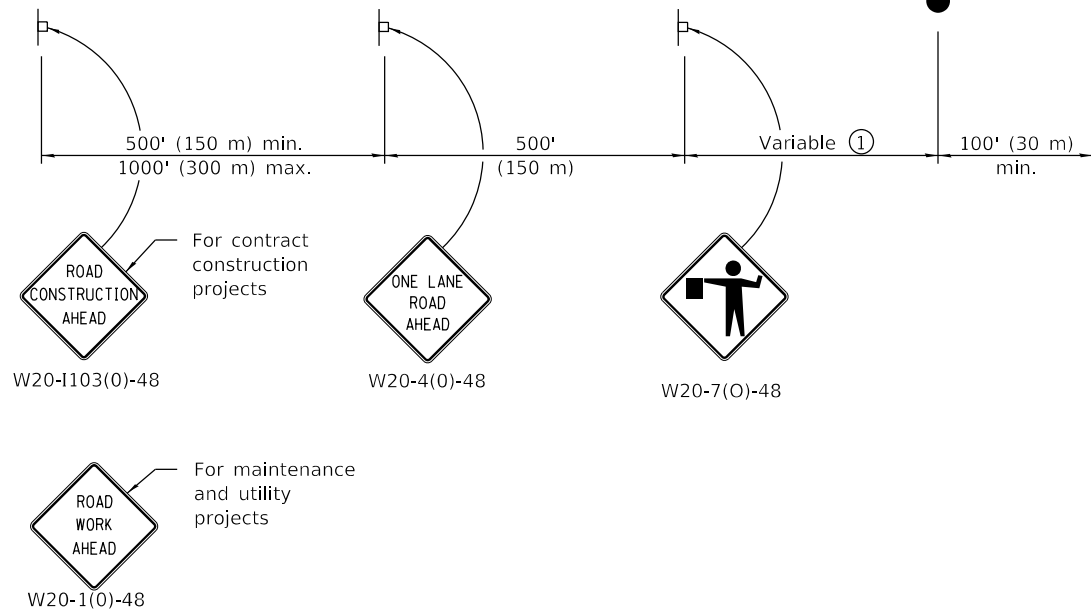
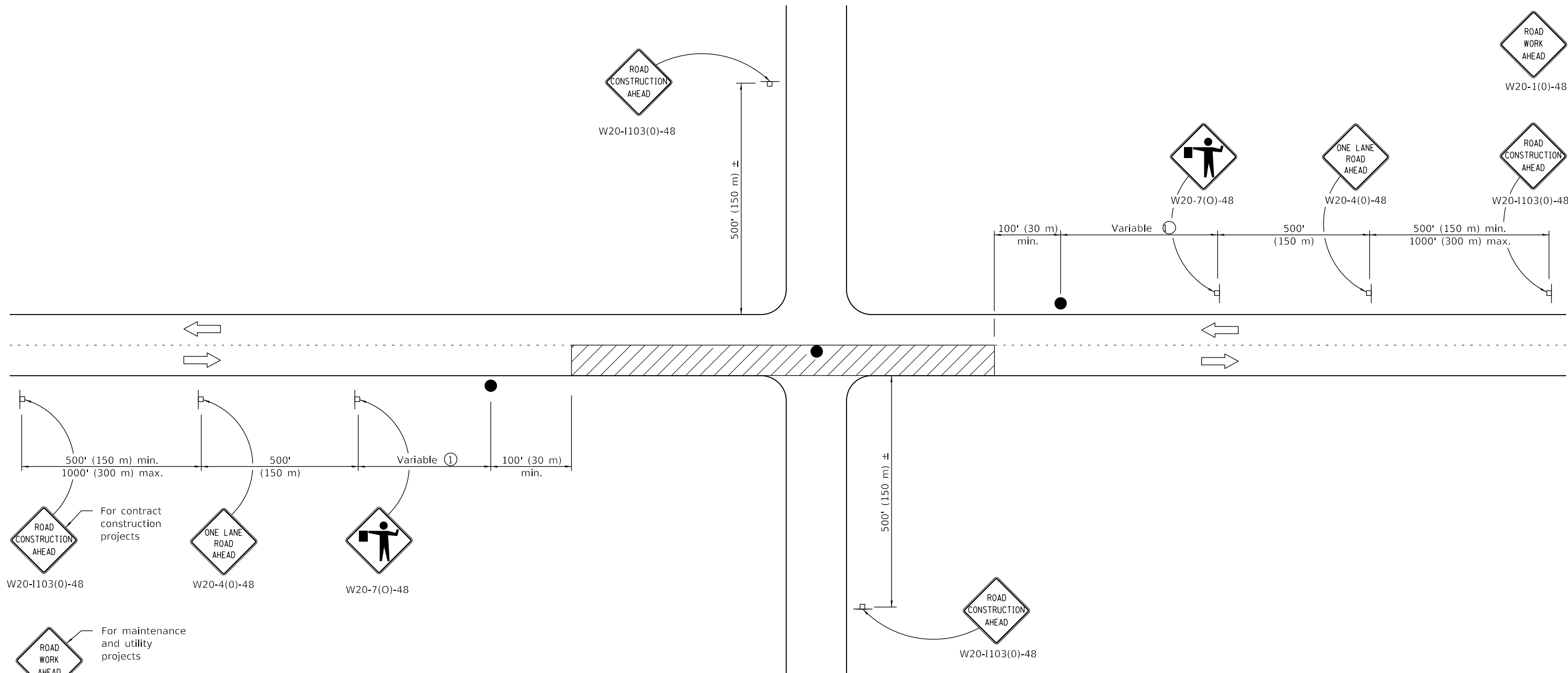

STANDARD 701301-04



TYPICAL APPLICATIONS

- Bituminous resurfacing
- Milling operations
- Utility operations
- Shoulder operations

SYMBOLS

-  Work area
-  Sign on portable or permanent support
-  Flagger with traffic control sign

① Minimum distance is 200' (60 m). Maximum distance to be determined by the Engineer but should not exceed ½ the length required for one normal working day's operation or 2 miles (3200 m), whichever is less.

GENERAL NOTES

This Standard is used where at any time, any vehicle, equipment, workers or their activities require an intermittent or continuous moving operation on the pavement where the average speed of movement is greater than ½ mph (1 km/h) and less than 4 mph (6 km/h).

When the operation does not exceed 60 minutes, traffic control may be according to Standard 701301.

All dimensions are in inches (millimeters) unless otherwise shown.

DATE	REVISIONS
1-1-18	Revised lower speed limit for operation to ½ mph.
1-1-11	Revised flagger sign.

LANE CLOSURE, 2L, 2W, SLOW MOVING OPERATIONS DAY ONLY, FOR SPEEDS ≥ 45 MPH

STANDARD 701306-04

Illinois Department of Transportation

PASSED January 1, 2018

Paul L. ...
ENGINEER OF SAFETY PROG. AND ENGINEERING

APPROVED January 1, 2018

Maureen M. ...
ENGINEER OF DESIGN AND ENVIRONMENT



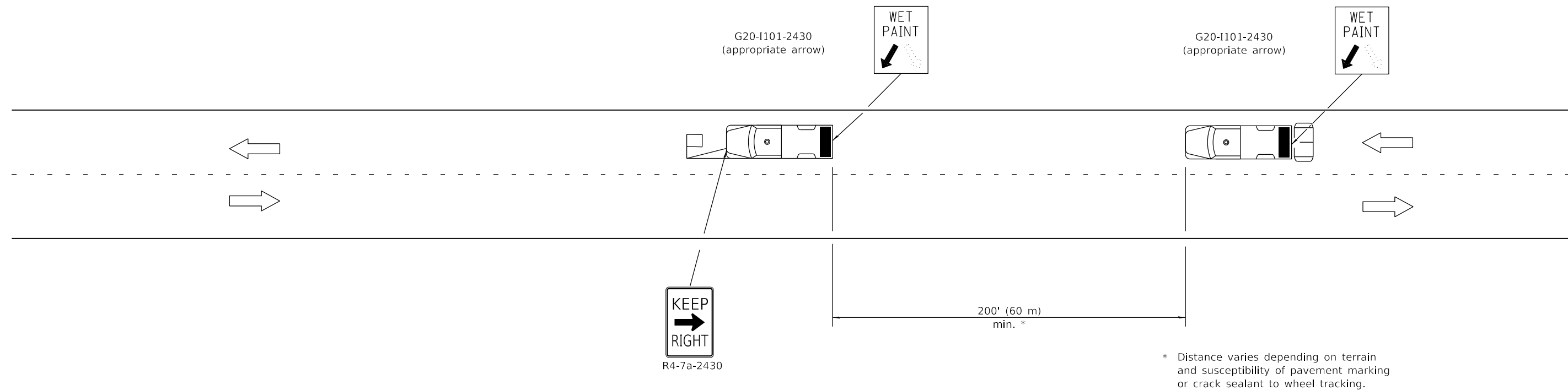

ISSUED 1-1-97



TYPICAL APPLICATIONS

- Landscaping work
- Utility work
- Pavement marking
- Weed spraying
- Roadometer measurements
- Debris cleanup
- Crack pouring

SYMBOLS

-  Arrow board (Hazard Mode only)
-  Truck with headlights, emergency flashers and flashing amber light. (visible from all directions)
-  18x18 (450x450) min. orange flag (use when guide wheel is used)
-  Truck mounted attenuator

GENERAL NOTES

This Standard is used where any vehicle, equipment, workers or their activities will require a continuous moving operation where the average speed is greater than 3 mph (5 km/h).

For shoulder operations not encroaching on the pavement, use DETAIL A, Standard 701426.

All dimensions are in inches (millimeters) unless otherwise shown.

DATE	REVISIONS
1-1-09	Switched units to English (metric). Omitted Pass With Care sign.
1-1-00	Elim. speed restrictions in Standard title.

LANE CLOSURE 2L, 2W MOVING OPERATIONS-DAY ONLY

STANDARD 701311-03

Illinois Department of Transportation

PASSED January 1, 2009

ENGINEER OF OPERATIONS

APPROVED January 1, 2009

ENGINEER OF DESIGN AND ENVIRONMENT

ISSUED 1-1-97

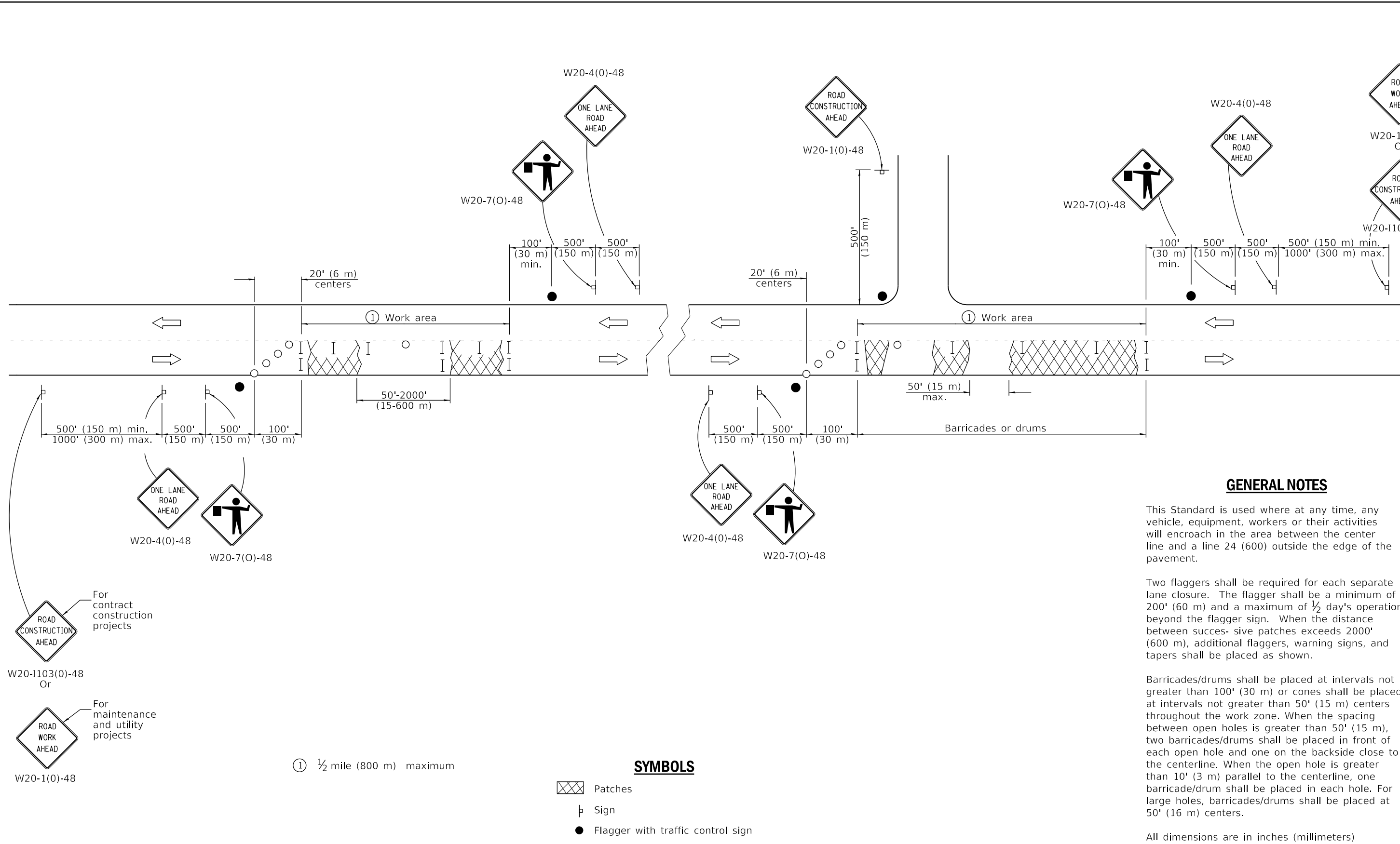

GENERAL NOTES

This Standard is used where at any time, any vehicle, equipment, workers or their activities will encroach in the area between the center line and a line 24 (600) outside the edge of the pavement.

Two flaggers shall be required for each separate lane closure. The flagger shall be a minimum of 200' (60 m) and a maximum of 1/2 day's operation beyond the flagger sign. When the distance between successive patches exceeds 2000' (600 m), additional flaggers, warning signs, and tapers shall be placed as shown.

Barricades/drums shall be placed at intervals not greater than 100' (30 m) or cones shall be placed at intervals not greater than 50' (15 m) centers throughout the work zone. When the spacing between open holes is greater than 50' (15 m), two barricades/drums shall be placed in front of each open hole and one on the backside close to the centerline. When the open hole is greater than 10' (3 m) parallel to the centerline, one barricade/drum shall be placed in each hole. For large holes, barricades/drums shall be placed at 50' (16 m) centers.

All dimensions are in inches (millimeters) unless otherwise shown.

SYMBOLS

- Patches
- Sign
- Flagger with traffic control sign
- Barricade or drum
- Cone, barricade or drum

① 1/2 mile (800 m) maximum

TYPICAL APPLICATIONS

Patching

Illinois Department of Transportation

APPROVED January 1, 2019
Cynthia Watt
 ENGINEER OF SAFETY PROG. AND ENGINEERING

APPROVED January 1, 2019
Joe E. ...
 ENGINEER OF DESIGN AND ENVIRONMENT

ISSUED 1-1-97

DATE	REVISIONS
1-1-19	Revised device spacing in taper.
1-1-11	Revised flagger sign.

**LANE CLOSURE, 2L, 2W,
 WORK AREAS IN SERIES,
 FOR SPEEDS ≥ 45 MPH**

STANDARD 701336-07

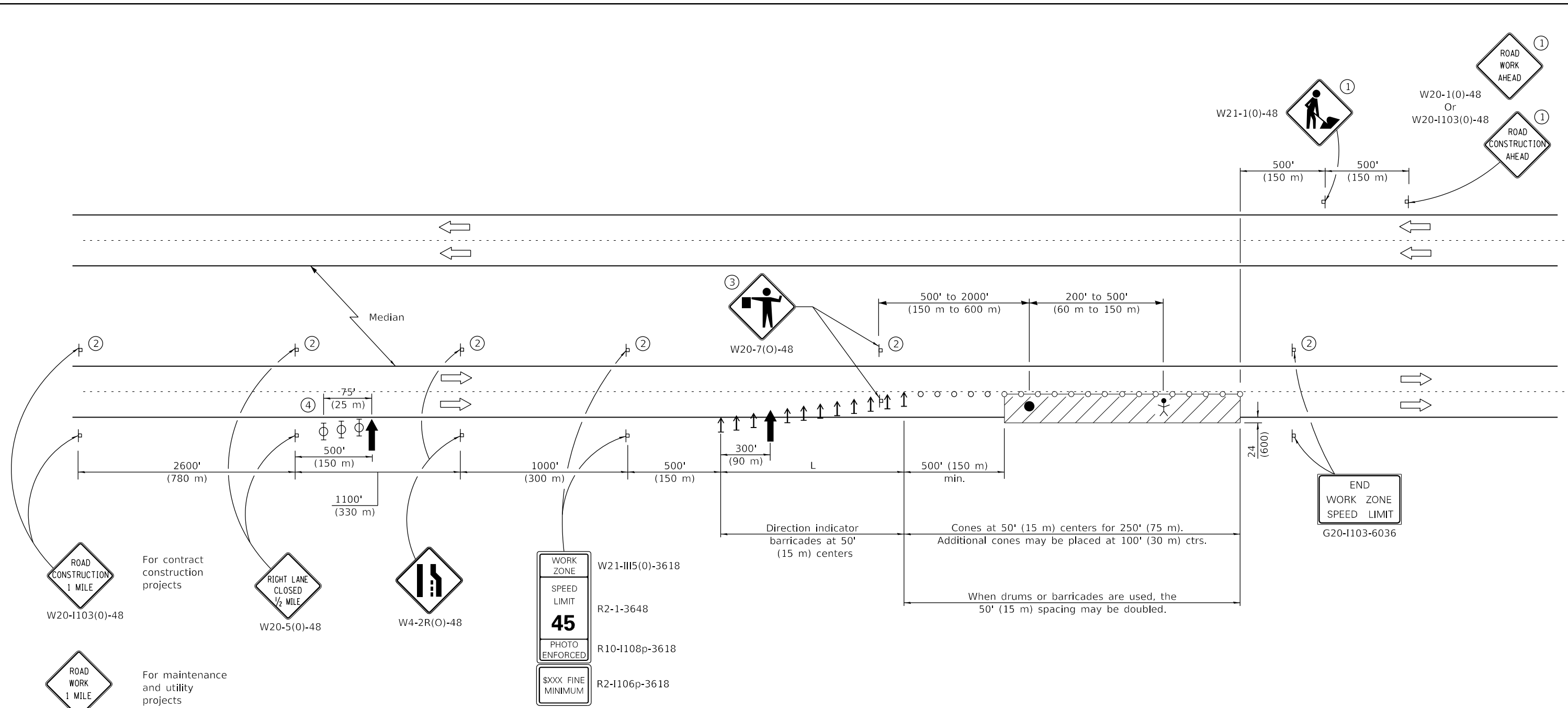

TYPICAL APPLICATIONS

Pavement patch
Utility operations
Bituminous resurfacing

SYMBOLS

- ↑ Arrow board
- ▨ Work area
- ⊥ Sign
- ↑ Direction indicator barricade
- Cone, drum or barricade
- Flagger with traffic control sign
- ⚙ Worker
- ⊕ Type II barricade, drum, or vertical barricade with monodirectional flashing light

L = lane width X taper ratio	
Normal Posted Speed	Taper Ratio
mph	
55	55/1
45	45/1

- ① Undivided roadway only with left lane closure in opposite direction.
- ② Omitted when median is less than 10' (3 m).
- ③ FLAGGER signs shall be moved as necessary to maintain the required spacing between the sign and each separate work activity.
- ④ Three Type II barricades, drums, or vertical barricades at 25' (8 m) centers.

GENERAL NOTES

This Standard is used where at any time, any vehicle, equipment, workers or their activities will encroach on the lane adjacent to the shoulder, or on the shoulder within 24 (600) of the edge of pavement.

This Standard also applies when work is being performed in the left lane. Under these conditions, LEFT LANE CLOSED signs shall be substituted for RIGHT LANE CLOSED signs. On undivided highways, signs shall be added in the opposite direction as shown.

All dimensions are in inches (millimeters) unless otherwise shown.

DATE	REVISIONS
1-1-17	Rev. END WORK ZONE SPEED LIMIT sign. Changed device spacing at first arr. brd.
1-1-15	Revised END WORK ZONE SPEED LIMIT sign dimensions.

LANE CLOSURE, MULTILANE, DAY OPERATIONS ONLY, FOR SPEEDS ≥ 45 MPH TO 55 MPH

STANDARD 701421-08

Illinois Department of Transportation

PASSED January 1, 2017
Paul L. ...
 ENGINEER OF SAFETY PROG. AND ENGINEERING

ISSUED 4-1-04

APPROVED January 1, 2017
Maureen M. ...
 ENGINEER OF DESIGN AND ENVIRONMENT

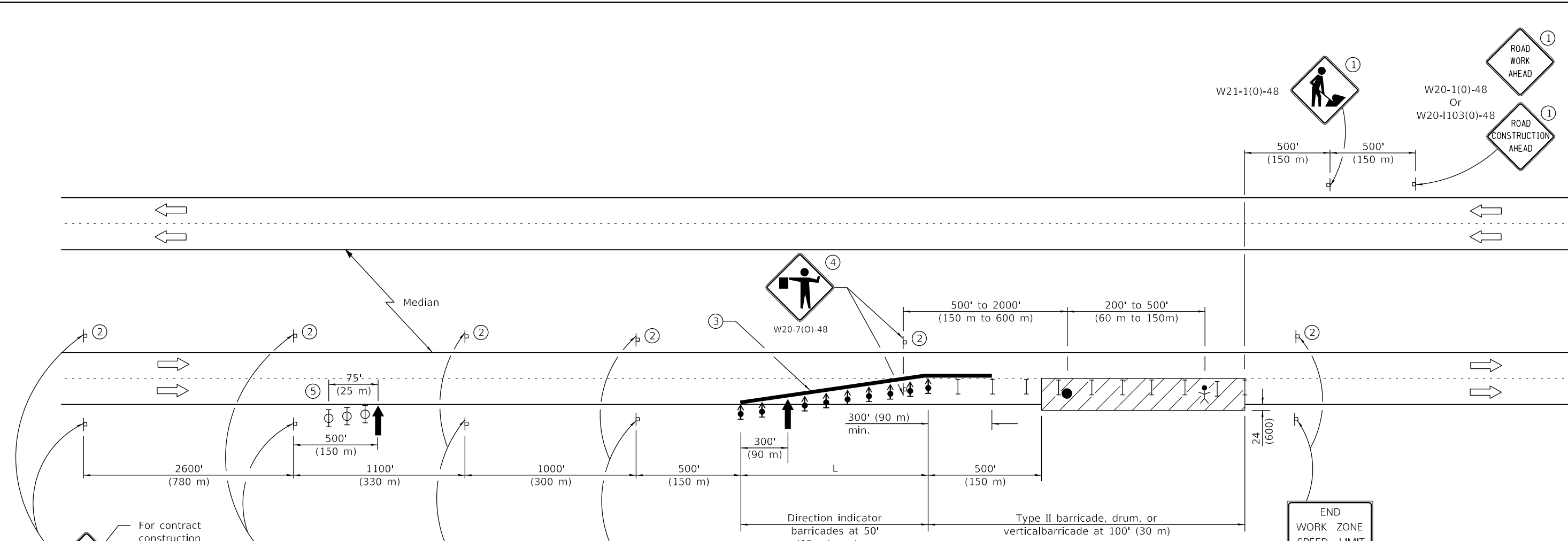

For contract construction projects
 ROAD CONSTRUCTION 1 MILE
 W20-1103(0)-48

RIGHT LANE CLOSED 1/2 MILE
 W20-5(0)-48

W4-2R(0)-48

For maintenance and utility projects
 ROAD WORK 1 MILE
 W20-1(0)-48

L = lane width X taper ratio	
Normal Posted Speed	Taper Ratio
mph	
55	55/1
45	45/1

WORK ZONE W21-III5(0)-3618
 SPEED LIMIT R2-1-3648
45
 PHOTO ENFORCED R10-1108p-3618
 SXXX FINE MINIMUM R2-1106p-3618

SYMBOLS

- Arrow board
- Work area
- Sign
- Direction indicator barricade with steady burn monodirectional light
- Type II barricade, drum, or vertical barricade
- Flagger with traffic control sign
- Worker
- Type II barricade, drum, or vertical barricade with monodirectional flashing light

- ① Undivided roadway only with left lane closure in opposite direction.
- ② Omitted when median is less than 10' (3 m).
- ③ ReflectORIZED temporary pavement marking tape shall be placed throughout the taper and for 300' (90 m) along-side the work area where the closure time is greater than fourteen days. The edge line shall be white for right lane closures and yellow for left lane closures.
- ④ FLAGGER signs shall be moved as necessary to maintain the required spacing between the sign and each separate work activity.
- ⑤ Three Type II barricades, drums, or vertical barricades at 25' (8 m) centers.

GENERAL NOTES

This standard is used where at any time any vehicle, equipment, workers or their activities will encroach on the lane adjacent to the shoulder, or on the shoulder within 24 (600) of the edge of pavement for daylight operation exceeding one day.

This standard also applies when work is being performed in the left lane. Under these conditions LEFT LANE CLOSED signs shall be substituted for RIGHT LANE CLOSED signs. On undivided highways, signs shall be added in the opposite direction as shown.

A check barricade shall be placed in the middle of the closed lane and at the shoulder at 1000' (300 m) centers.

All dimensions are in inches (millimeters) unless otherwise shown.

DATE	REVISIONS
1-1-18	Omitted lights in tangent.
1-1-17	Rev. END WORK ZONE SPEED LIMIT sign. Changed device spacing at first arr. brd.

LANE CLOSURE, MULTILANE, FOR SPEEDS ≥ 45 MPH TO 55 MPH

STANDARD 701422-10

Illinois Department of Transportation

PASSED January 1, 2018
 [Signature]
 ENGINEER OF SAFETY PROG. AND ENGINEERING

APPROVED January 1, 2018
 [Signature]
 ENGINEER OF DESIGN AND ENVIRONMENT

ISSUED 4-1-04

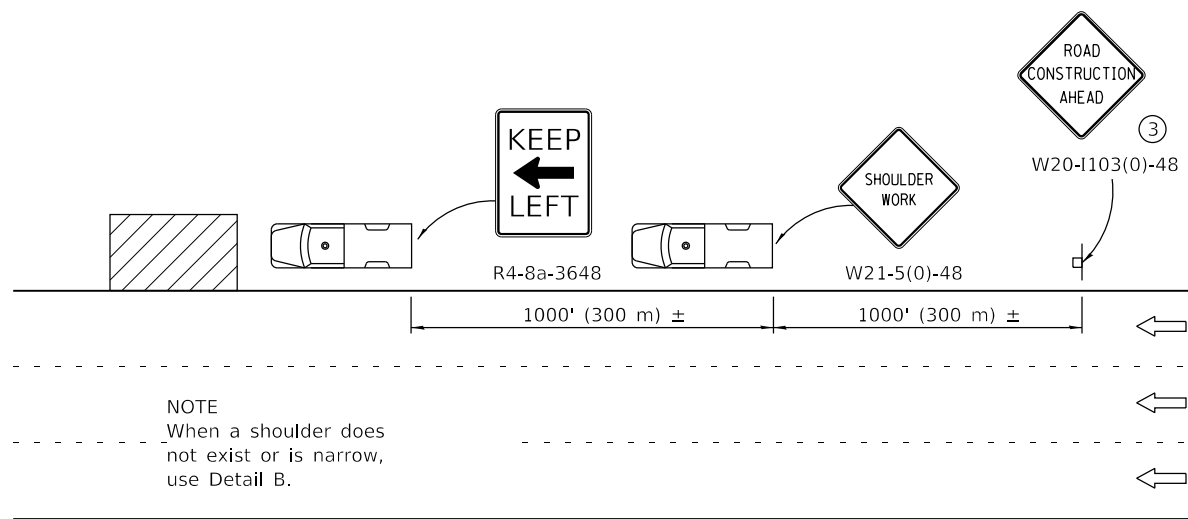

DETAIL A

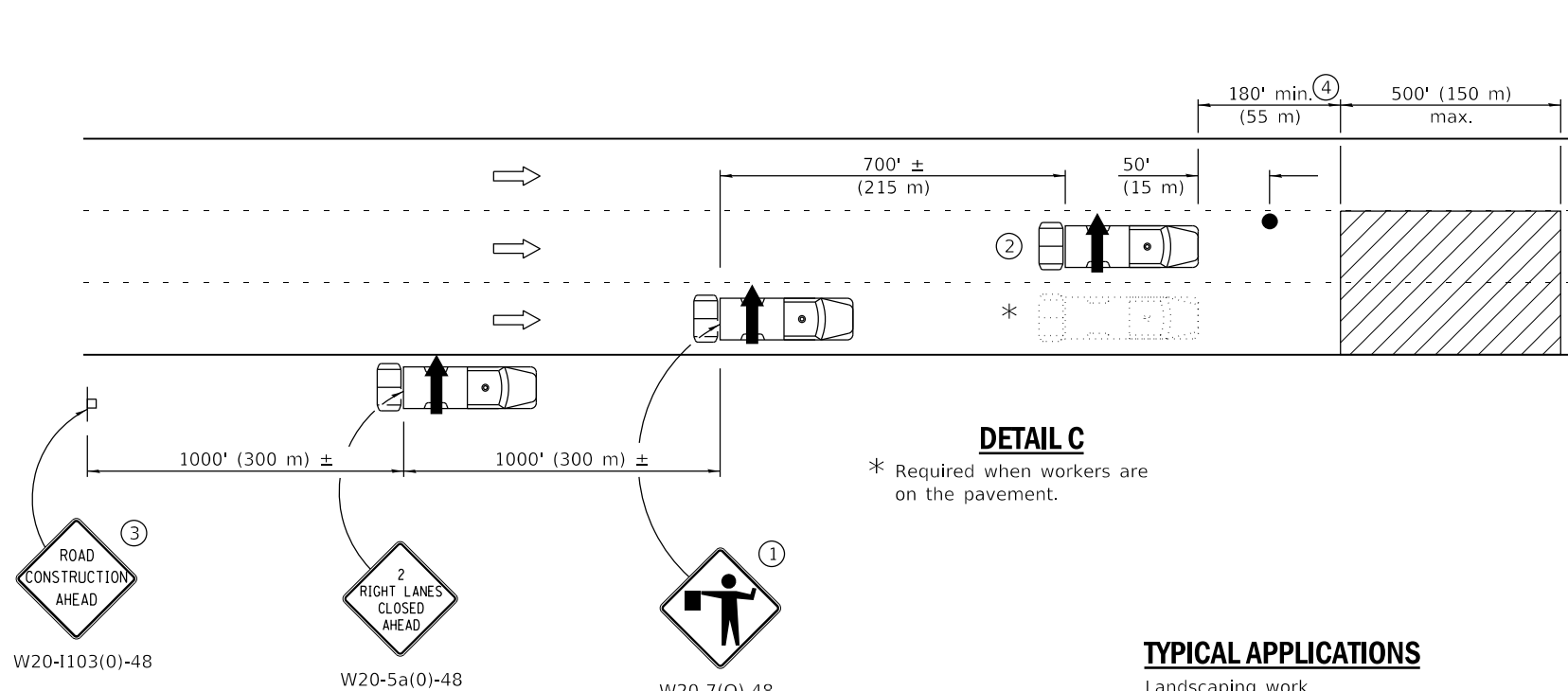

DETAIL C

TYPICAL APPLICATIONS

- Landscaping work
- Utility work
- Pavement marking
- Weed spraying
- Roadometer measurements
- Debris cleanup
- Crack pouring

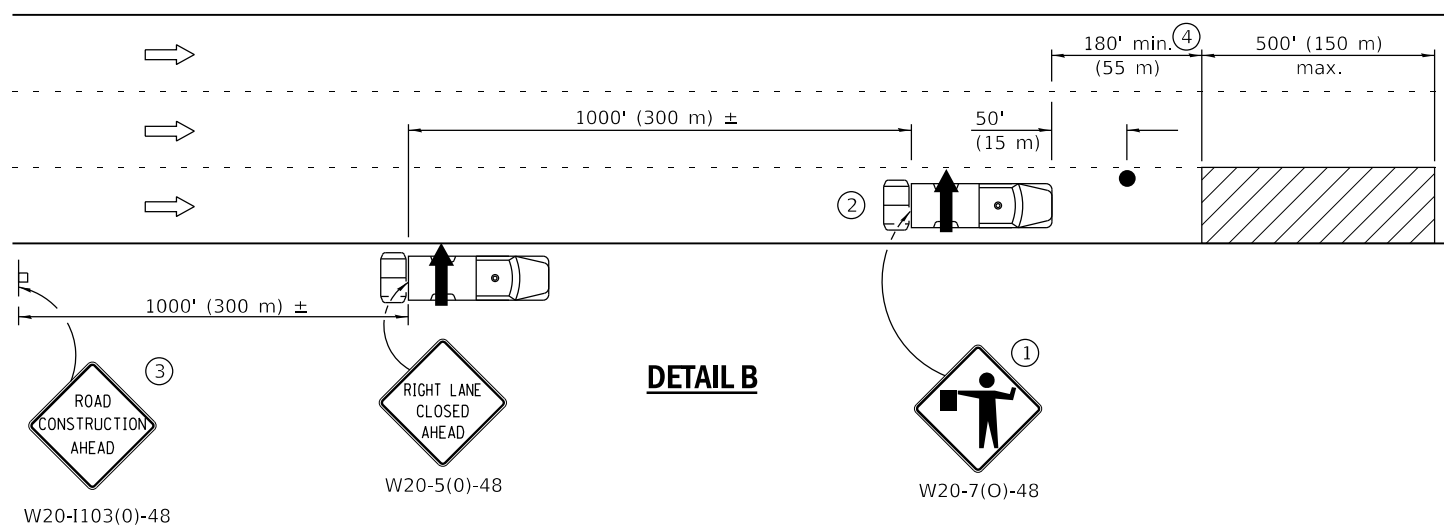

DETAIL B

- ① Flaggers are required when workers are on the pavement.
- ② For striping operations only. See sign arrow detail on this standard.
- ③ For stationary operations which are on the roadway or shoulder, greater than 15 minutes and up to 1 hour.
- ④ The distance between the work and the lead truck may vary according to terrain or paint/crack sealing drying time.



G20-1101-2430
(appropriate arrow)
② (when striping only)

GENERAL NOTES

This Standard is used where any vehicle, equipment, workers or their activities will require: 1) stationary operations up to 1 hour, or 2) a continuous or intermittent moving operation where the average speed of movement is greater than 1 mph (2 km/h).

This Standard is also applicable when work is being performed in the left lane(s) or on the median shoulder. Under these conditions, KEEP RIGHT signs shall be substituted for KEEP LEFT signs and arrow board indications shall be directed to the right.

All dimensions are in inches (millimeter) unless otherwise shown.

SYMBOLS

- ↑ Arrow board
- ▨ Work area
- Truck with flashing amber light
- Truck/Trailer mounted attenuator
- Flagger with traffic control sign
- Sign

Illinois Department of Transportation

PASSED January 1, 2017
Paul L. ...
 ENGINEER OF SAFETY PROG. AND ENGINEERING

ISSUED 1-1-97

APPROVED January 1, 2017
Maureen M. ...
 ENGINEER OF DESIGN AND ENVIRONMENT

DATE	REVISIONS
1-1-17	Revised 'NOTE' on DETAIL A to use DETAIL B in lieu of DETAIL C.
4-1-16	Added trailer option for attenuator symbol. Added note ④. Revised gen. notes.

LANE CLOSURE, MULTILANE, INTERMITTENT OR MOVING OPER., FOR SPEEDS ≥ 45 MPH

STANDARD 701426-09

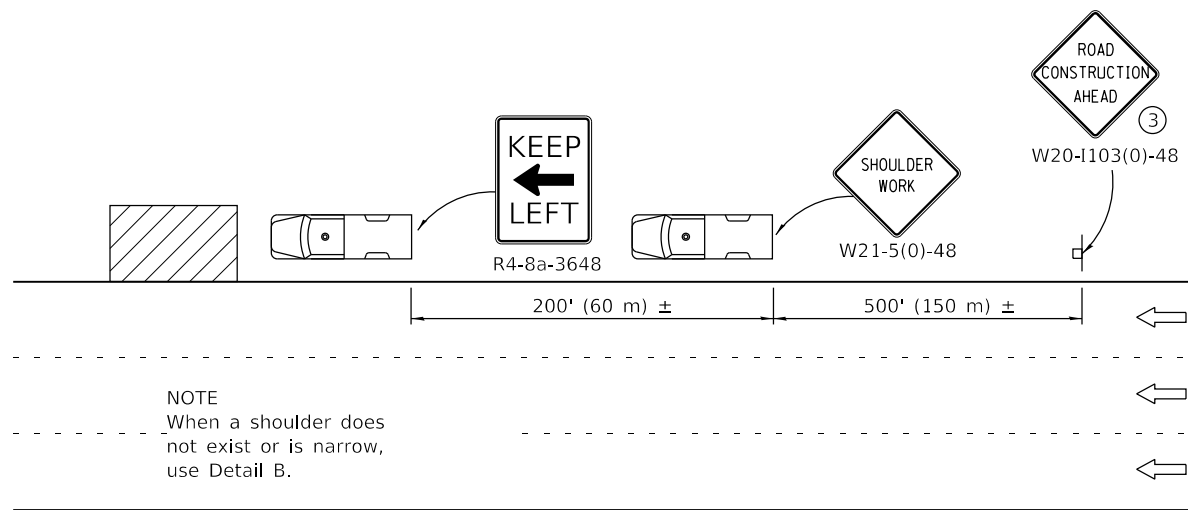

DETAIL A

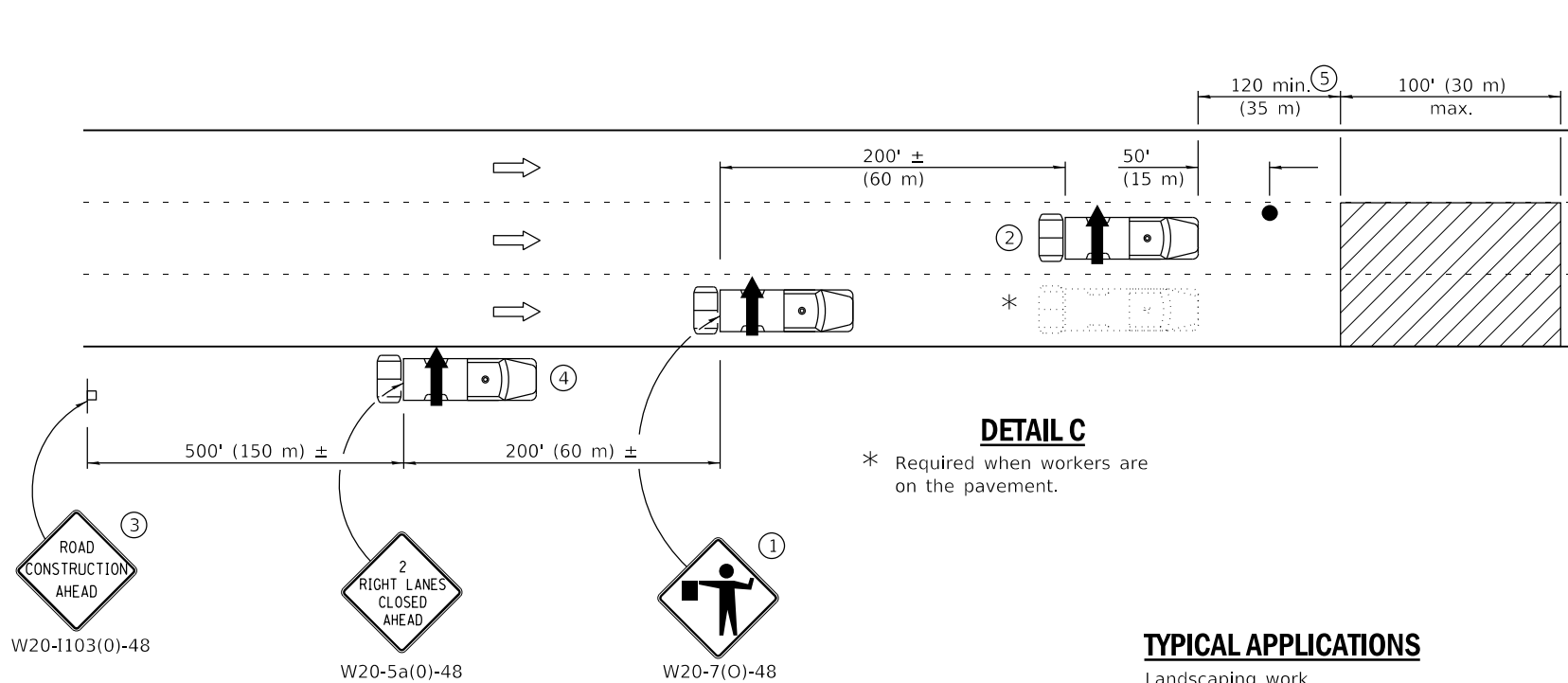

DETAIL C

* Required when workers are on the pavement.

TYPICAL APPLICATIONS

- Landscaping work
- Utility work
- Pavement marking
- Weed spraying
- Roadometer measurements
- Debris cleanup
- Crack pouring

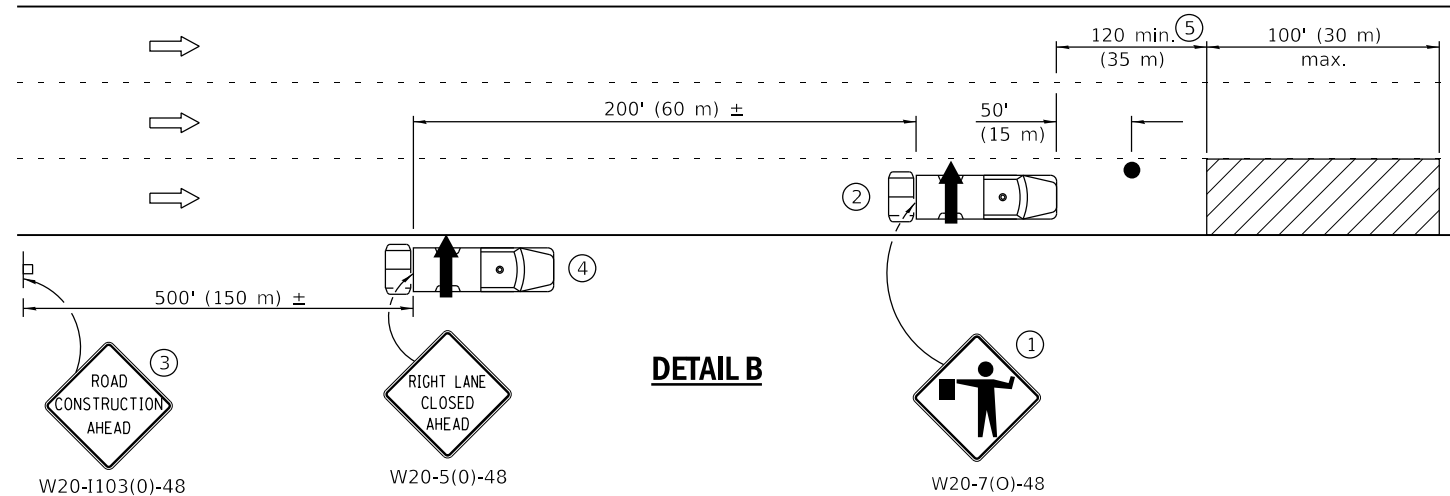

DETAIL B

- ① Flagger is required when workers are on the pavement.
- ② For striping operations only. See sign arrow detail on this standard.
- ③ For stationary operations which are on the roadway or shoulder, greater than 15 minutes and up to 1 hour.
- ④ Omit truck, attenuator and arrow board when no shoulder exists due to curb and gutter.
- ⑤ The distance between the work and the lead truck may vary according to terrain or paint/crack sealing time.



G20-1101-2430 (appropriate arrow) ② (when striping only)

GENERAL NOTES

This Standard is used where any vehicle, equipment, workers or their activities will require: 1) stationary operations up to 1 hour, or 2) a continuous or intermittent moving operation where the average speed of movement is greater than 1 mph (2 km/h).

This Standard is also applicable when work is being performed in the left lane(s) or on the median shoulder. Under these conditions, KEEP RIGHT signs shall be substituted for KEEP LEFT signs and arrow board indications shall be directed to the right.

All dimensions are in inches (millimeter) unless otherwise shown.

SYMBOLS

- Arrow board
- Work area
- Truck with flashing amber light
- Truck/Trailer mounted attenuator
- Flagger with traffic control sign
- Sign

DATE	REVISIONS
1-1-17	Revised 'NOTE' on DETAIL A to use DETAIL B in lieu of DETAIL C.
4-1-16	Rev. gen. notes. Added note ⑤. Rev. dist. between work and lead truck.

LANE CLOSURE, MULTILANE, INTERMITTENT OR MOVING OPER., FOR SPEEDS ≤ 40 MPH

STANDARD 701427-05

Illinois Department of Transportation

PASSED January 1, 2017

APPROVED January 1, 2017

ISSUED 1-1-17

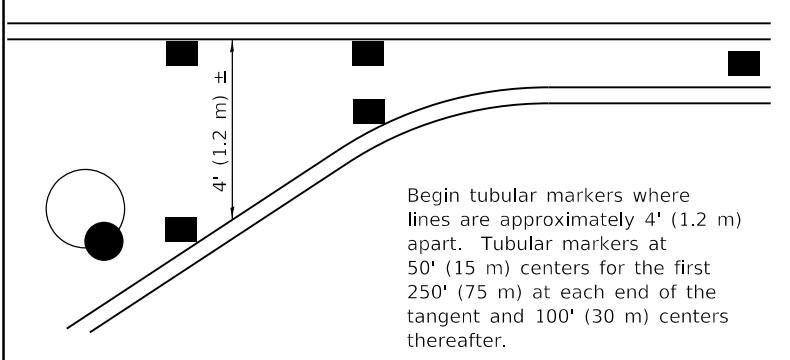
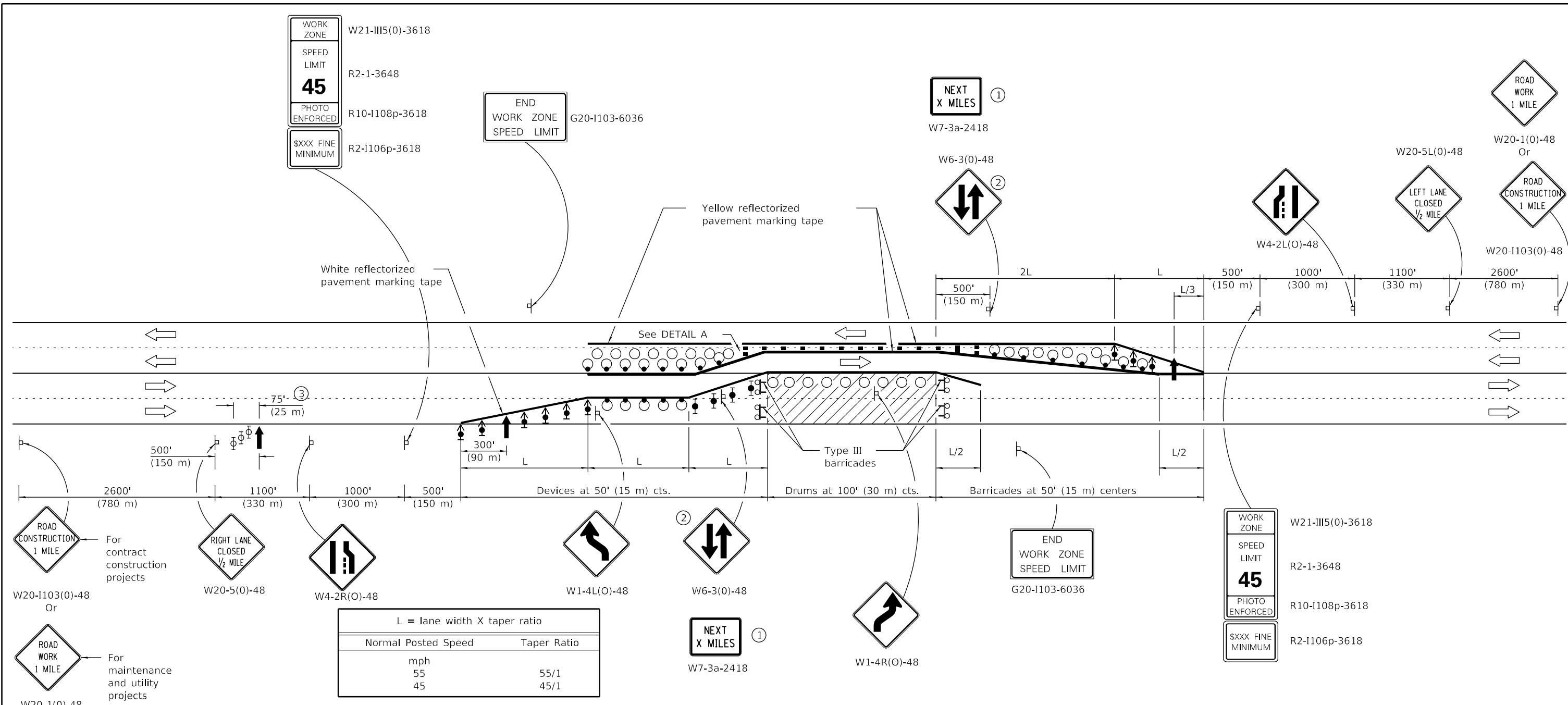

DETAIL A

SYMBOLS

- Arrow board
- Work area
- Sign
- Drum with steady burn monodirectional light
- Direction indicator barricade with steady burn monodirectional light
- Type II barricade with steady burn monodirectional light
- Type II barricade, drum or vertical barricade with monodirectional flashing light
- Tubular marker
- Type III barricade with flashing monodirectional lights
- Drum

- ① Shall be repeated every 1 mile (1.6 km).
- ② Shall be repeated every 1 mile (1.6 km) in each direction in the tangent section unless concrete barrier is used.
- ③ Three Type II barricades, drums or vertical barricades at 25' (8 m) centers.

GENERAL NOTES

This Standard is used where at any time, any vehicle, equipment, workers or their activities require the closure of two adjacent lanes and a temporary crossover is provided by making use of one lane of pavement normally used by opposing flow of traffic and flexible delineators are used to separate the opposing traffic.

Cones may be substituted for flexible delineators during daytime operations at half the spacing.

All dimensions are in inches (millimeters) unless otherwise shown.

DATE	REVISIONS
1-1-18	Omitted lights on drums in tangent for westbound traffic and at work area.
1-1-17	Replaced W18-1100 plaque with W7-3a plaque. Changed flexible delineator to tubular marker.

LANE CLOSURE, MULTILANE, UNDIV. WITH CROSSOVER, FOR SPEEDS ≥ 45 MPH TO 55 MPH

STANDARD 701431-13

Illinois Department of Transportation

PASSED January 1, 2018

APPROVED January 1, 2018

ISSUED 1-1-97

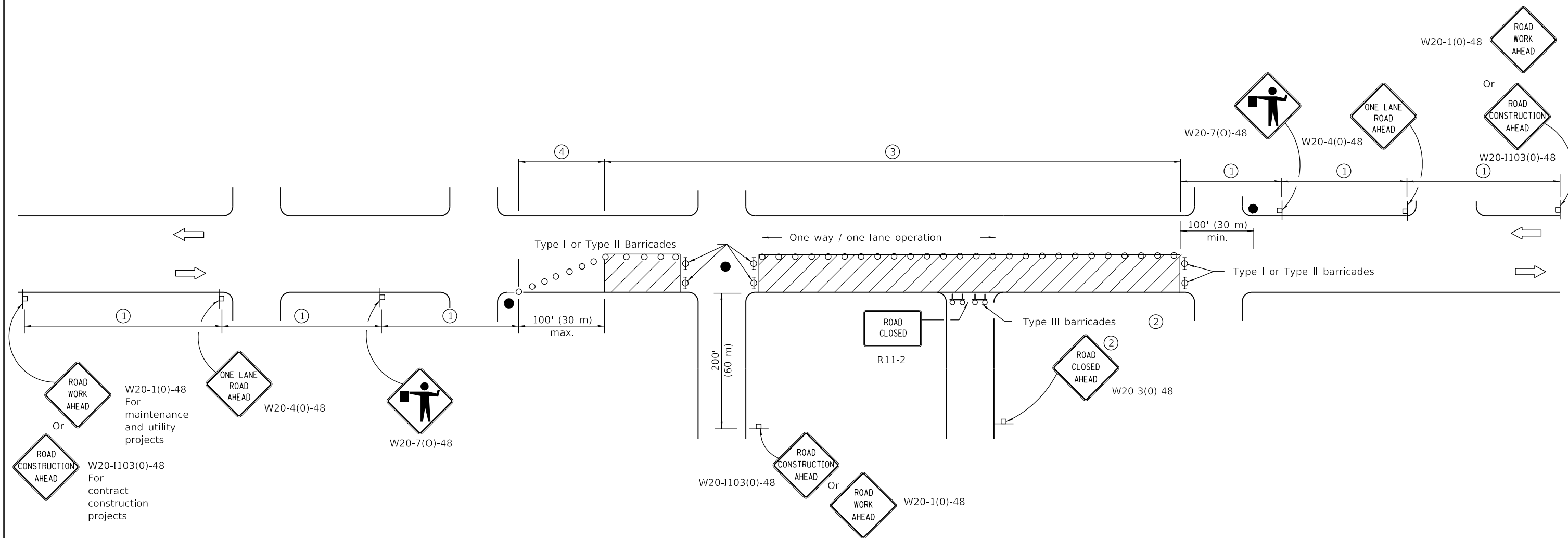

SIGN SPACING	
Posted Speed	Sign Spacing
55	500' (150 m)
50-45	350' (100 m)
<45	200' (60 m)

SYMBOLS

- Work area
- Cone, drum or barricade (not required for moving operations)
- Sign on portable or permanent support
- Flagger with traffic control sign
- Barricade or drum with flashing light
- Type III barricade with flashing lights

- ① Refer to SIGN SPACING TABLE for distances.
- ② For approved sideroad closures.
- ③ Cones at 25' (8 m) centers for 250' (75 m). Additional cones may be placed at 50' (15 m) centers. When drums or Type I or Type II barricades are used, the interval between devices may be doubled.
- ④ Cones, drums or barricades at 20' (6 m) centers.

GENERAL NOTES

This Standard is used where at any time, day or night, any vehicle, equipment, workers or their activities encroach on the pavement requiring the closure of one traffic lane in an urban area.

All dimensions are in inches (millimeters) unless otherwise shown.

Illinois Department of Transportation

PASSED January 1, 2011
 ENGINEER OF SAFETY ENGINEERING

APPROVED January 1, 2011
 ENGINEER OF DESIGN AND ENVIRONMENT



ISSUED 1-1-97

DATE	REVISIONS
1-1-11	Revised flagger sign.
1-1-09	Switched units to English (metric).
	Corrected sign No.'s.

**URBAN LANE CLOSURE,
2L, 2W, UNDIVIDED**

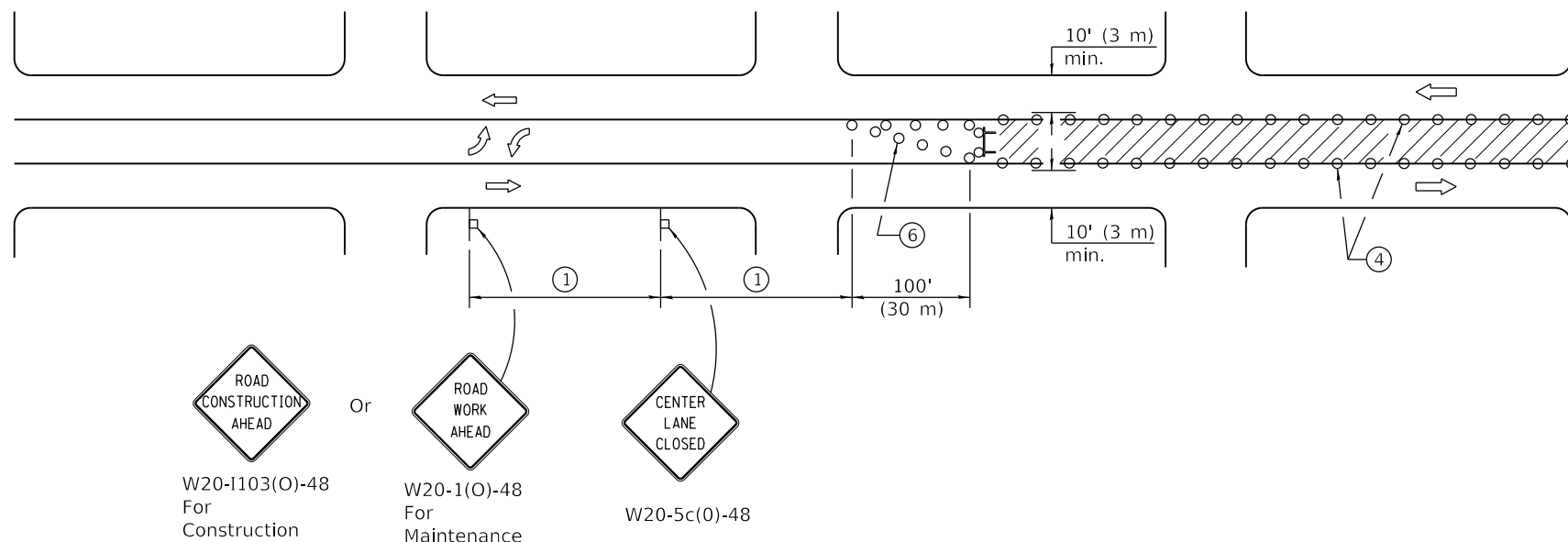
STANDARD 701501-06



 W20-1103(O)-48 For Construction
 Or
 W20-1(O)-48 For Maintenance
 W20-5c(O)-48







CASE I

(Signs required for both directions)

SIGN SPACING	
Posted Speed	Sign Spacing
55	500' (150 m)
50-45	350' (100 m)
<45	200' (60 m)

- ① Refer to SIGN SPACING TABLE for distances.
- ② Required for speeds > 40 mph (70 km/h).
- ③ Required if work exceeds 500' (164 m) or 1 block.
- ④ Cones at 25' (8 m) centers for 250' (75 m) on approach. Additional cones may be placed at 50' (15 m) centers. When drums or type I or II barricades are used, the interval between devices may be doubled.
- ⑤ For approved sideroad closures.
- ⑥ Cones, drums or barricades at 20' (6 m) centers in taper.
- ⑦ Use flagger sign only when flagger is present.

SYMBOLS

-  Work area
-  Barricade or drum with flashing light
-  Flagger with traffic control sign
-  Cone, drum or barricade
-  Sign on portable or permanent support
-  Type III barricade with flashing lights

GENERAL NOTES

This Standard is used to close one lane of an urban, two lane, two way roadway with a bidirectional turn lane.

Case I applies when no workers are present. When workers are present, two lanes shall be closed and traffic control shall be according to Standard 701501.

Calculate L as follows:

SPEED LIMIT	FORMULAS	
	English	(Metric)
40 mph (70 km/h) or less:	$L = \frac{WS^2}{60}$	$L = \frac{WS^2}{150}$
45 mph (80 km/h) or greater:	$L = (W)(S)$	$L = 0.65(W)(S)$

W = Width of offset in feet (meters).
 S = Normal posted speed mph (km/h).

All dimensions are in inches (millimeters) unless otherwise shown.

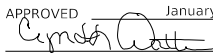
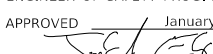
 Illinois Department of Transportation
 APPROVED January 1, 2019

 ENGINEER OF SAFETY PROG. AND ENGINEERING
 APPROVED January 1, 2019

 ENGINEER OF DESIGN AND ENVIRONMENT

ISSUED 1-1-01

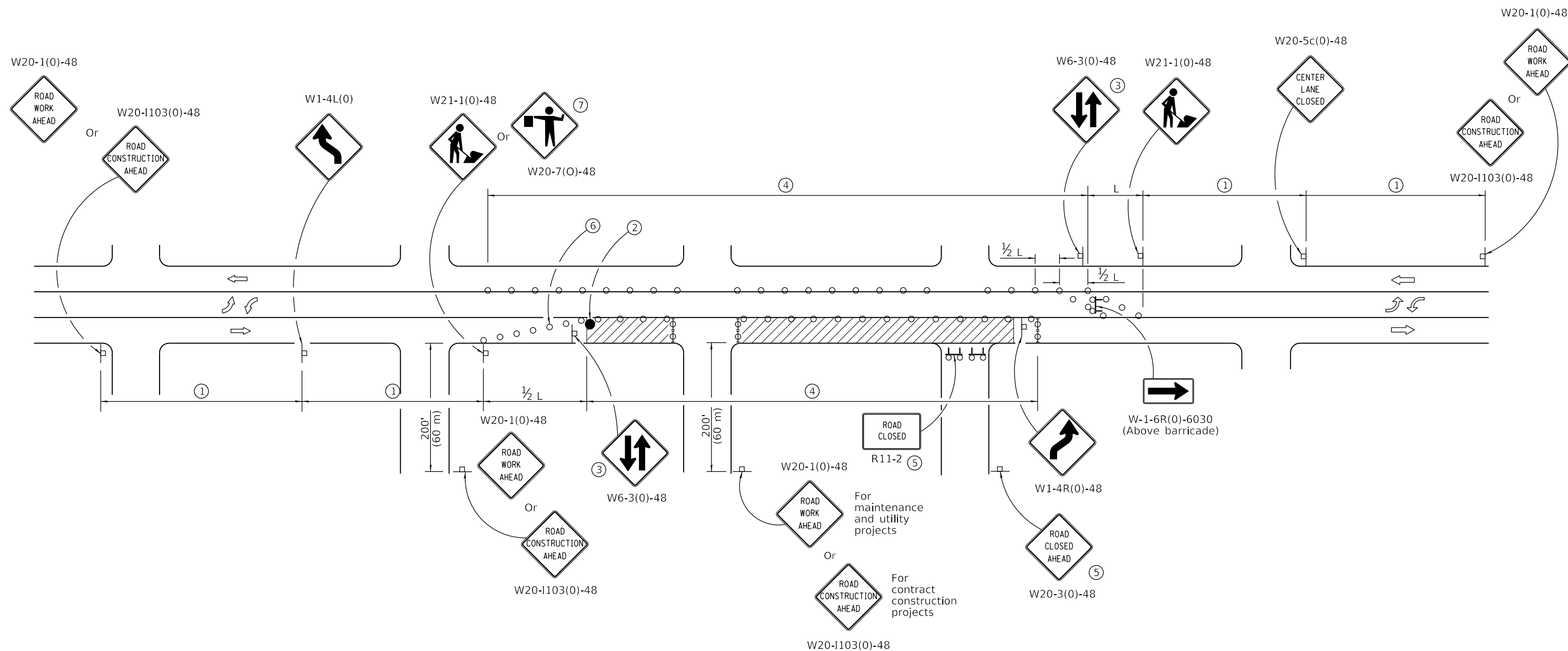
DATE	REVISIONS
1-1-19	Revised to allow cones at night.
1-1-18	Corrected sign number for TWO WAY TRAFFIC sign for CASE II.

**URBAN LANE CLOSURE,
 2L, 2W, WITH BIDIRECTIONAL
 LEFT TURN LANE**
 (Sheet 1 of 2)
STANDARD 701502-09



CASE II

Illinois Department of Transportation

APPROVED January 1, 2019
Cynthia Watt
 ENGINEER OF SAFETY PROG. AND ENGINEERING

APPROVED January 1, 2019
J. E. ...
 ENGINEER OF DESIGN AND ENVIRONMENT

ISSUED 1-1-01

**URBAN LANE CLOSURE,
 2L, 2W, WITH BIDIRECTIONAL
 LEFT TURN LANE**

(Sheet 2 of 2)

STANDARD 701502-09

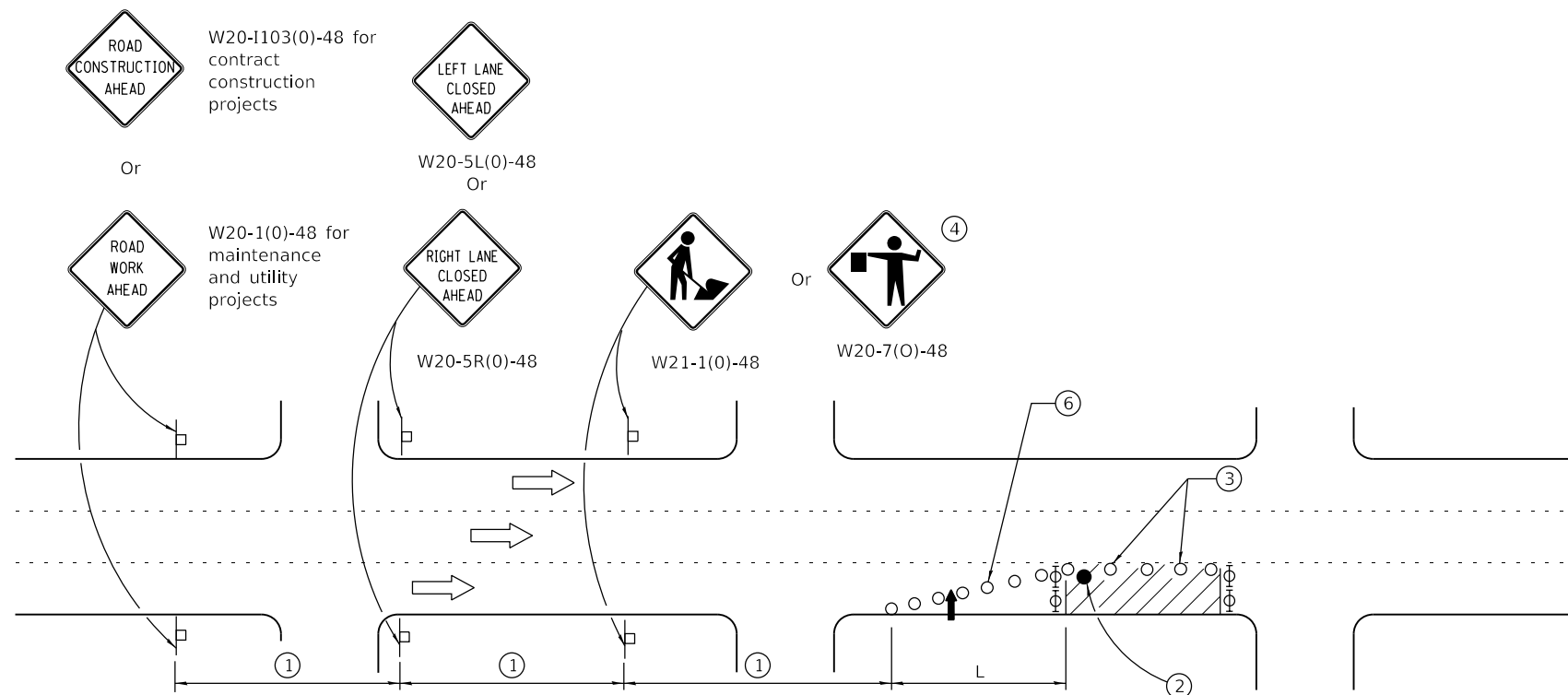

SIGN SPACING	
Posted Speed	Sign Spacing
55	500' (150 m)
50-45	350' (100 m)
<45	200' (60 m)

SYMBOLS

- Arrow board
- Cone, drum or barricade
- Sign on portable or permanent support
- Work area
- Barricade or drum with flashing light
- Type III barricade with flashing lights
- Flagger with traffic control sign.

- ① Refer to SIGN SPACING TABLE for distances.
- ② Required for speeds > 40 MPH
- ③ Cones at 25' (8 m) centers for 250' (75 m). Additional cones may be placed at 50' (15 m) centers. When drums or Type I or Type II barricades are used, the interval between devices may be doubled.
- ④ Use flagger sign only when flagger is present.
- ⑤ For approved sideroad closures.
- ⑥ Cones, drums or barricades at 20' (6 m) in taper.

GENERAL NOTES

This Standard is used where at any time, day or night, any vehicle, equipment, workers or their activities encroach on the pavement during shoulder operations or where construction requires lane closures in urban areas.

Calculate L as follows:

SPEED LIMIT	FORMULAS	
	English	(Metric)
40 mph (70 km/h) or less:	$L = \frac{WS^2}{60}$	$L = \frac{WS^2}{150}$
45 mph (80 km/h) or greater:	$L = (W)(S)$	$L = 0.65(W)(S)$

W = Width of offset in feet (meters).

S = Normal posted speed mph (km/h).

All dimensions are in inches (millimeters) unless otherwise shown.

Illinois Department of Transportation

PASSED January 1, 2014

 ENGINEER OF SAFETY ENGINEERING

ISSUED 1-1-97

APPROVED January 1, 2014

 ENGINEER OF DESIGN AND ENVIRONMENT

DATE	REVISIONS
1-1-14	Revised workers sign number to agree with current MUTCD.
1-1-13	Omitted text 'WORKERS' sign.

URBAN LANE CLOSURE, MULTILANE, 1W OR 2W WITH NONTRAVERSABLE MEDIAN
 (Sheet 1 of 2)

STANDARD 701601-09

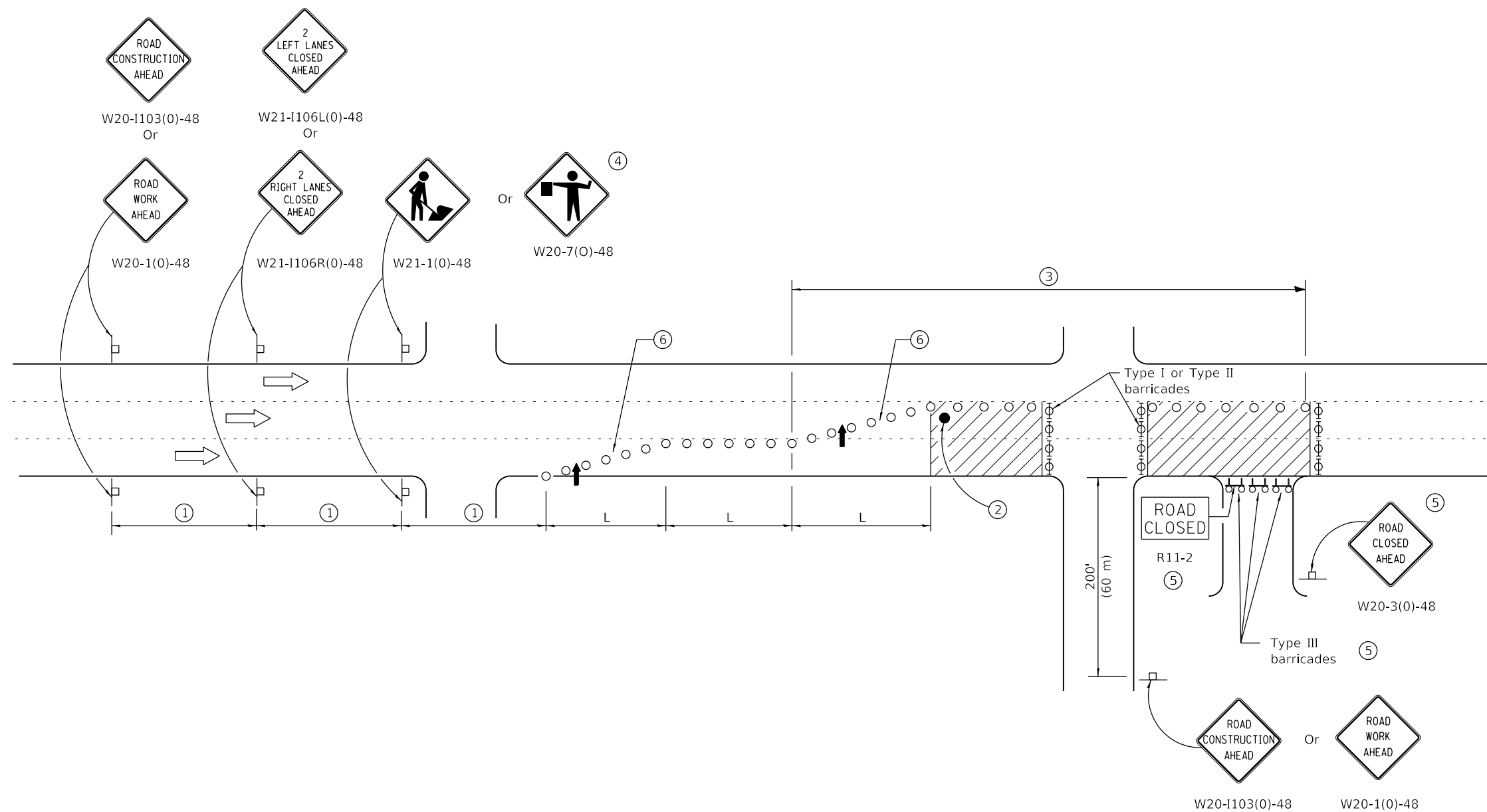

Illinois Department of Transportation

PASSED January 1, 2014

[Signature]
ENGINEER OF SAFETY ENGINEERING

APPROVED January 1, 2014

[Signature]
ENGINEER OF DESIGN AND ENVIRONMENT

ISSUED 1-1-97

**URBAN LANE CLOSURE,
MULTILANE, 1W OR 2W WITH
NONTRAVERSABLE MEDIAN**





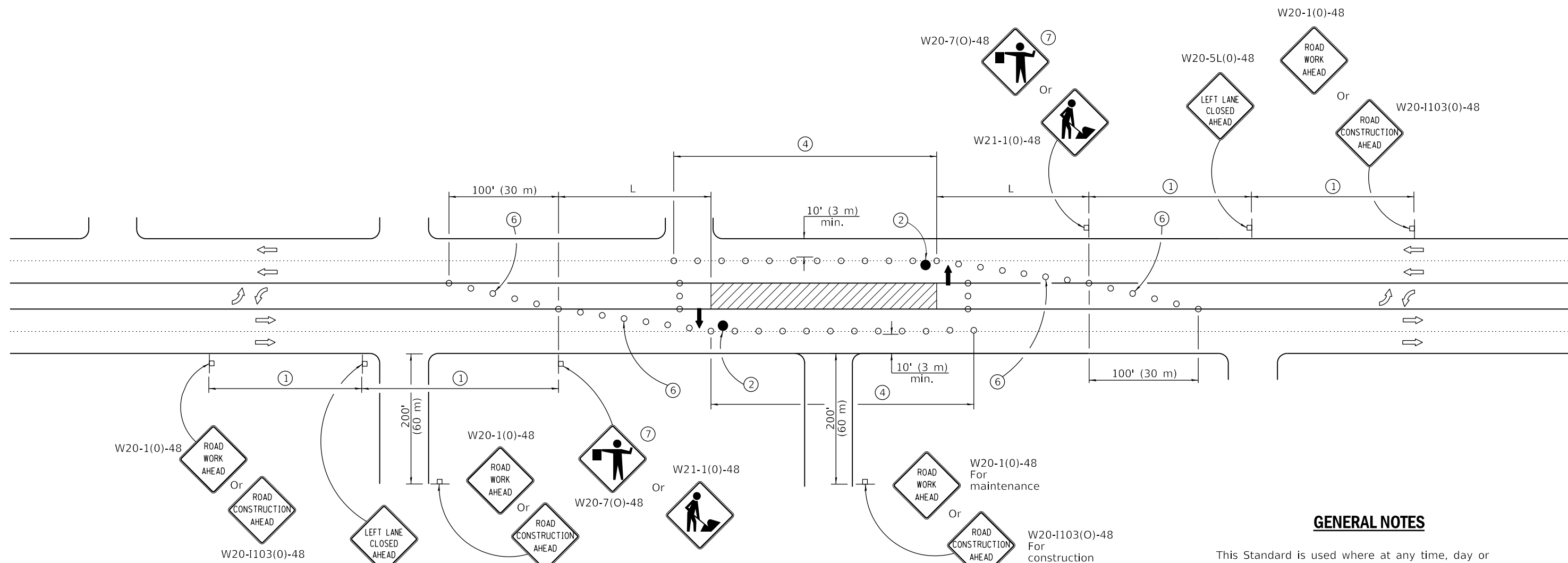

(Sheet 2 of 2)

STANDARD 701601-09



SIGN SPACING	
Posted Speed	Sign Spacing
55	500' (150 m)
50-45	350' (100 m)
<45	200' (60 m)

SYMBOLS

-  Arrow board
-  Work area
-  Barricade or drum with steady burning mondirectional light
-  Flagger with traffic control sign
-  Cone, drum or barricade
-  Sign on portable or permanent support
-  Type III barricade with flashing lights

CASE I

- ① Refer to SIGN SPACING TABLE for distances.
- ② Required for speeds > 40 mph (70 km/h).
- ③ Required if work exceeds 500' (164 m) or 1 block, repeat every 1 mile (1.6 km).
- ④ Cones at 25' (8 m) centers for 250' (75 m) on approach. Additional cones may be placed at 50' (15 m) centers. When drums or type I or II barricades are used, the interval between devices may be doubled.
- ⑤ For approved sideroad closures.
- ⑥ Cones, drums or barricades at 20' (6 m) centers in taper.
- ⑦ Use flagger sign only when flagger is present.

GENERAL NOTES

This Standard is used where at any time, day or night, any vehicle, equipment, workers or their activities encroach on the pavement requiring the closure of one traffic lane in an Urban area.

If the work operation is performed between 9:00 a.m. and 3:00 p.m. and does not exceed 15 min. Traffic protection shall be as shown for Standard 701426.

Calculate L as follows:

SPEED LIMIT	FORMULAS	
	English	(Metric)
40 mph (70 km/h) or less:	$L = \frac{WS^2}{60}$	$L = \frac{WS^2}{150}$
45 mph (80 km/h) or greater:	$L=(W)(S)$	$L=0.65(W)(S)$

W = Width of offset in feet (meters).

S = Normal posted speed mph (km/h).

All dimensions are in inches (millimeters) unless otherwise shown.

DATE	REVISIONS
1-1-19	Revised to allow cones at night.
1-1-18	Moved arrow boards into closed lanes for CASE I.

URBAN LANE CLOSURE, MULTILANE, 2W WITH BIDIRECTIONAL LEFT TURN LANE

(Sheet 1 of 4)

STANDARD 701602-10

Illinois Department of Transportation

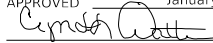
APPROVED January 1, 2019

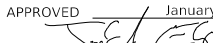
 ENGINEER OF SAFETY PROG. AND ENGINEERING

APPROVED January 1, 2019

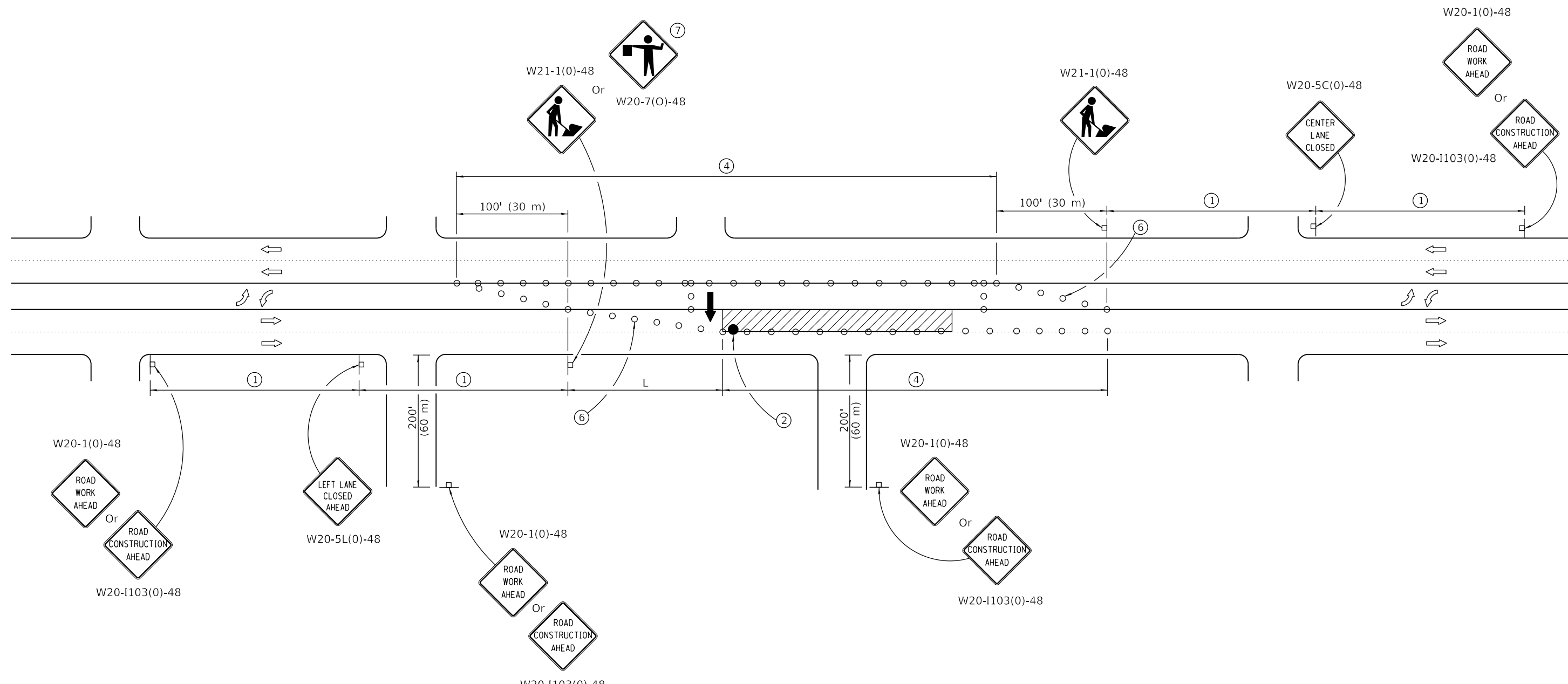
 ENGINEER OF DESIGN AND ENVIRONMENT

ISSUED 1-1-13



CASE III

Illinois Department of Transportation

APPROVED January 1, 2019
Cynthia Watt
 ENGINEER OF SAFETY PROG. AND ENGINEERING

APPROVED January 1, 2019
J. E. C.
 ENGINEER OF DESIGN AND ENVIRONMENT

ISSUED 1-1-13

**URBAN LANE CLOSURE,
 MULTILANE, 2W WITH
 BIDIRECTIONAL LEFT TURN LANE**

(Sheet 3 of 4)

STANDARD 701602-10

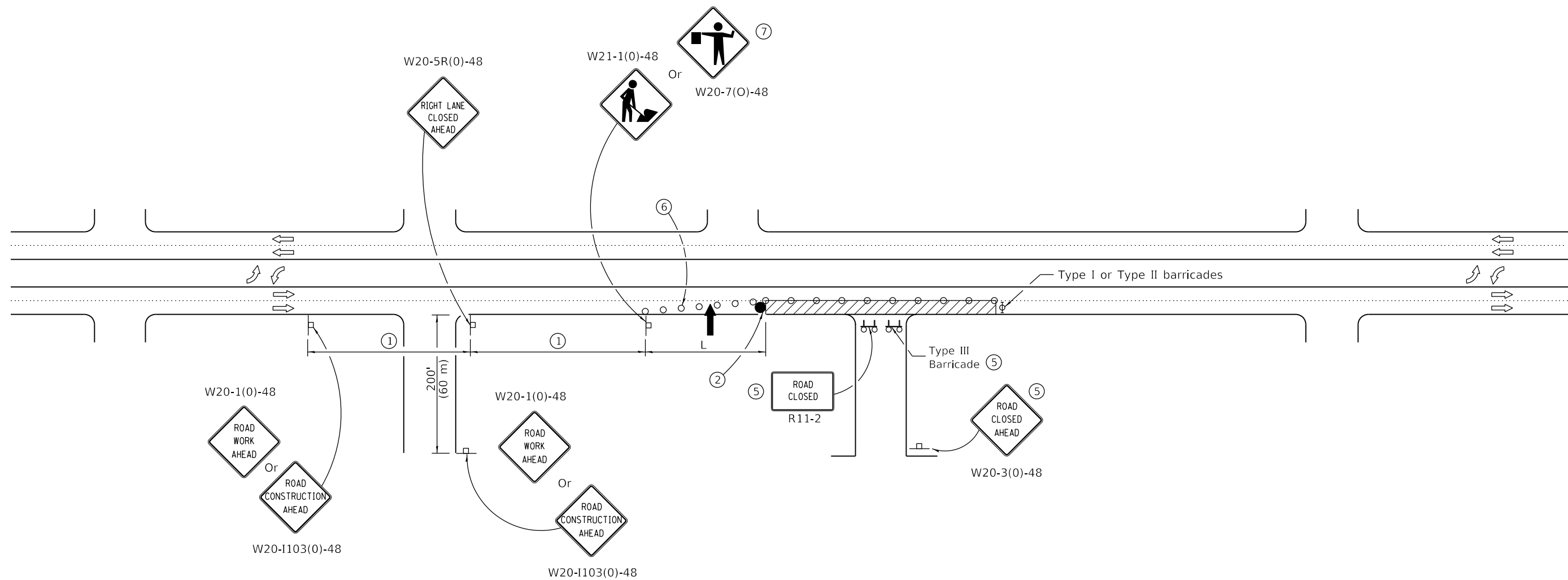

CASE IV

Illinois Department of Transportation

APPROVED January 1, 2019
Cynthia Watt
 ENGINEER OF SAFETY PROG. AND ENGINEERING

APPROVED January 1, 2019
J. E. ...
 ENGINEER OF DESIGN AND ENVIRONMENT

ISSUED 1-1-13

**URBAN LANE CLOSURE,
 MULTILANE, 2W WITH
 BIDIRECTIONAL LEFT TURN LANE**





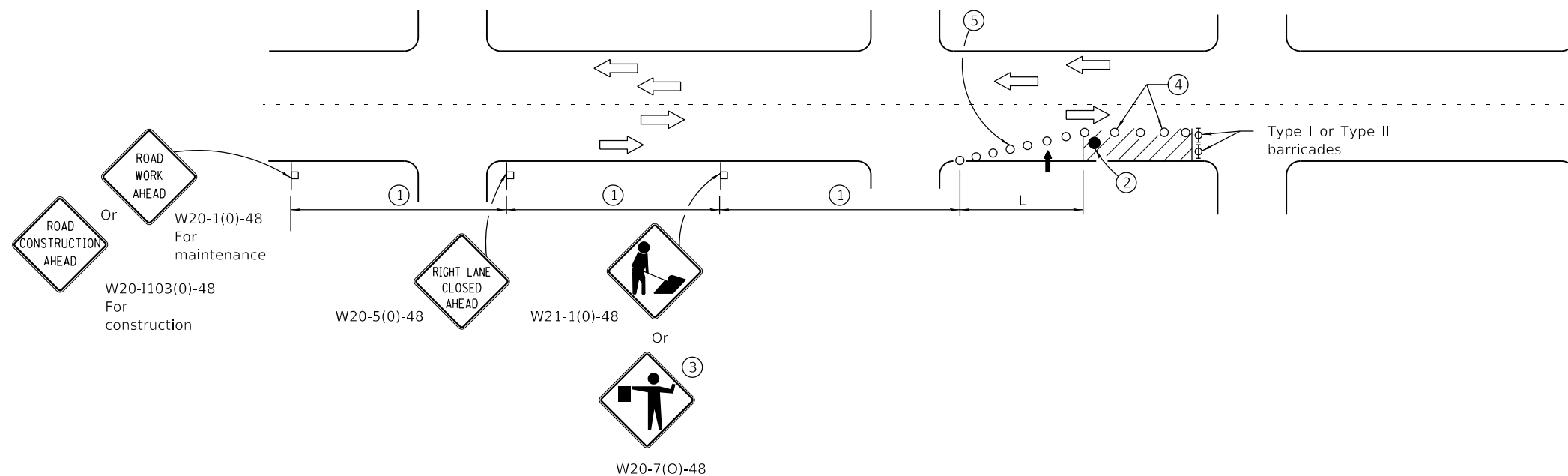

(Sheet 4 of 4)

STANDARD 701602-10



SIGN SPACING	
Posted Speed	Sign Spacing
55	500' (150 m)
50-45	350' (100 m)
<45	200' (60 m)

SYMBOLS

-  Arrow board
-  Cone, drum or barricade
-  Sign on portable or permanent support
-  Work area
-  Barricade or drum with flashing light
-  Flagger with traffic control sign.

- ① Refer to SIGN SPACING TABLE for distances.
- ② Required for speeds > 40 mph.
- ③ Use flagger sign only when flagger is present.
- ④ Cones at 25' (8 m) centers for 250' (75 m). Additional cones may be placed at 50' (15 m) centers. When drums or Type I or Type II barricades are used, the interval between devices may be doubled.
- ⑤ Cones, drums or barricades at 20' (6 m) centers in taper.

GENERAL NOTES

This Standard is used where at any time, day or night, any vehicle, equipment, workers or their activities encroach on the pavement requiring the closure of one traffic lane in an Urban area.

Calculate L as follows:

SPEED LIMIT	FORMULAS	
	English	(Metric)
40 mph (70 km/h) or less:	$L = \frac{WS^2}{60}$	$L = \frac{WS^2}{150}$
45 mph (80 km/h) or greater:	$L = (W)(S)$	$L = 0.65(W)(S)$

W = Width of offset in feet (meters).

S = Normal posted speed mph (km/h).

All dimensions are in inches (millimeters) unless otherwise shown.

DATE	REVISIONS
1-1-15	Renamed standard. Moved case on Sheet 2 to new Highway Standard.
1-1-14	Revised workers sign number to agree with current MUTCD.

URBAN SINGLE LANE CLOSURE, MULTILANE, 2W WITH MOUNTABLE MEDIAN

STANDARD 701606-10

Illinois Department of Transportation

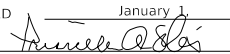
PASSED January 1, 2015

 ENGINEER OF SAFETY ENGINEERING

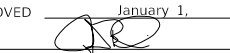
ISSUED 1-1-97

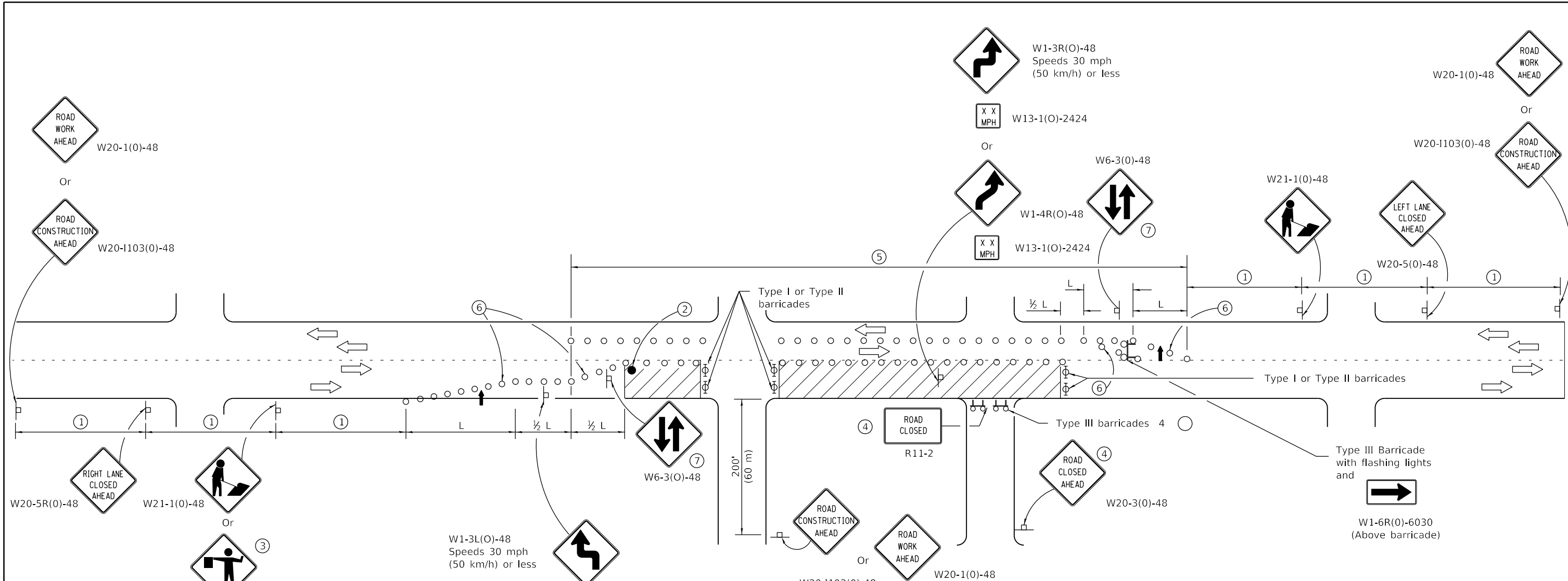
APPROVED January 1, 2015

 ENGINEER OF DESIGN AND ENVIRONMENT



SIGN SPACING	
Posted Speed	Sign Spacing
55	500' (150 m)
50-45	350' (100 m)
<45	200' (60 m)

- W1-3L(O)-48
Speeds 30 mph (50 km/h) or less
- W13-1(O)-2424
- Or
- W1-4L(O)-48
- W13-1(O)-2424

SYMBOLS

- Arrow board
- Cone, drum or barricade
- Sign on portable or permanent support
- Work area
- Barricade or drum with flashing light
- Type III barricade with flashing lights
- Flagger with traffic control sign.

- ① Refer to SIGN SPACING TABLE for distances.
- ② Required for speeds > 40 mph.
- ③ Use flagger sign only when flagger is present.
- ④ For approved sideroad closures.
- ⑤ Cones at 25' (8 m) centers for 250' (75 m). Additional cones may be placed at 50' (15 m) centers. When drums or Type I or Type II barricades are used, the interval between devices may be doubled.
- ⑥ Cones, drums or barricades at 20' (6 m) centers in taper.
- ⑦ Repeat every 1 mile (1.6 km).

GENERAL NOTES

This Standard is used where at any time, day or night, any vehicle, equipment, workers or their activities encroach on the pavement requiring the closure of more than one traffic lane in an Urban area.

Calculate L as follows:

SPEED LIMIT	FORMULAS	
	English	(Metric)
40 mph (70 km/h) or less:	$L = \frac{WS^2}{60}$	$L = \frac{WS^2}{150}$
45 mph (80 km/h) or greater:	$L = (W)(S)$	$L = 0.65(W)(S)$

W = Width of offset in feet (meters).

S = Normal posted speed mph (km/h).

All dimensions are in inches (millimeters) unless otherwise shown.

Illinois Department of Transportation

PASSED April 1, 2016

ENGINEER OF SAFETY ENGINEERING

APPROVED April 1, 2016

ENGINEER OF DESIGN AND ENVIRONMENT

ISSUED 1-1-15

DATE	REVISIONS
4-1-16	Moved first reverse curve/turn sign to middle of tangent.
1-1-15	New Standard.

URBAN HALF ROAD CLOSURE, MULTILANE, 2W WITH MOUNTABLE MEDIAN

STANDARD 701611-01

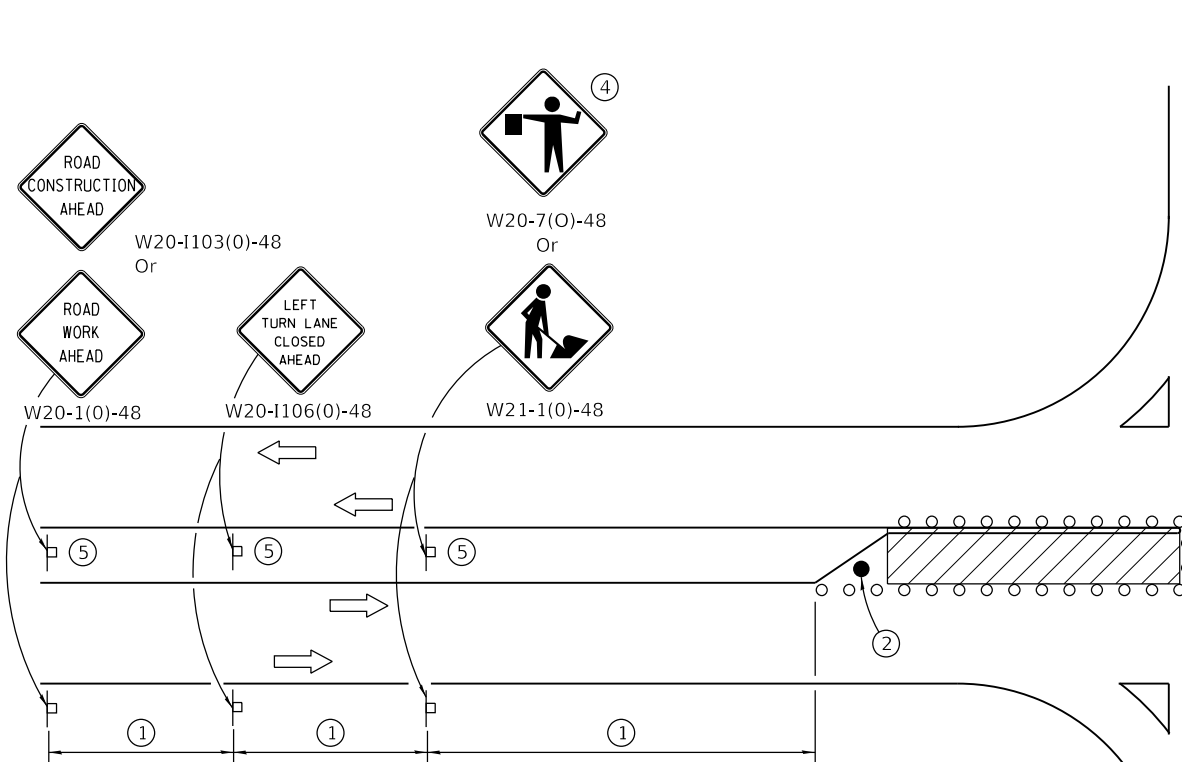

LEFT TURN LANE OR CENTER MEDIAN OPERATIONS

- ① Refer to SIGN SPACING TABLE for distance.
- ② Required for speed > 40 mph.
- ③ Cones at 25' (8 m) centers for 250' (75 m). Additional cones may be placed at 50' (15 m) centers. When drums or Type I or Type II barricades are used, the interval between devices may be doubled.
- ④ Use flagger sign only when flagger is present.
- ⑤ Omit this sign when median is less than 10' (3 m) or for bi-directional turn lanes.
- ⑥ Cones, drums or barricades at 20' (6 m) centers in taper.
- ⑦ Advanced arrow board required for speeds > 45 mph.
- ⑧ Three Type II barricades, drums or vertical barricades at 50' (15 m) centers.

SIGN SPACING	
Posted Speed	Sign Spacing
55	500' (150 m)
50-45	350' (100 m)
<45	200' (60 m)

SYMBOLS

- Work area
- Cone, drum or barricade
- Sign on portable or permanent support
- Arrow board
- Barricade or drum with flashing light
- Flagger with traffic control sign

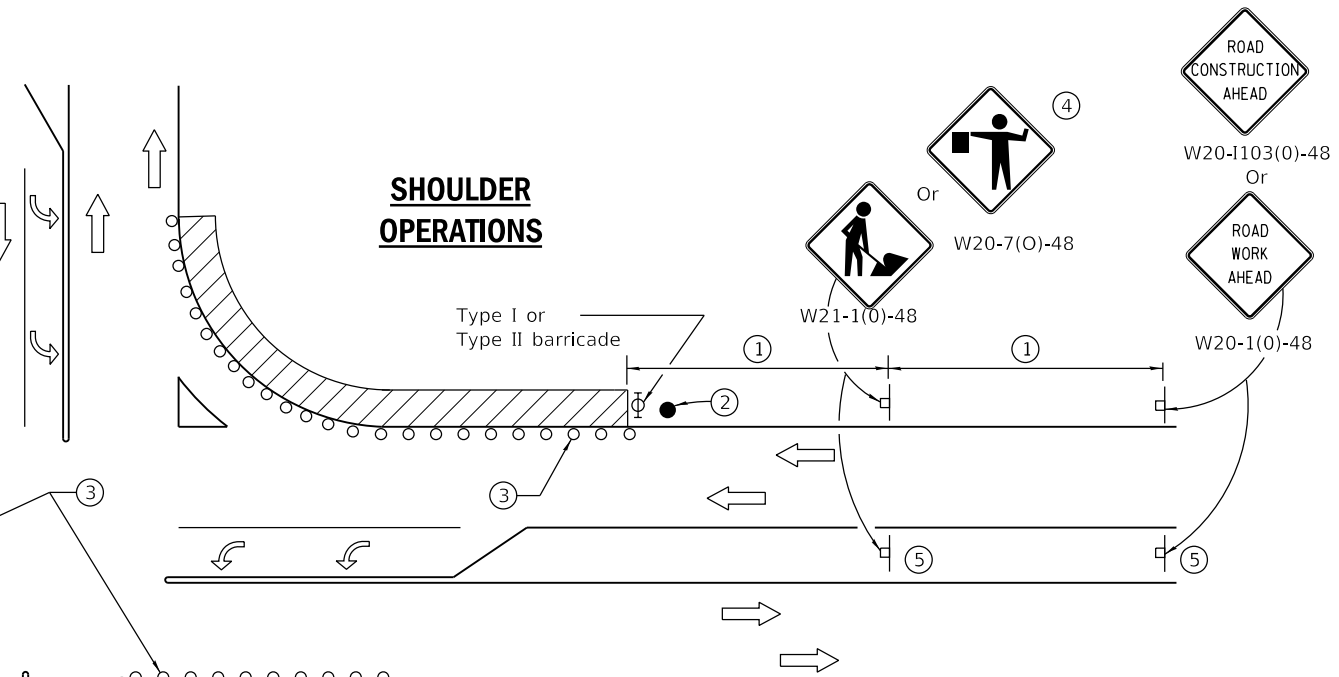

SHOULDER OPERATIONS

CORNER ISLAND OPERATIONS

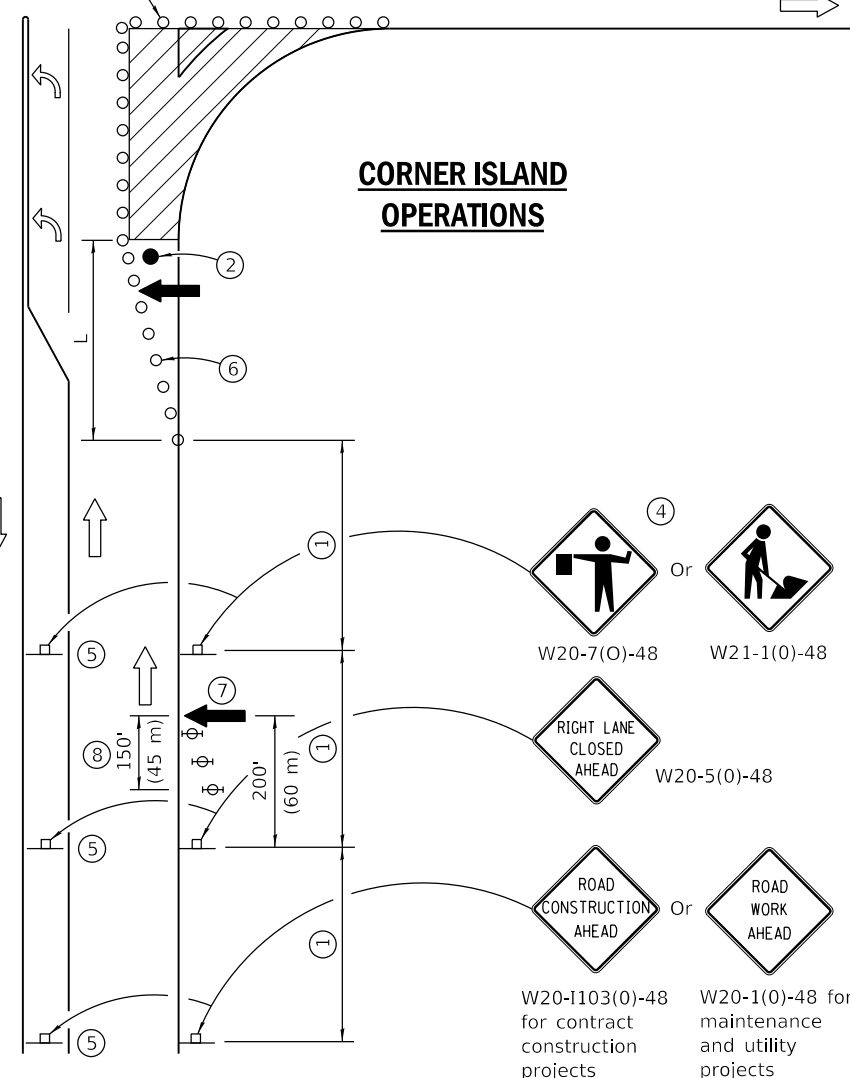

GENERAL NOTES

This Standard is used where at any time, day or night, any vehicle, equipment, workers or their activities encroach on the pavement during shoulder operations or where construction requires lane closures in an urban area.

Calculate L as follows:

SPEED LIMIT	FORMULAS	
	English	(Metric)
40 mph (70 km/h) or less:	$L = \frac{WS^2}{60}$	$L = \frac{WS^2}{150}$
45 mph (80 km/h) or greater:	$L = (W)(S)$	$L = 0.65(W)(S)$

W = Width of offset in feet (meters).

S = Normal posted speed mph (km/h).

All dimensions are in inches (millimeters) unless otherwise shown.

DATE	REVISIONS
4-1-16	Corrected sign number for LEFT TURN LANE CLOSED AHEAD.
1-1-14	Added devices at arrow board upstream from taper.
	Rev. workers sign number.

URBAN LANE CLOSURE, MULTILANE INTERSECTION

STANDARD 701701-10

Illinois Department of Transportation

PASSED April 1, 2016

[Signature]
ENGINEER OF SAFETY ENGINEERING

APPROVED April 1, 2016

[Signature]
ENGINEER OF DESIGN AND ENVIRONMENT

ISSUED 1-1-97

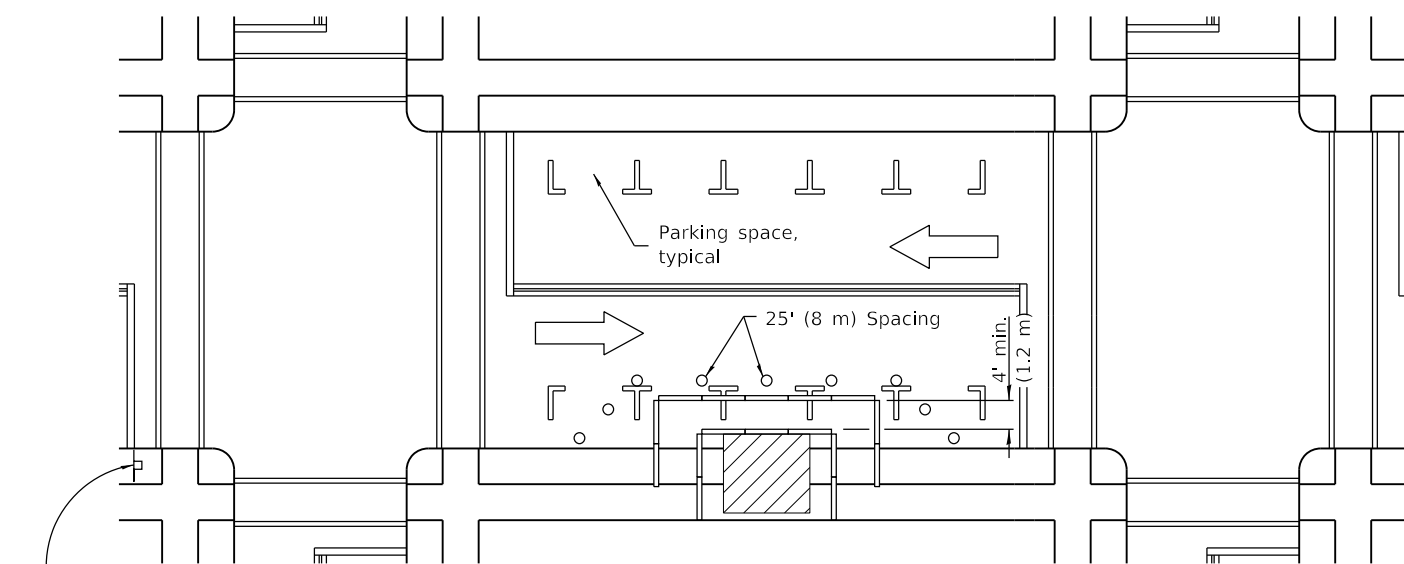

① ROAD CONSTRUCTION AHEAD
W20-1103(0)-48 for contract construction projects

Or
① ROAD WORK AHEAD
W20-1(0)-48 for maintenance and utility projects

SIDEWALK DIVERSION

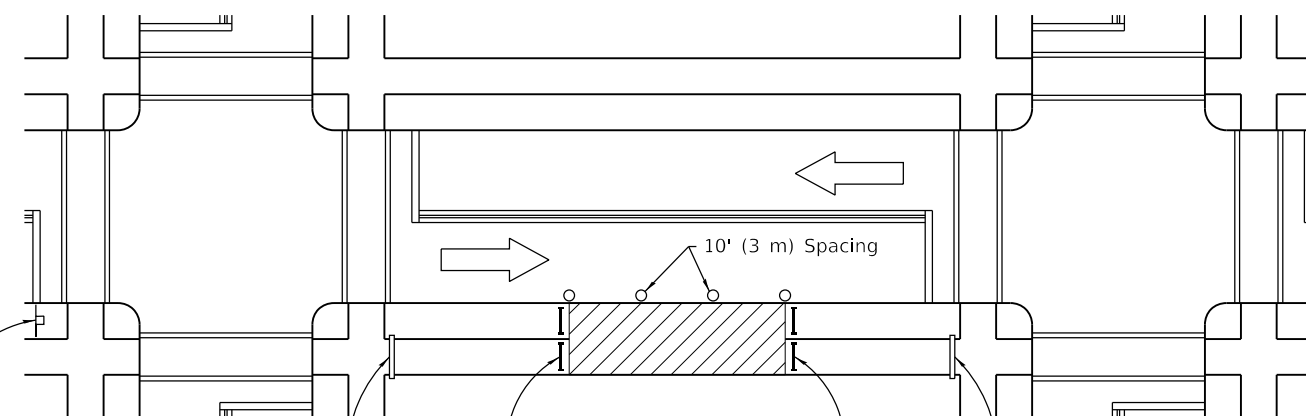

① ROAD CONSTRUCTION AHEAD
W20-1103(0)-48 for contract construction projects

Or
① ROAD WORK AHEAD
W20-1(0)-48 for maintenance and utility projects







SIDEWALK CLOSED
←
USE OTHER SIDE
R11-1102-2430

SIDEWALK CLOSED
R11-1101-2418

SIDEWALK CLOSED
→
USE OTHER SIDE
R11-1102-2430

SIDEWALK CLOSURE

SYMBOLS

-  Work area
-  Sign on portable or permanent support
-  Barricade or drum
-  Cone, drum or barricade
-  Type III barricade
-  Detectable pedestrian channelizing barricade

① Omit whenever duplicated by road work traffic control.

GENERAL NOTES

This Standard is used where, at any time, pedestrian traffic must be rerouted due to work being performed.

This Standard must be used in conjunction with other Traffic Control & Protection Standards when roadway traffic is affected.

Temporary facilities shall be detectable and accessible.

The temporary pedestrian facilities shall be provided on the same side of the closed facilities whenever possible.

The SIDEWALK CLOSED / USE OTHER SIDE sign shall be placed at the nearest crosswalk or intersection to each end of the closure. Where the closure occurs at a corner, the signs shall be erected on the corners across the street from the closure. The SIDEWALK CLOSED signs shall be used at the ends of the actual closures.

Type III barricades and R11-2-4830 signs shall be positioned as shown in "ROAD CLOSED TO ALL TRAFFIC" detail on Standard 701901.

All dimensions are in inches (millimeters) unless otherwise shown.

DATE	REVISIONS
4-1-16	Omitted orange safety fence from standard as this is covered in the std. spec.
1-1-12	Added SIDEWALK DIVERSION. Modified appearance of plan views. Renamed Std.

SIDEWALK, CORNER OR CROSSWALK CLOSURE

(Sheet 1 of 2)

STANDARD 701801-06

Illinois Department of Transportation

PASSED April 1, 2016

[Signature]
ENGINEER OF SAFETY ENGINEERING

APPROVED April 1, 2016

[Signature]
ENGINEER OF DESIGN AND ENVIRONMENT

ISSUED 1-1-97

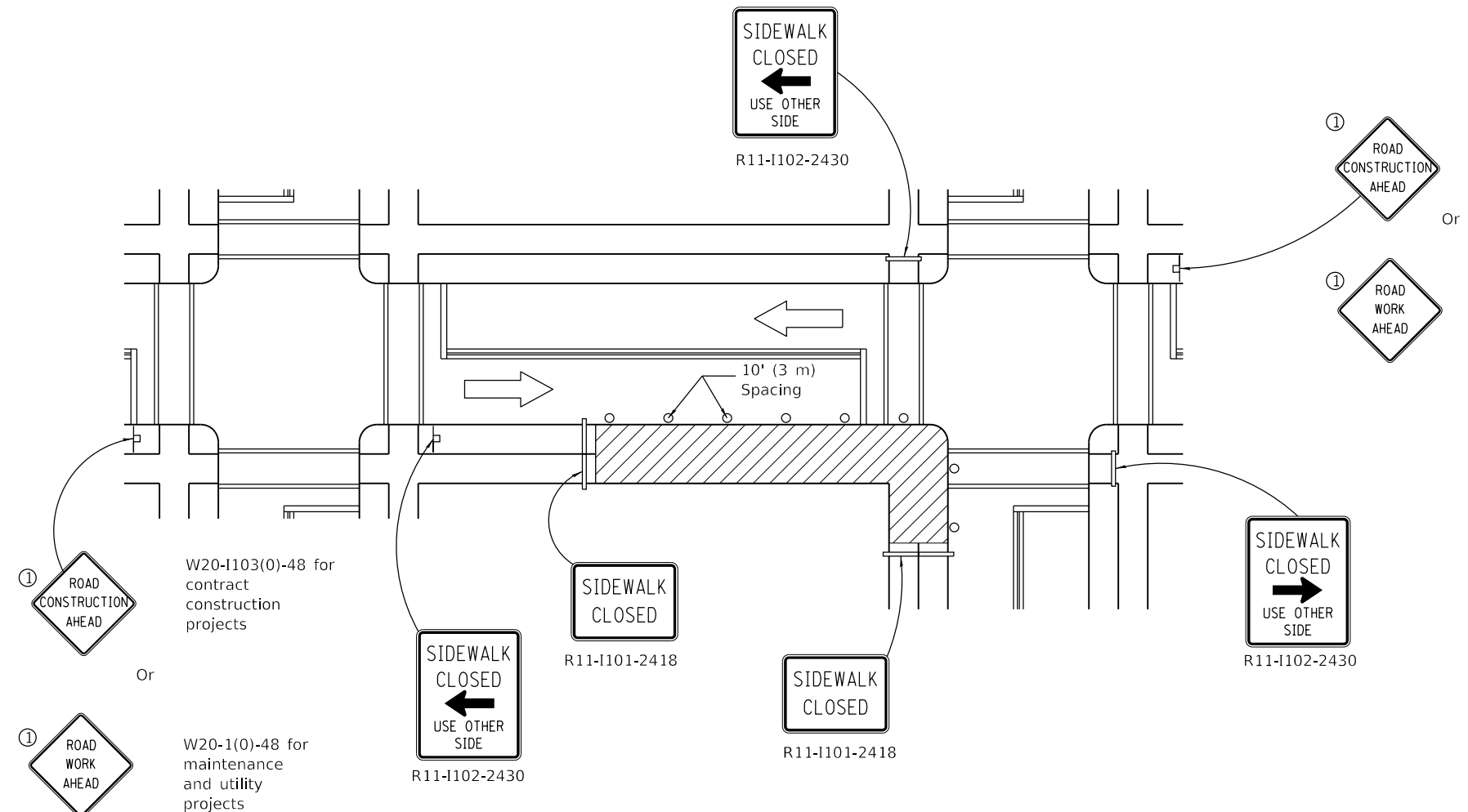

CORNER CLOSURE

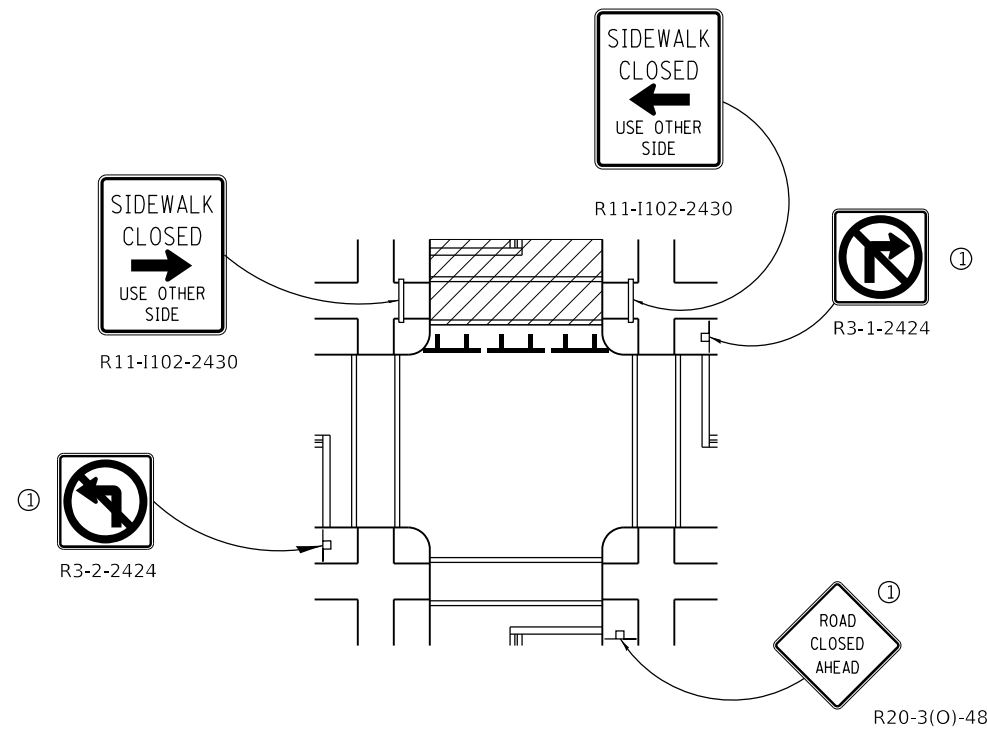

CROSSWALK CLOSURE

W20-I103(0)-48 for contract construction projects

Or

W20-1(0)-48 for maintenance and utility projects

SIDEWALK, CORNER OR CROSSWALK CLOSURE

(Sheet 2 of 2)

STANDARD 701801-06

Illinois Department of Transportation

PASSED April 1, 2016

[Signature]
ENGINEER OF SAFETY ENGINEERING

APPROVED April 1, 2016

[Signature]
ENGINEER OF DESIGN AND ENVIRONMENT

ISSUED 1-1-97

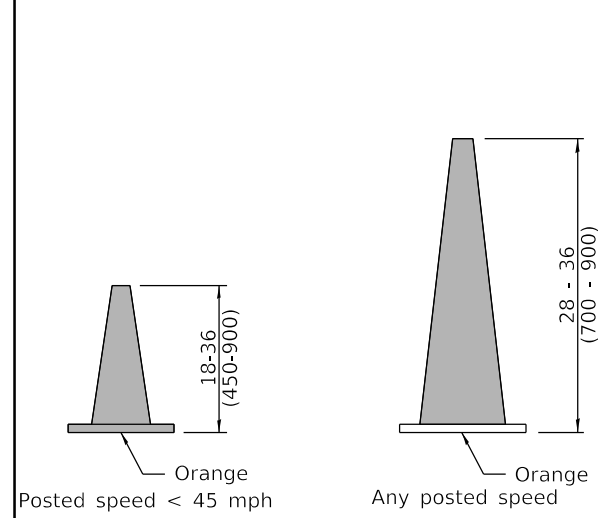

DAYTIME USE

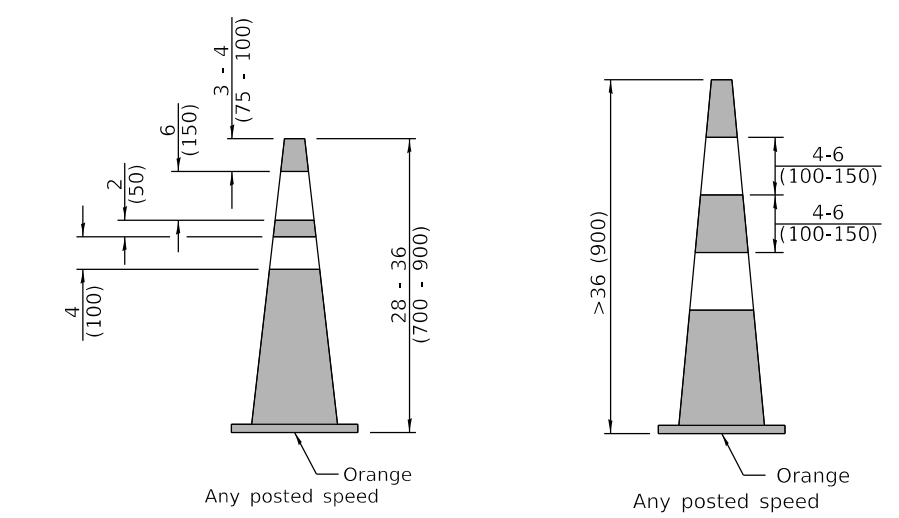

DAY OR NIGHTTIME USE

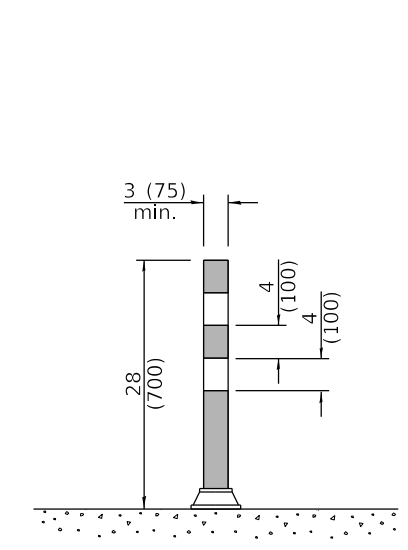

TUBULAR MARKER

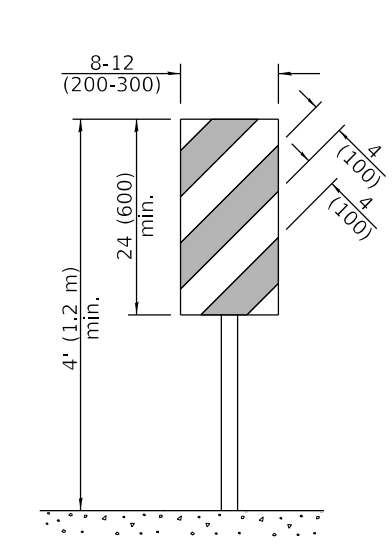

**VERTICAL PANEL
POST MOUNTED**

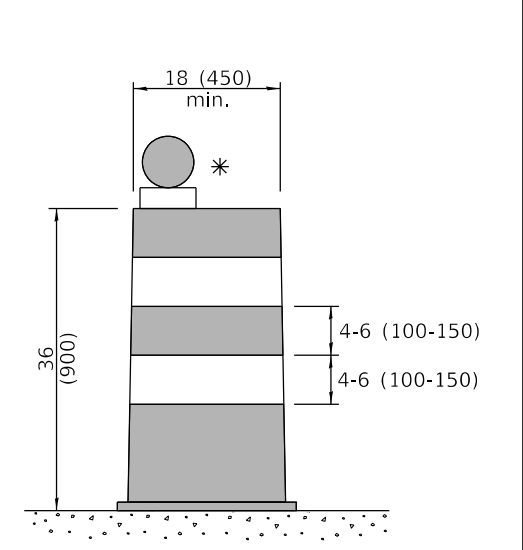

DRUM

CONES

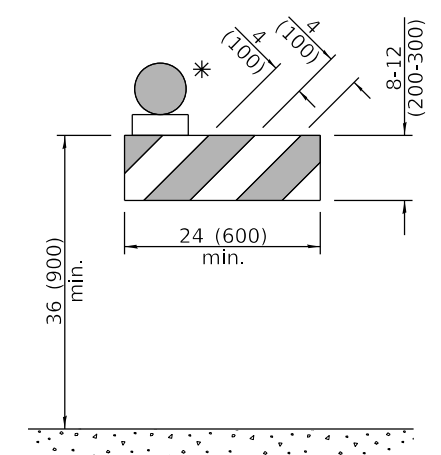

TYPE I BARRICADE

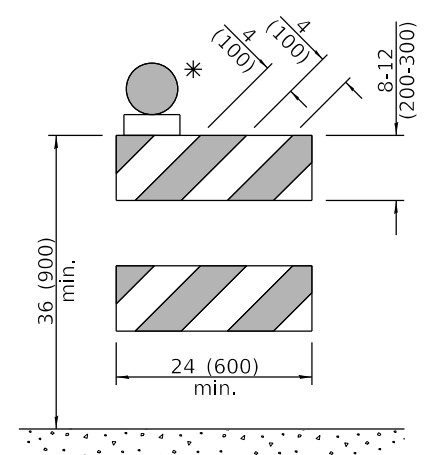

TYPE II BARRICADE

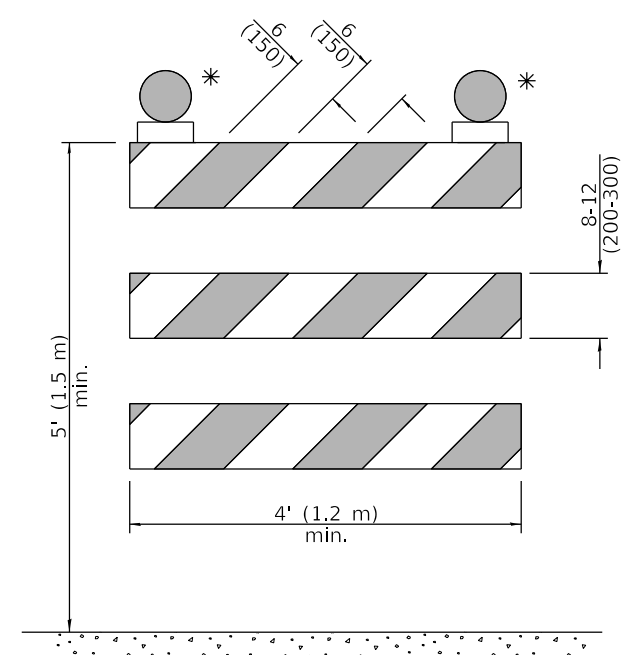

TYPE III BARRICADE

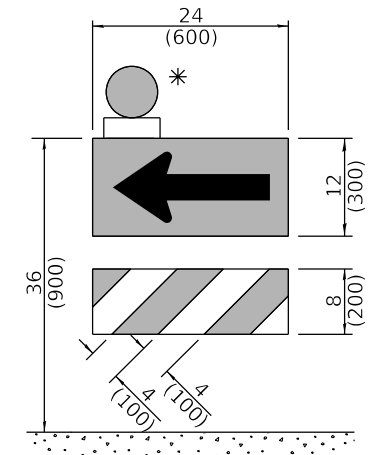

**DIRECTION INDICATOR
BARRICADE**

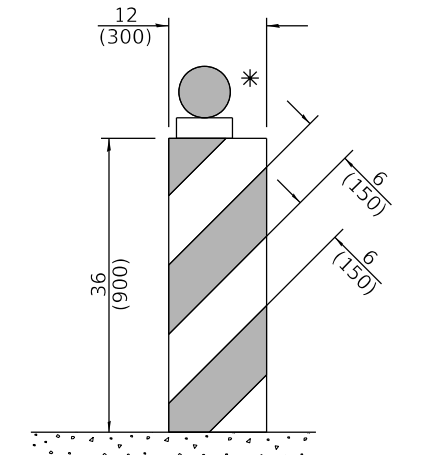

VERTICAL BARRICADE

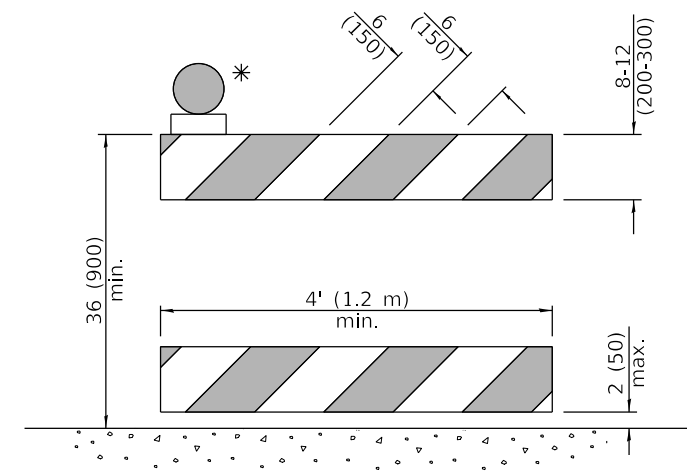

**DETECTABLE PEDESTRIAN
CHANNELIZING BARRICADE**

* Warning lights (if required)

GENERAL NOTES

All heights shown shall be measured above the pavement surface.
All dimensions are in inches (millimeters) unless otherwise shown.

Illinois Department of Transportation

APPROVED January 1, 2019
Cynthia Watt
ENGINEER OF SAFETY PROG. AND ENGINEERING

APPROVED January 1, 2019
Joe E. ...
ENGINEER OF DESIGN AND ENVIRONMENT

ISSUED
E1-1-1

DATE	REVISIONS
1-1-19	Revised cone usage and added cones >36" (900 mm) height.
1-1-18	Revised END WORK ZONE SPEED LIMIT sign from orange to white background.

TRAFFIC CONTROL DEVICES

(Sheet 1 of 3)

STANDARD 701901-08

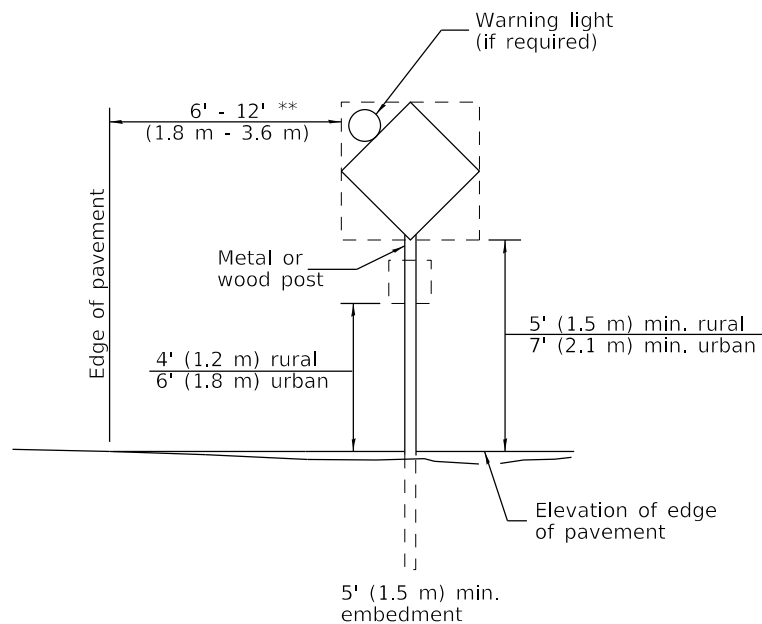

POST MOUNTED SIGNS

** When curb or paved shoulder are present this dimension shall be 24 (600) to the face of curb or 6' (1.8 m) to the outside edge of the paved shoulder.

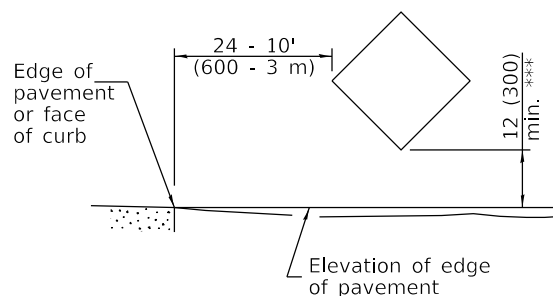

SIGNS ON TEMPORARY SUPPORTS

*** When work operations exceed four days, this dimension shall be 5' (1.5 m) min. If located behind other devices, the height shall be sufficient to be seen completely above the devices.

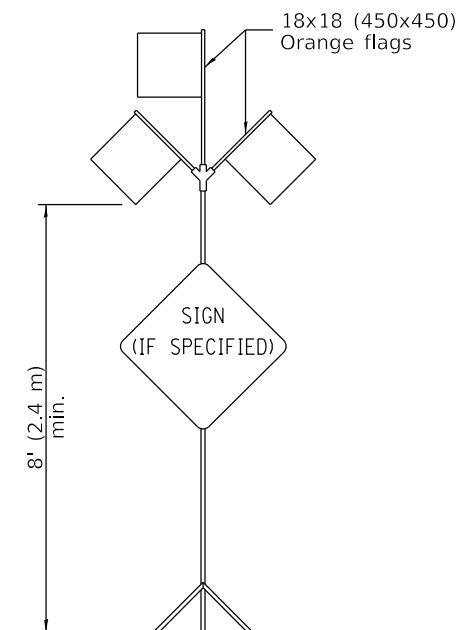

HIGH LEVEL WARNING DEVICE

ROAD CONSTRUCTION NEXT X MILES

G20-I104(0)-6036

END CONSTRUCTION

G20-I105(0)-6024

This signing is required for all projects 2 miles (3200 m) or more in length.

ROAD CONSTRUCTION NEXT X MILES sign shall be placed 500' (150 m) in advance of project limits.

END CONSTRUCTION sign shall be erected at the end of the job unless another job is within 2 miles (3200 m).

Dual sign displays shall be utilized on multi-lane highways.

WORK LIMIT SIGNING

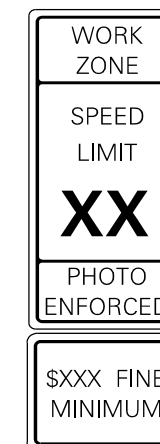

W21-III5(0)-3618

R2-1-3648

R10-I108p-3618 ****

R2-I106p-3618

Sign assembly as shown on Standards or as allowed by District Operations.

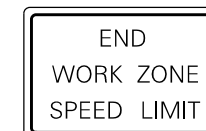

G20-I103-6036

This sign shall be used when the above sign assembly is used.

HIGHWAY CONSTRUCTION SPEED ZONE SIGNS

**** R10-I108p shall only be used along roadways under the jurisdiction of the State.

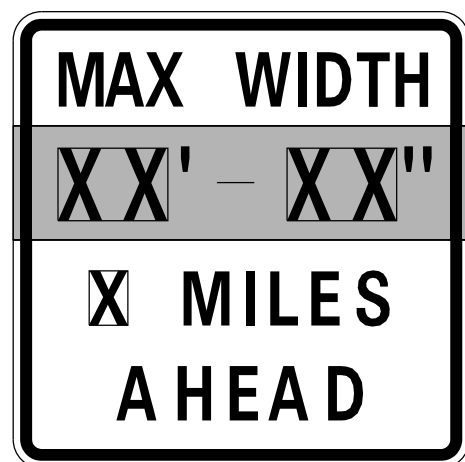

W12-I103-4848

WIDTH RESTRICTION SIGN

XX'-XX" width and X miles are variable.

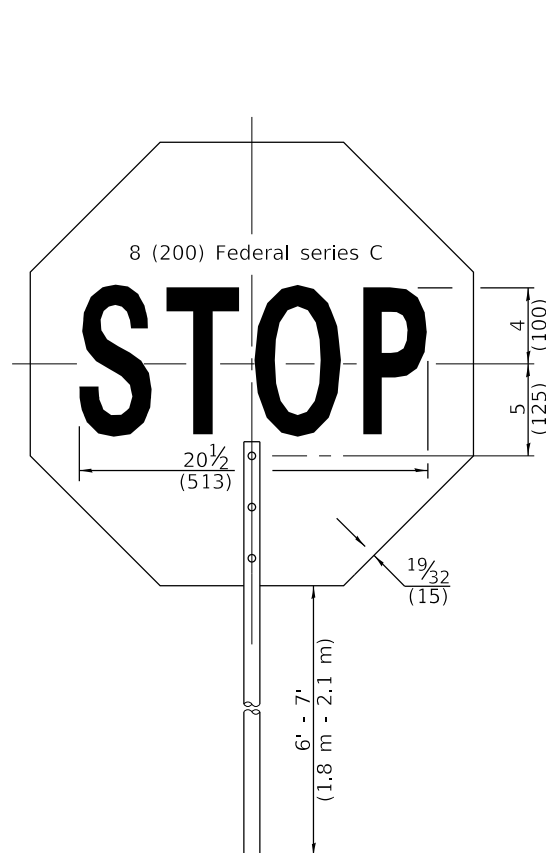

FRONT SIDE

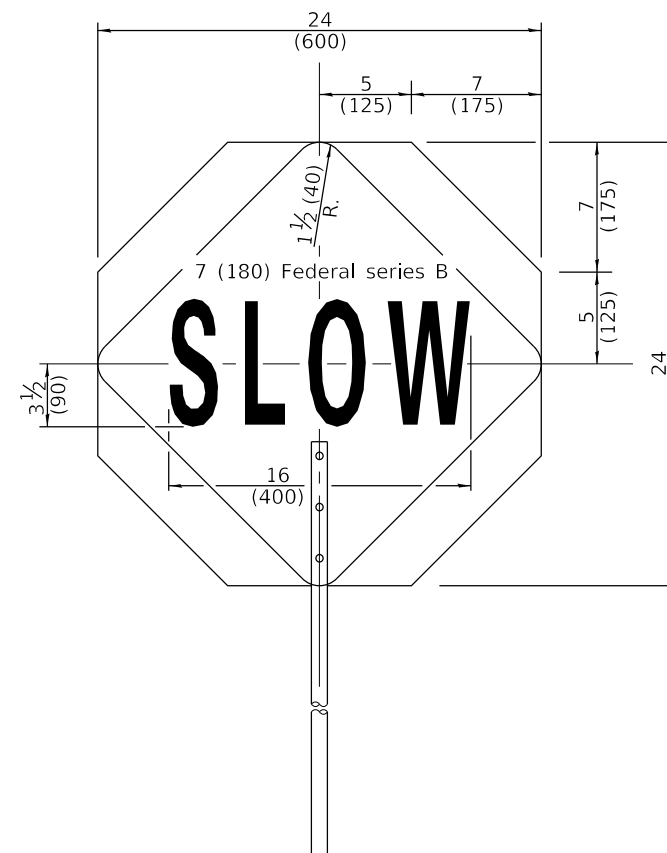

REVERSE SIDE

FLAGGER TRAFFIC CONTROL SIGN

Illinois Department of Transportation

APPROVED January 1, 2019
Cynthia Watt
 ENGINEER OF SAFETY PROG. AND ENGINEERING

APPROVED January 1, 2019
John E. ...
 ENGINEER OF DESIGN AND ENVIRONMENT

ISSUED 1-1-13

TRAFFIC CONTROL DEVICES

(Sheet 2 of 3)

STANDARD 701901-08

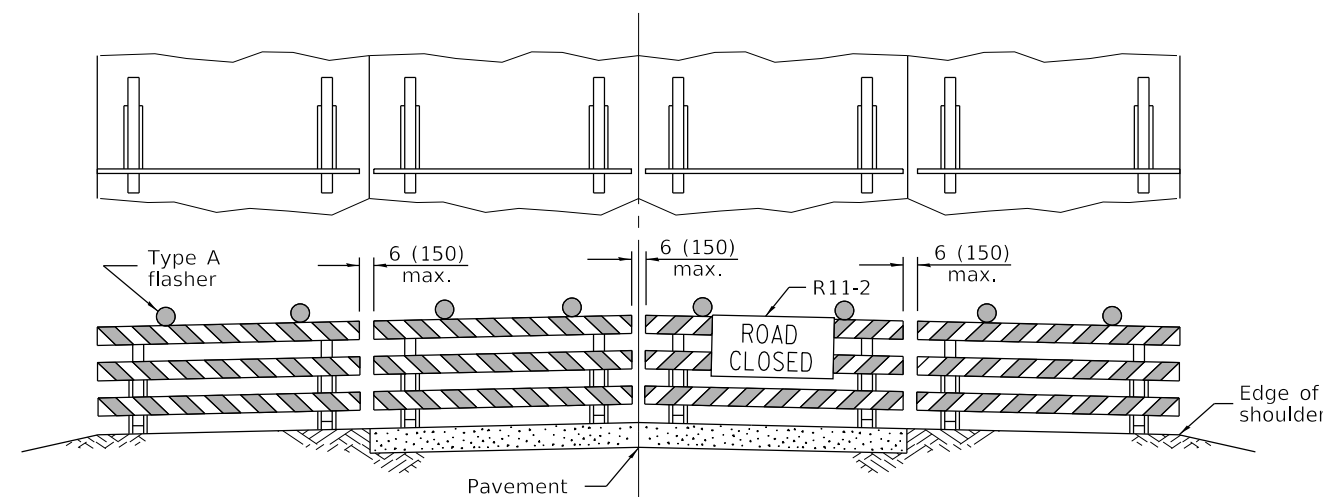
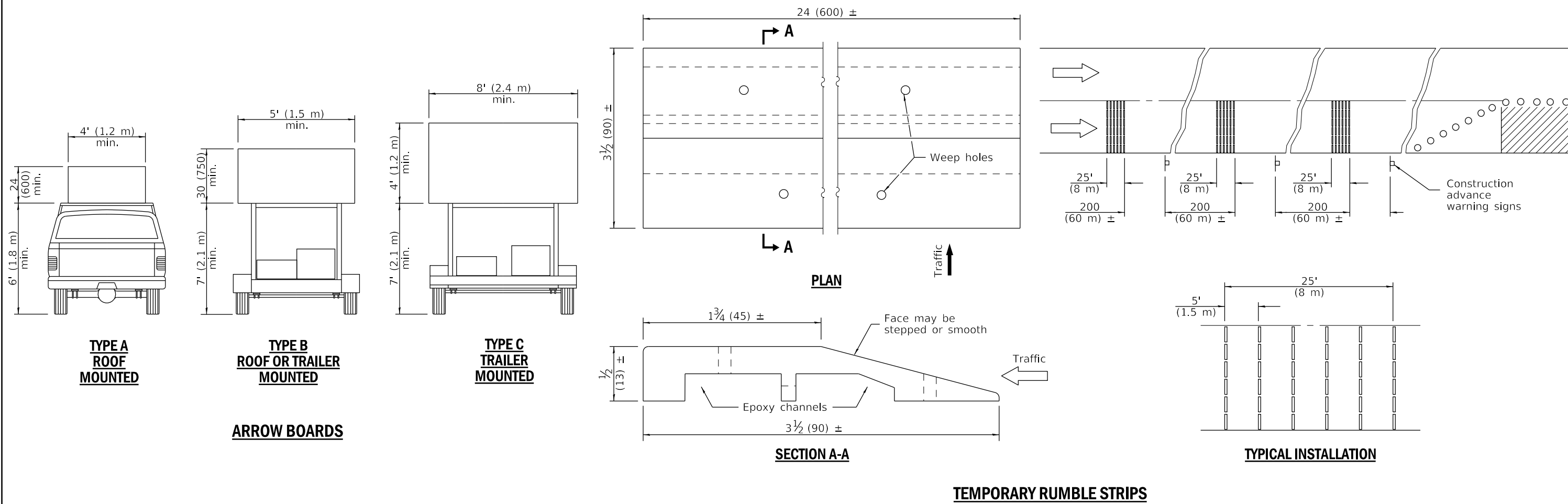

Reflectorized striping may be omitted on the back side of the barricades. If a Type III barricade with an attached sign panel which meets NCHRP 350 is not available, the sign may be mounted on an NCHRP 350 temporary sign support directly in front of the barricade.

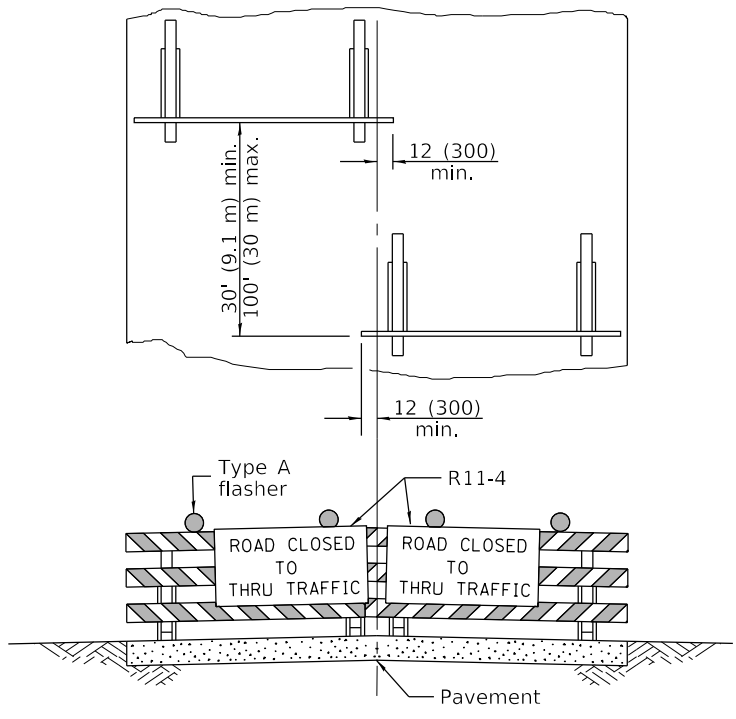

Reflectorized striping shall appear on both sides of the barricades. If a Type III barricade with an attached sign panel which meets NCHRP 350 is not available, the signs may be mounted on NCHRP 350 temporary sign supports directly in front of the barricade.

TYPICAL APPLICATIONS OF TYPE III BARRICADES CLOSING A ROAD

TRAFFIC CONTROL DEVICES

(Sheet 3 of 3)

STANDARD 701901-08

Illinois Department of Transportation

APPROVED January 1, 2019
Cynthia Watt
 ENGINEER OF SAFETY PROG. AND ENGINEERING

APPROVED January 1, 2019
Joe E. ...
 ENGINEER OF DESIGN AND ENVIRONMENT

ISSUES: E1-1-1 Q8US81

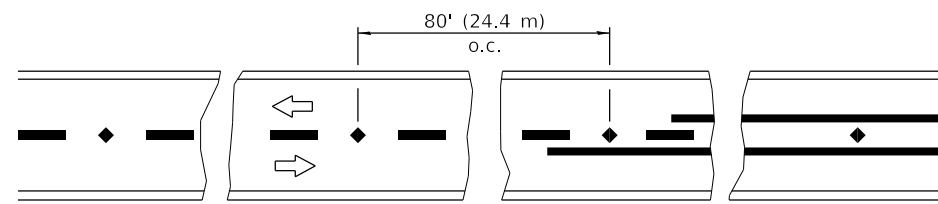

Reduce to 40' (12.2 m) o.c. on curves with posted or advisory speeds of 45 mph (70 km/h) or less.

TWO-LANE / TWO-WAY

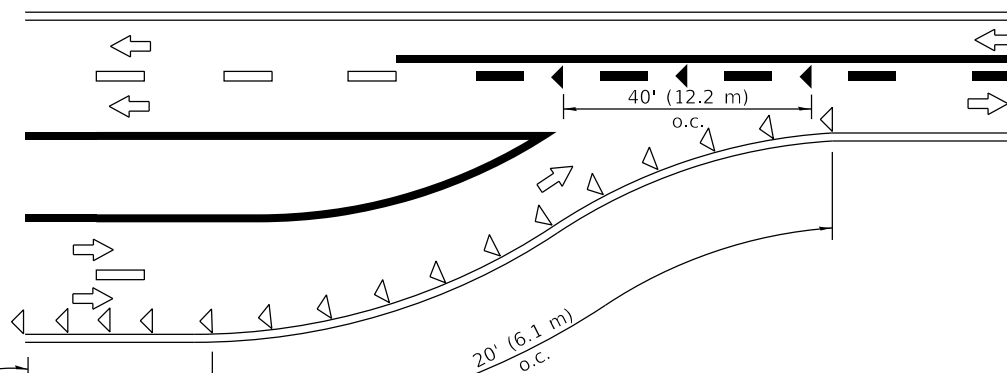

W4-2

LANE REDUCTION TRANSITION

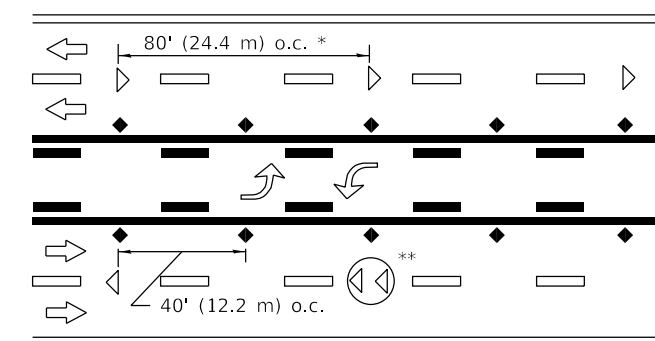

*,** See MULTI LANE DIVIDED detail for lane marker notes.

TWO-WAY LEFT TURN

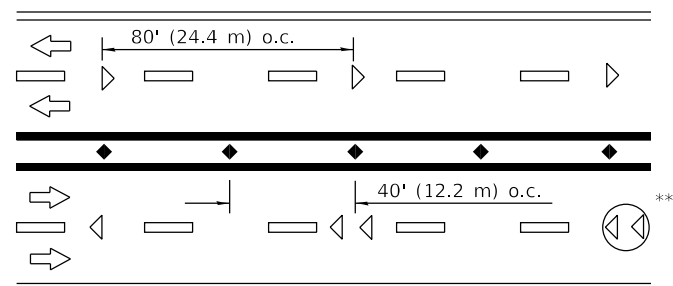

*,** See MULTI LANE DIVIDED detail for lane marker notes.

MULTI-LANE UNDIVIDED

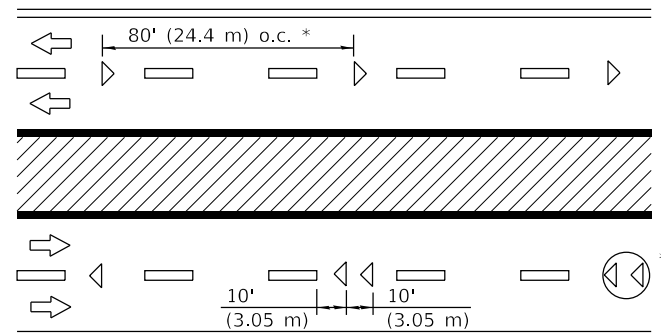

* Reduce to 40' (12.2 m) o.c. on curves where advisory speeds are 10 mph (15 km/h) lower than posted speeds.

** Where double lane line markers are specified, they shall be spaced as shown.

MULTI-LANE DIVIDED

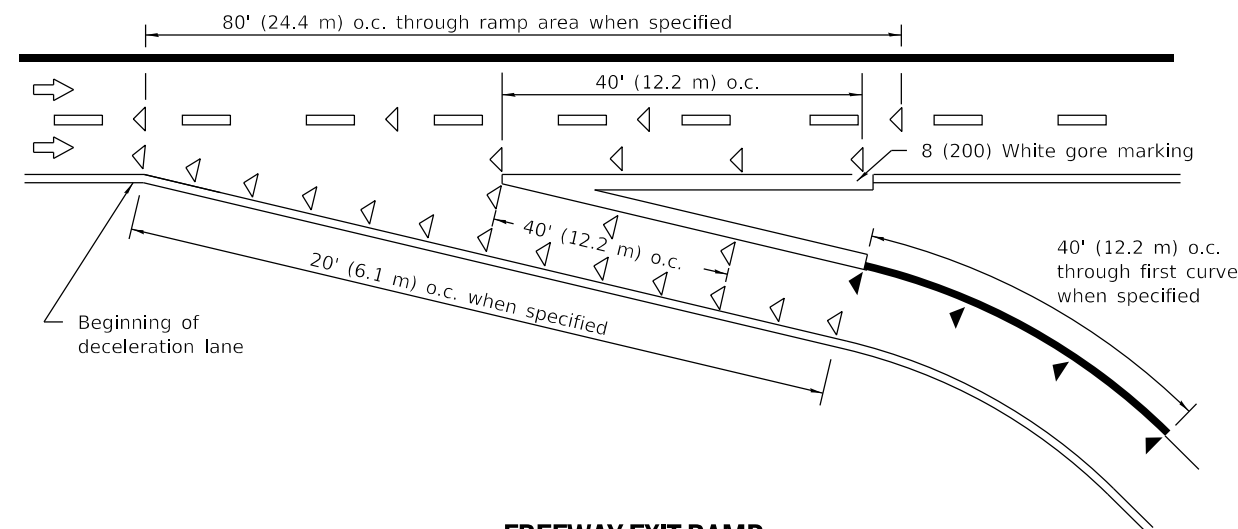

FREEWAY EXIT RAMP

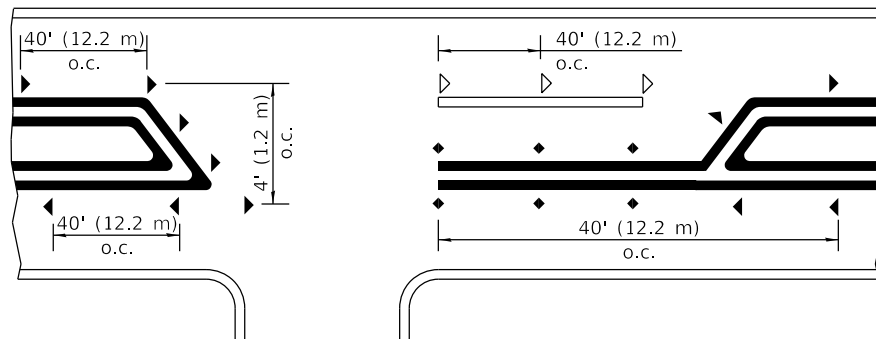
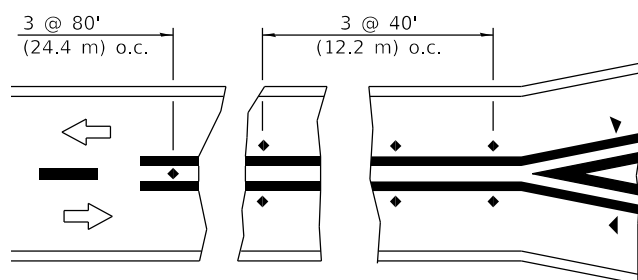

RURAL LEFT TURN

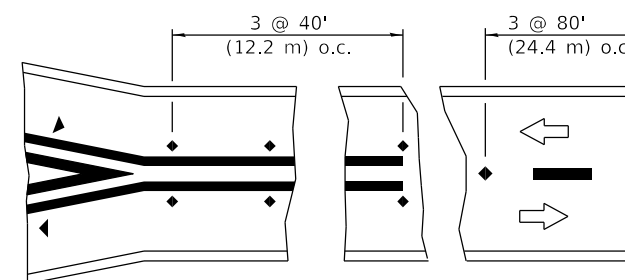

SYMBOLS

- Yellow stripe
- White stripe
- One-way amber marker
- One-way crystal marker
- Two-way amber marker

All dimensions are in inches (millimeters) unless otherwise shown.

**TYPICAL APPLICATIONS
RAISED REFLECTIVE
PAVEMENT MARKERS**

STANDARD 781001-04

Illinois Department of Transportation

PASSED April 1, 2016
Amy Eller
 ENGINEER OF OPERATIONS

APPROVED April 1, 2016
[Signature]
 ENGINEER OF DESIGN AND ENVIRONMENT

ISSUED 1-1-97

DATE	REVISIONS
4-1-16	Revised LANE ENDS sign
	W4-2 to agree with current MUTCD.
1-1-09	Switched units to English (metric).

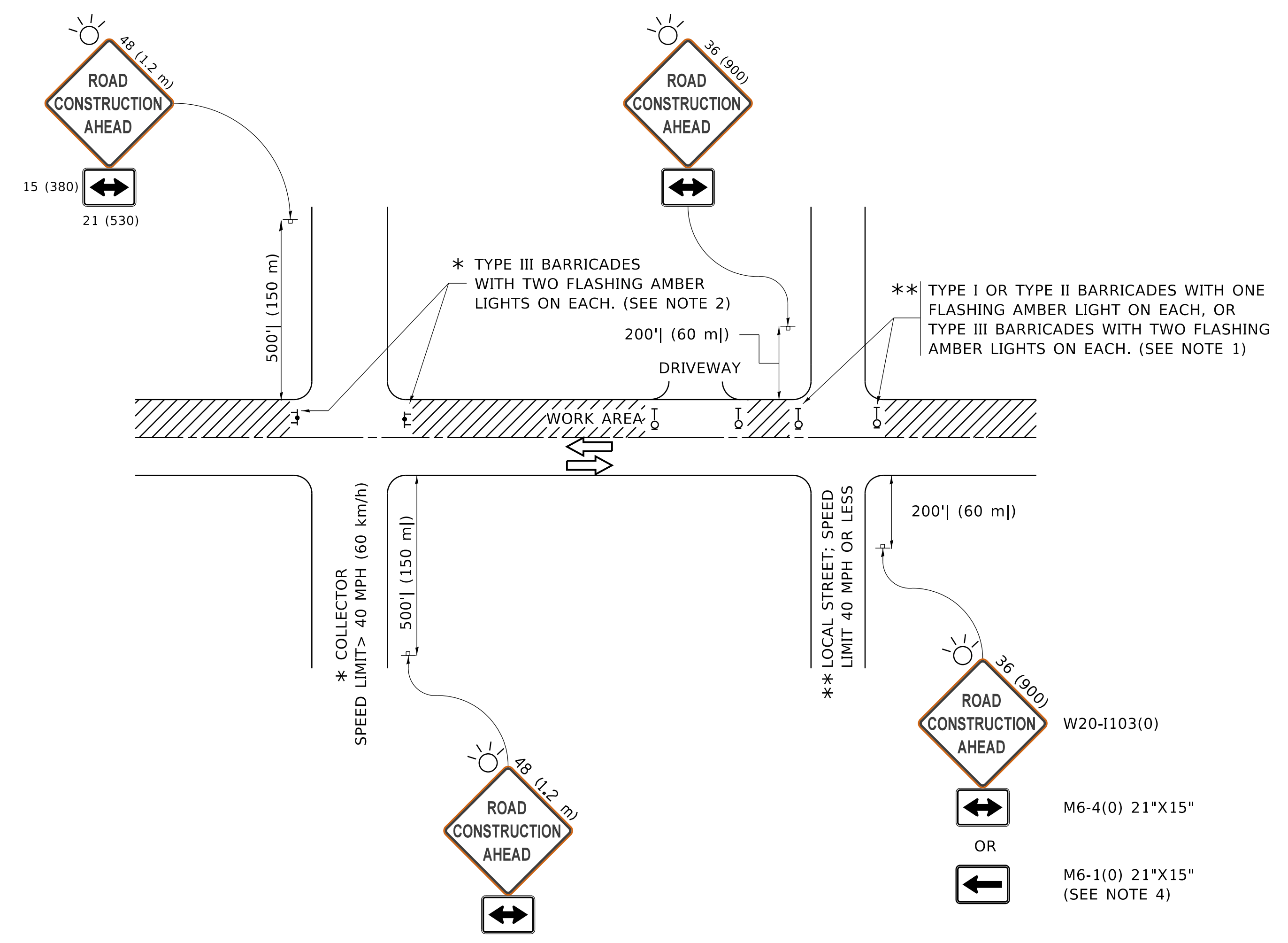

NOTES:

- SIDE ROAD WITH A SPEED LIMIT OF 40 MPH (60 km/h) OR LESS AS SHOWN ON THE DRAWING AND AS DIRECTED BY THE ENGINEER:
 - ONE "ROAD CONSTRUCTION AHEAD" SIGN 36 x 36 (900x900) WITH A FLASHER MOUNTED ON IT APPROXIMATELY 200' (60 m) IN ADVANCE OF THE MAIN ROUTE.
 - THE CLOSED PORTION OF THE MAIN ROUTE SHALL BE PROTECTED BY BLOCKING WITH TYPE I, TYPE II OR TYPE III BARRICADES, 1/3 OF THE CROSS SECTION OF THE CLOSED PORTION.
 - SIDE ROAD WITH A SPEED LIMIT GREATER THAN 40 MPH (60 km/h) AS SHOWN ON THE DRAWING AND AS DIRECTED BY THE ENGINEER:
 - ONE "ROAD CONSTRUCTION AHEAD" SIGN 48 x 48 (1.2 m x 1.2 m) WITH A FLASHER MOUNTED ON IT APPROXIMATELY 500' (150 m) IN ADVANCE OF THE MAIN ROUTE.
 - THE CLOSED PORTION OF THE MAIN ROUTE SHALL BE PROTECTED BY BLOCKING WITH TYPE III BARRICADES, 1/2 OF THE CROSS SECTION OF THE CLOSED PORTION.
 - CONES MAY BE SUBSTITUTED FOR BARRICADES OR DRUMS AT HALF THE SPACING DURING DAY OPERATIONS. CONES SHALL BE A MINIMUM OF 28 (710) IN HEIGHT.
 - SIGNING AND THE WORK ZONE, A SINGLE HEADED ARROW (M6-1) SHALL BE USED IN LIEU OF THE DOUBLE HEADED ARROW (M6-4).
- WHEN THE SIDE ROAD LIES BETWEEN THE BEGINNING OF THE MAINLINE AND THE WORK ZONE, A SINGLE HEADED ARROW (M6-1) SHALL BE USED IN LIEU OF THE DOUBLE HEADED ARROW (M6-4).
 - WHEN WORK IS BEING PERFORMED ON A SIDE ROAD OR DRIVEWAY, FOLLOW THE APPLICABLE STANDARD(S). THE DIRECTIONAL ARROW (M6-1 OR M6-4) SHALL BE COVERED OR REMOVED WHEN NO LONGER CONSISTENT WITH THE TRAFFIC CONTROL SET-UP.
 - ADVANCE WARNING SIGNS ARE TO BE OMITTED ON DRIVEWAYS UNLESS OTHERWISE SPECIFIED IN THE PLANS OR BY THE ENGINEER.
 - THE TRAFFIC CONTROL AND PROTECTION FOR SIDE ROADS, INTERSECTIONS, AND DRIVEWAYS SHALL BE INCLUDED IN THE COST OF SPECIFIED TRAFFIC CONTROL STANDARDS OR ITEMS.

All dimensions are in inches (millimeters) unless otherwise shown.

MODEL: Default
FILE NAME: p:\1108\EBID\NTEG\Illinois.gov\PIWDOT\Documents\DOT_Offices\District_1\Projects\DHHS\22-23\CADData\CAD\sheet\10.dgn

USER NAME = footemj	DESIGNED - L.H.A.	REVISED - A. HOUSEH 10-15-96
	DRAWN -	REVISED - T. RAMMACHER 01-06-00
PLOT SCALE = 50.0000 ' / in.	CHECKED -	REVISED - A. SCHUETZE 07-01-13
PLOT DATE = 3/4/2019	DATE - 06-89	REVISED - A. SCHUETZE 09-15-16

**STATE OF ILLINOIS
DEPARTMENT OF TRANSPORTATION**

**TRAFFIC CONTROL AND PROTECTION FOR
SIDE ROADS, INTERSECTIONS, AND DRIVEWAYS**

SCALE: NONE SHEET 1 OF 1 SHEETS STA. TO STA.

F.A. RTE.	SECTION	COUNTY	TOTAL SHEETS	SHEET NO.
	TC-10			
		CONTRACT NO.		
		ILLINOIS FED. AID PROJECT		

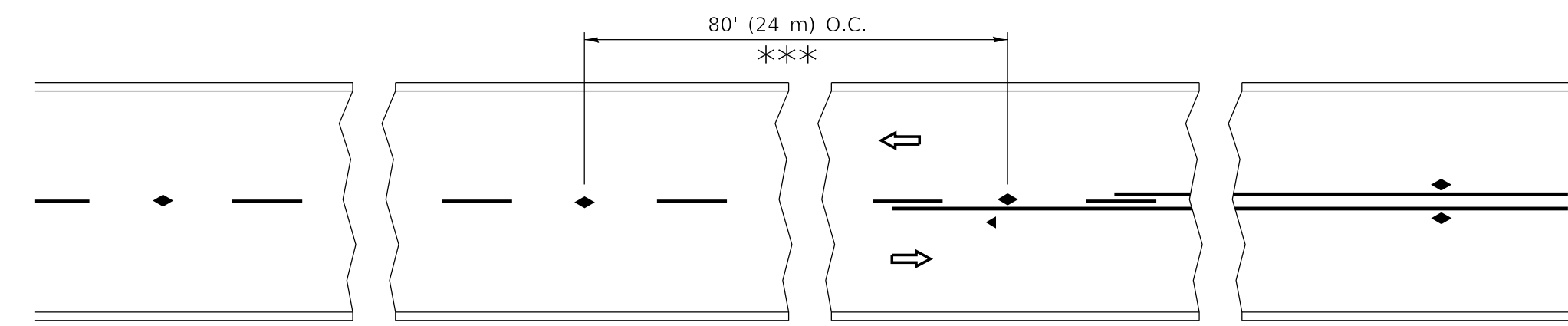

*** REDUCE TO 40' (12 m) O.C. ON CURVES WITH POSTED OR ADVISORY SPEED 45 M.P.H. (70 km/h) OR LESS.

TWO-LANE/TWO-WAY

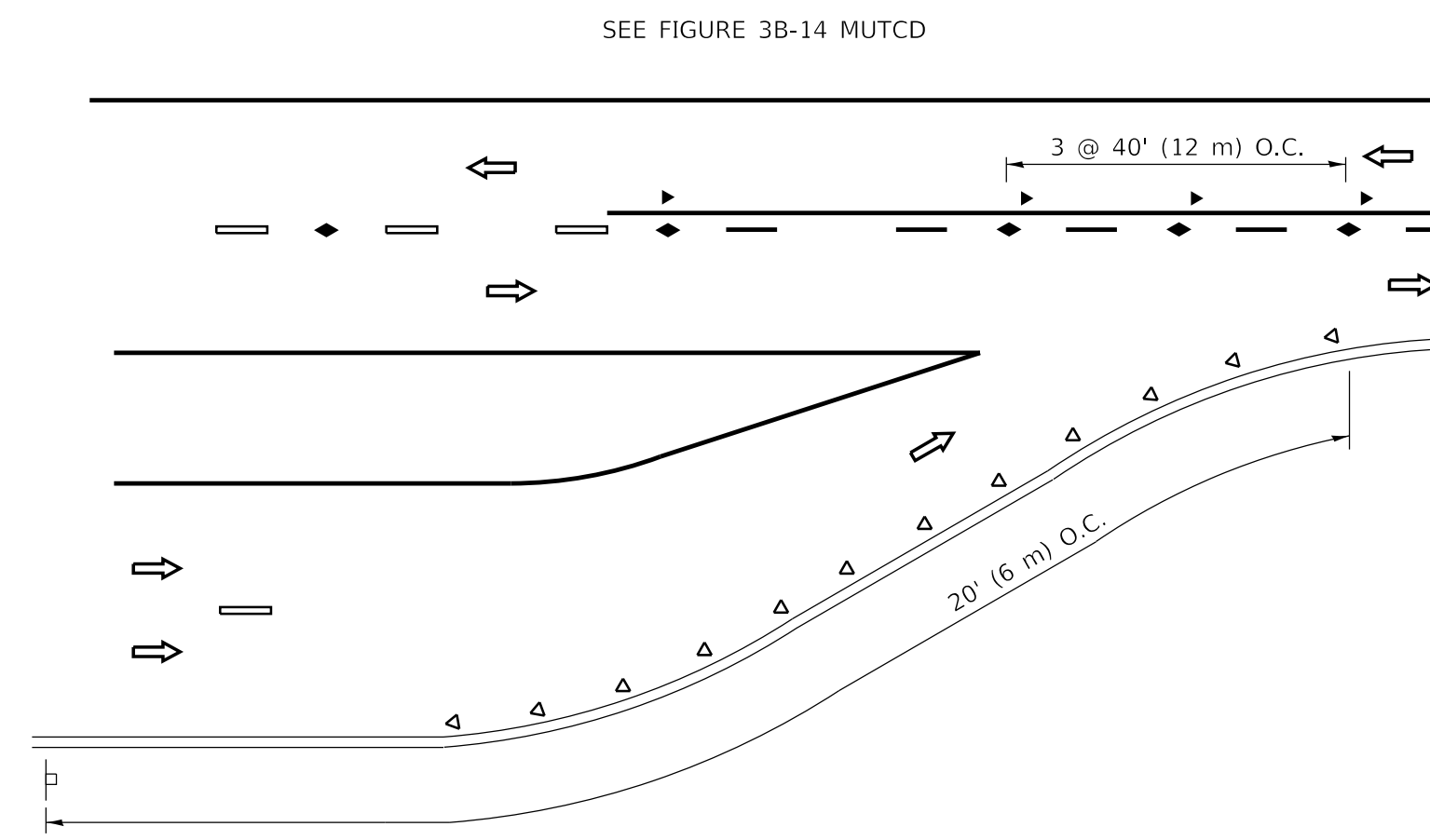

LANE REDUCTION TRANSITION

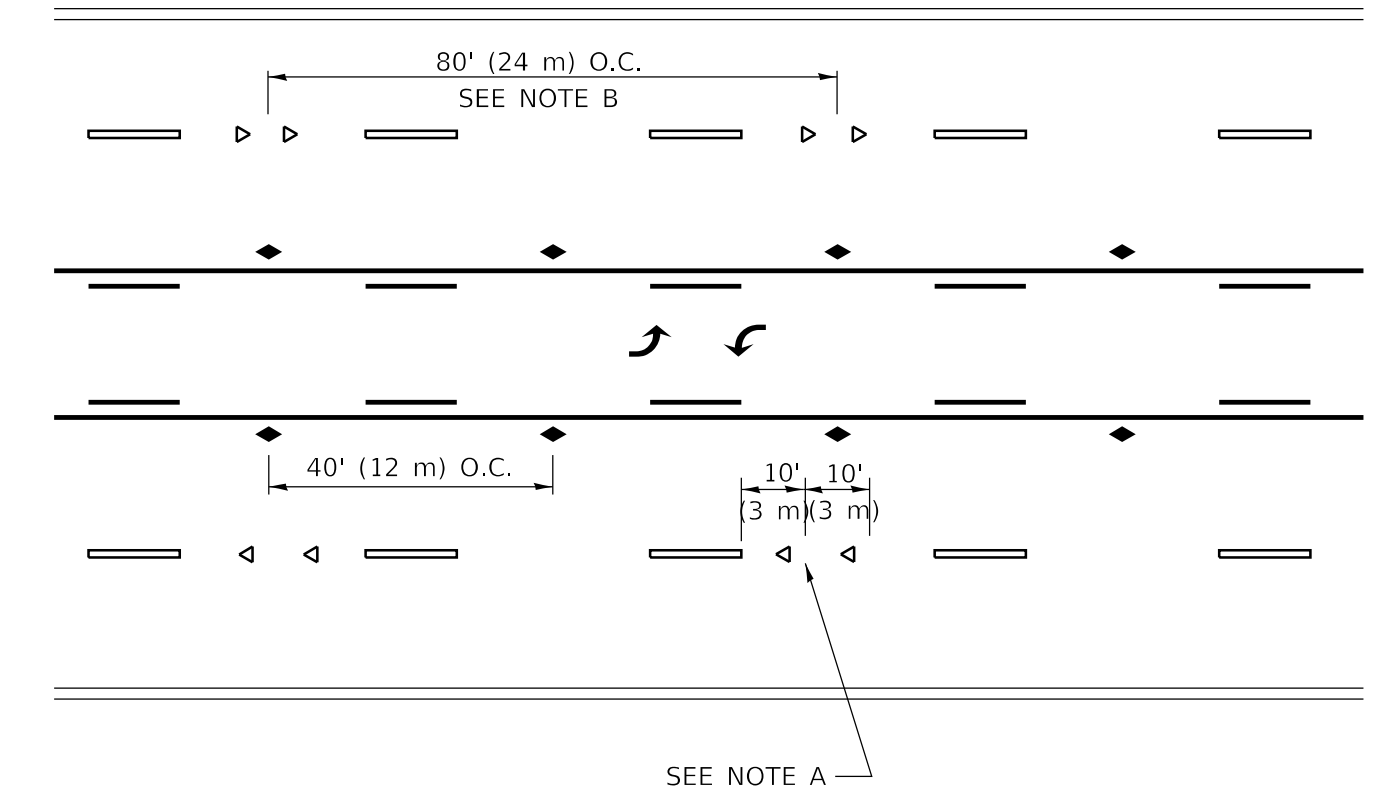

TWO-WAY LEFT TURN

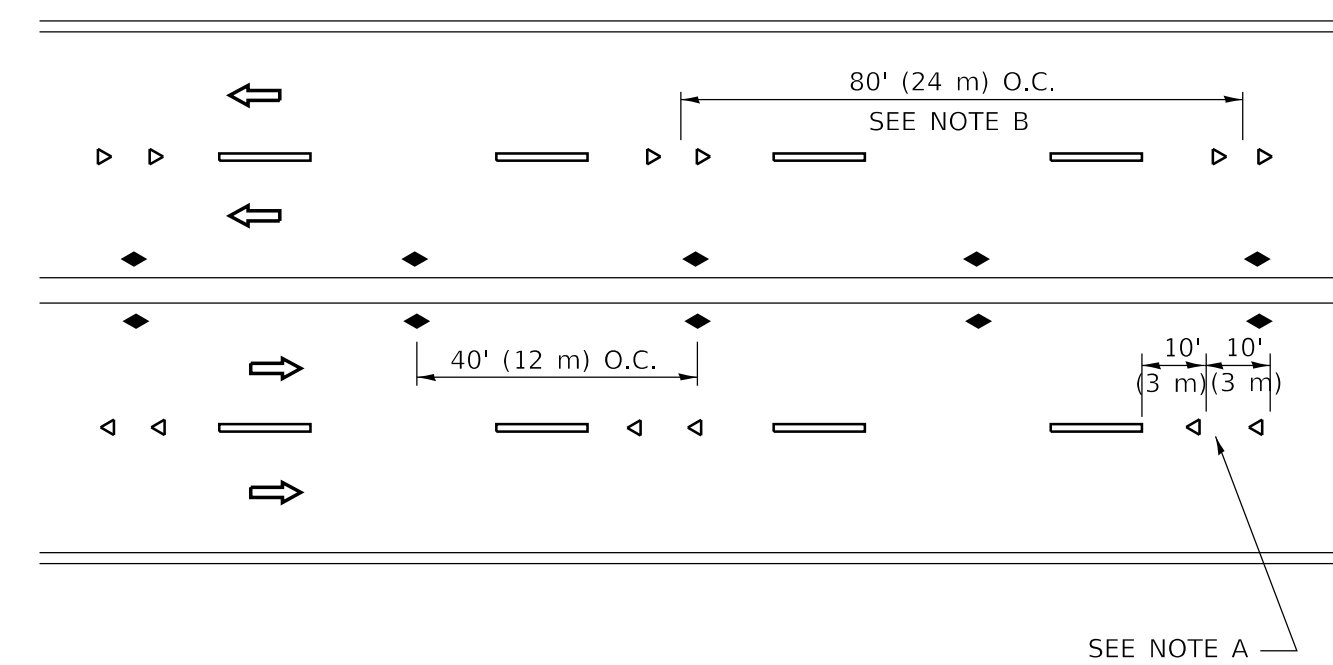

MULTI-LANE/UNDIVIDED

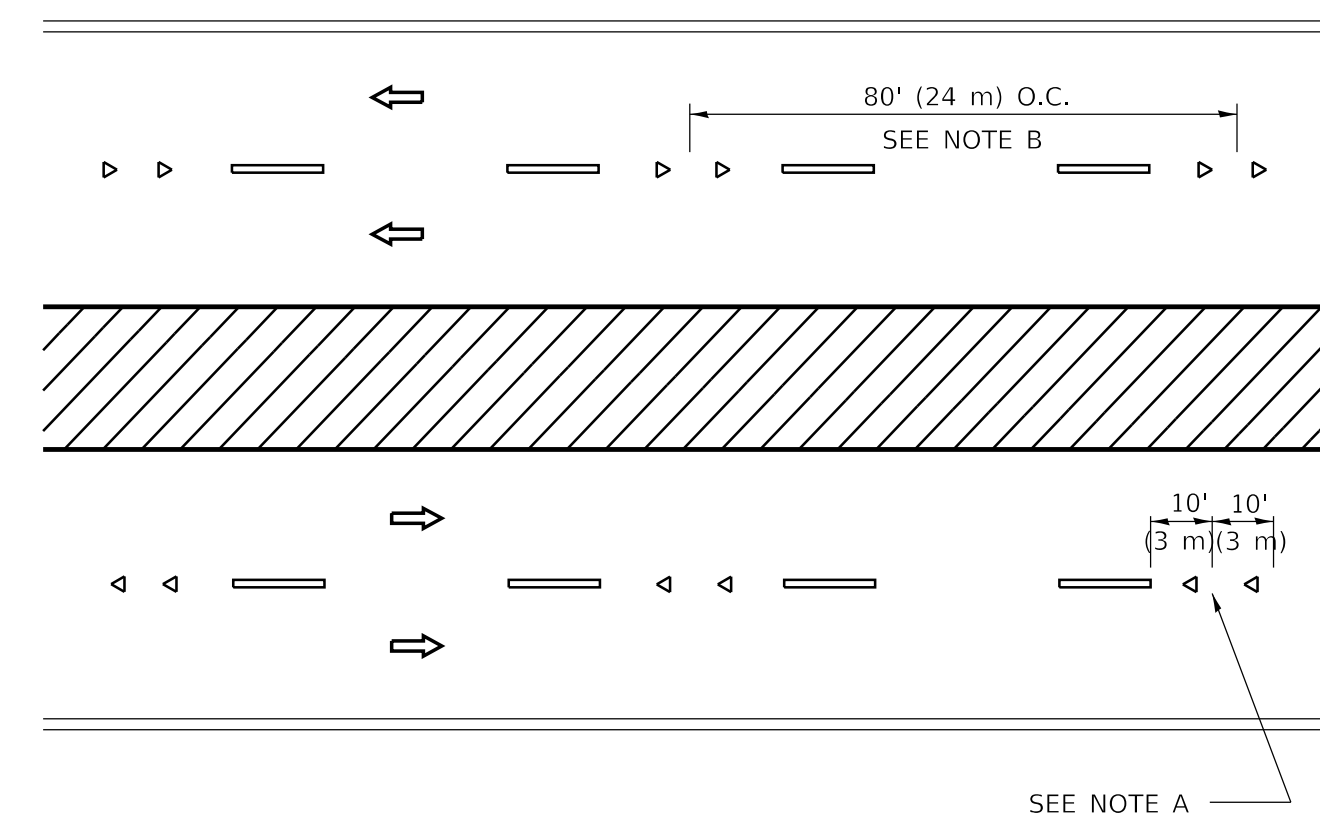

MULTI-LANE/DIVIDED

GENERAL NOTES

1. MARKERS USED WITH DASHED LINES SHALL BE CENTERED IN THE GAP BETWEEN SEGMENTS.
2. MARKERS USED ADJACENT TO SOLID LINES SHALL BE OFFSET 2 TO 3 (50 TO 75) TOWARD TRAFFIC AS SHOWN.
3. MARKERS THROUGH TANGENTS LESS THAN 500' (150 m) IN LENGTH BETWEEN CURVES SHALL BE INSTALLED AT THE LESSER OF THE TWO CURVE SPACINGS.
4. MARKERS ARE TO BE USED ADJACENT TO BOTH SOLID WHITE LINES IN DUAL LEFT TURN LANES

SYMBOLS

- YELLOW STRIPE
- WHITE STRIPE
- ◀ ONE-WAY AMBER MARKER
- ◀ ONE-WAY CRYSTAL MARKER (W/O)
- ◆ TWO-WAY AMBER MARKER

LANE MARKER NOTES

- A. USE DOUBLE LANE LINE MARKERS SPACED AS SHOWN.
- B. REDUCE TO 40' (12 m) O.C. ON CURVES WHERE ADVISORY SPEEDS ARE 10 M.P.H. (20 km/h) LOWER THAN POSTED SPEEDS.

DESIGN NOTES

1. DOUBLE LANE LINE MARKERS SHALL BE USED UNLESS SPECIFIED OTHERWISE.
2. EXCEPT AS SHOWN ON THE LANE REDUCTION TRANSITION AND FREEWAY EXIT RAMP DETAIL, MARKERS ARE NOT TO BE SPECIFIED ON RIGHT EDGE LINES.
3. THE EXACT MARKER LIMITS, SPACING, AND COLOR SHALL BE INCLUDED IN THE PLANS WHEN STANDARD SPECIFICATIONS ARE NOT BEING USED.
4. MARKERS SHOULD NOT BE USED ALONGSIDE CURBS EXCEPT FOR EXTREMELY SHORT SECTIONS OF CURBS WHERE NOT MORE THAN TWO MARKERS WOULD BE INVOLVED.

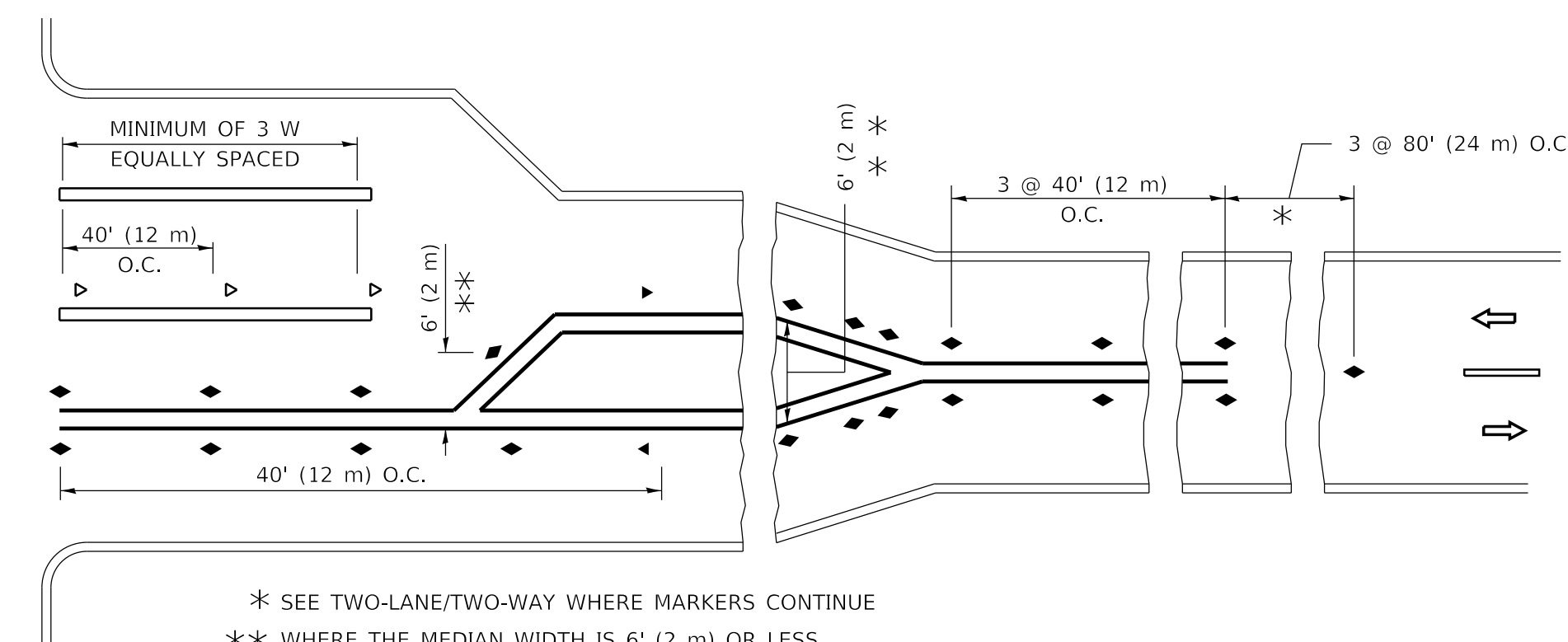
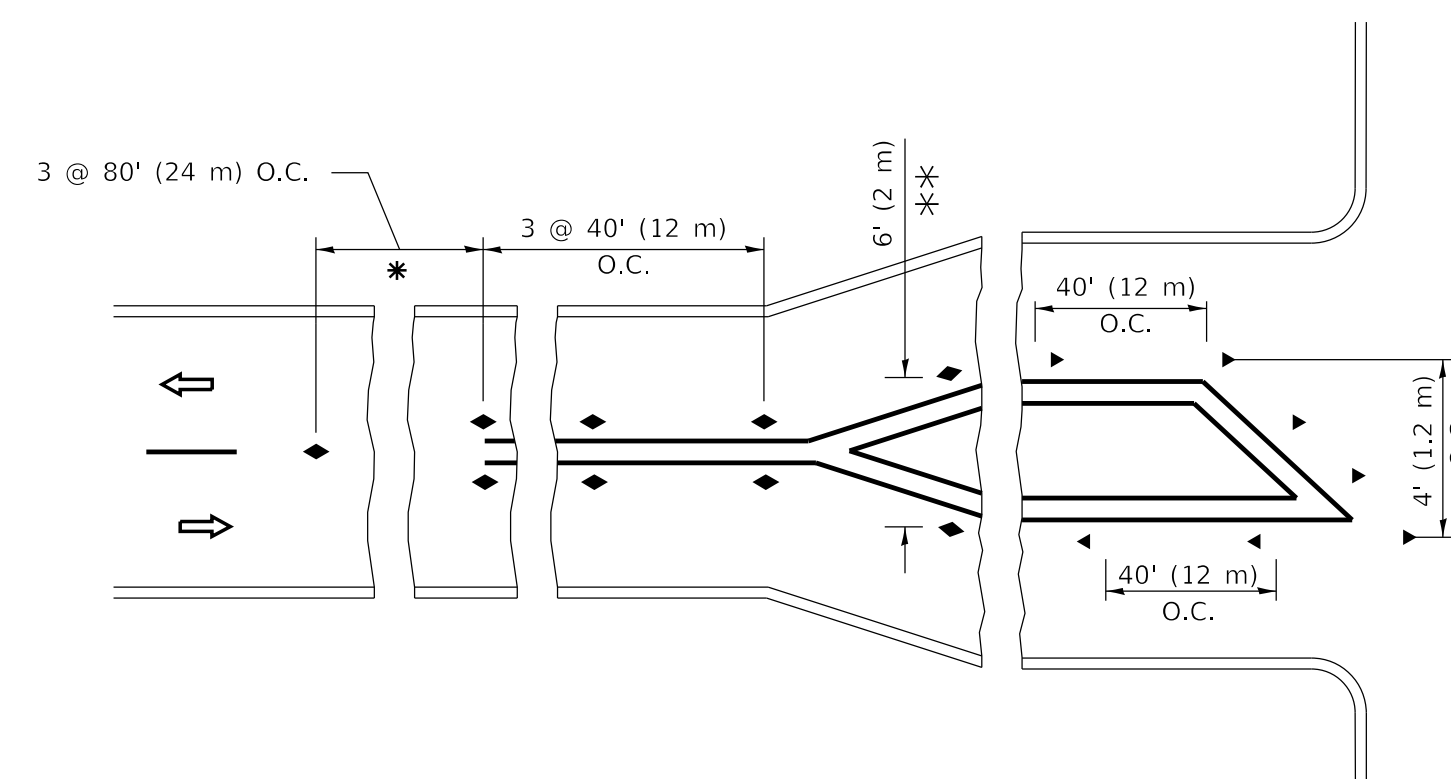

TURN LANES

* SEE TWO-LANE/TWO-WAY WHERE MARKERS CONTINUE
 ** WHERE THE MEDIAN WIDTH IS 6' (2 m) OR LESS USE TWO-WAY MARKERS.

All dimensions are in inches (millimeters) unless otherwise shown.

MODEL: D:\default... PROJECTS\DOT Documents\DOT Offices\District 1\Projects\DOT\22-23\CAD\Drawings\CAD\Sheet\K11.dgn

USER NAME = footemj	DESIGNED -	REVISED - T. RAMMACHER 03-12-99
PLOT SCALE = 50.0000 "/td> <td>DRAWN -</td> <td>REVISED - T. RAMMACHER 01-06-00</td>	DRAWN -	REVISED - T. RAMMACHER 01-06-00
PLOT DATE = 3/4/2019	CHECKED -	REVISED - C. JUCIUS 09-09-09
	DATE -	REVISED - C. JUCIUS 07-01-13

**STATE OF ILLINOIS
DEPARTMENT OF TRANSPORTATION**

**TYPICAL APPLICATIONS
RAISED REFLECTIVE PAVEMENT MARKERS (SNOW-PLOW RESISTANT)**

SCALE: NONE SHEET 1 OF 1 SHEETS STA. TO STA.

F.A. RTE.	SECTION	COUNTY	TOTAL SHEETS	SHEET NO.
TC-11		CONTRACT NO.		
		ILLINOIS FED. AID PROJECT		

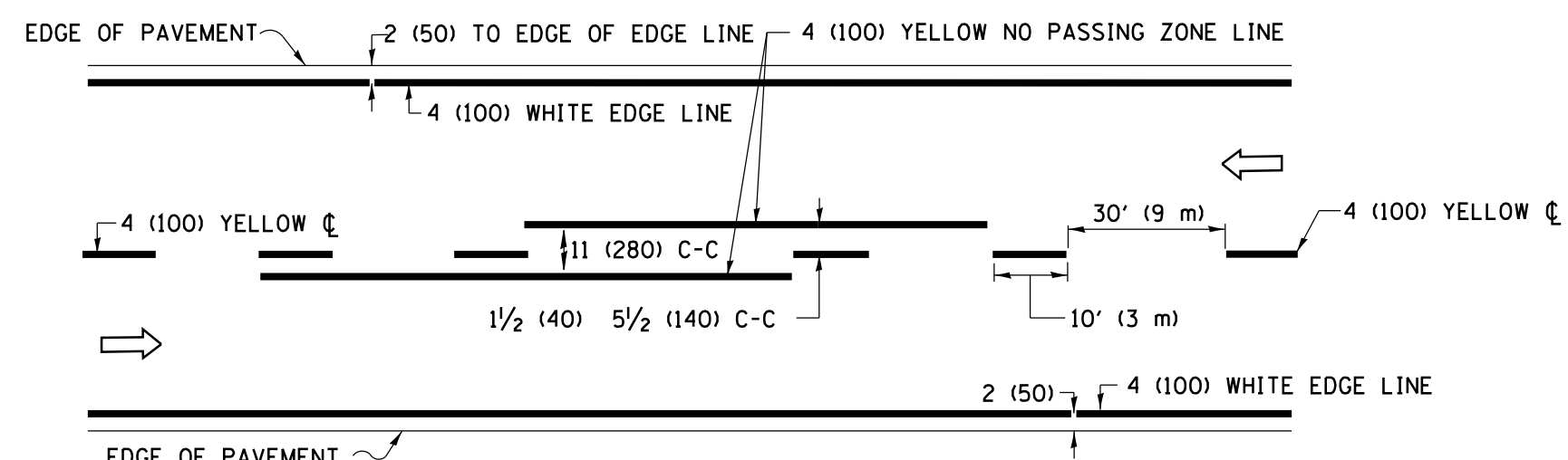

2-LANE ROADWAY

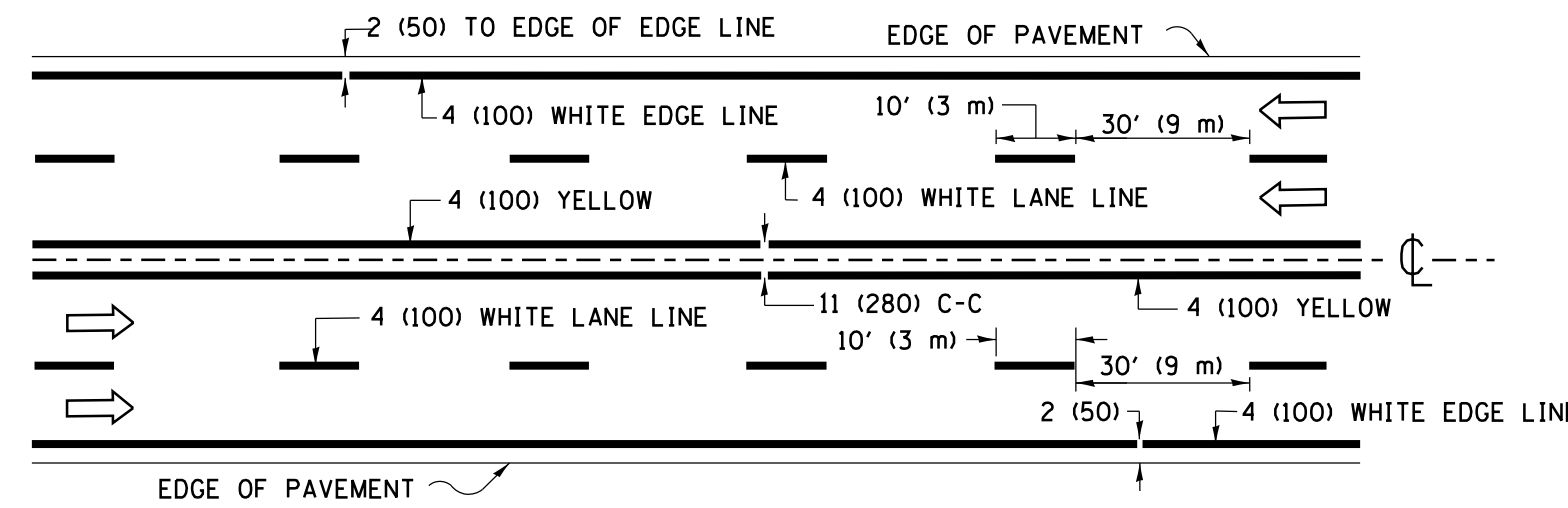

MULTI-LANE UNDIVIDED

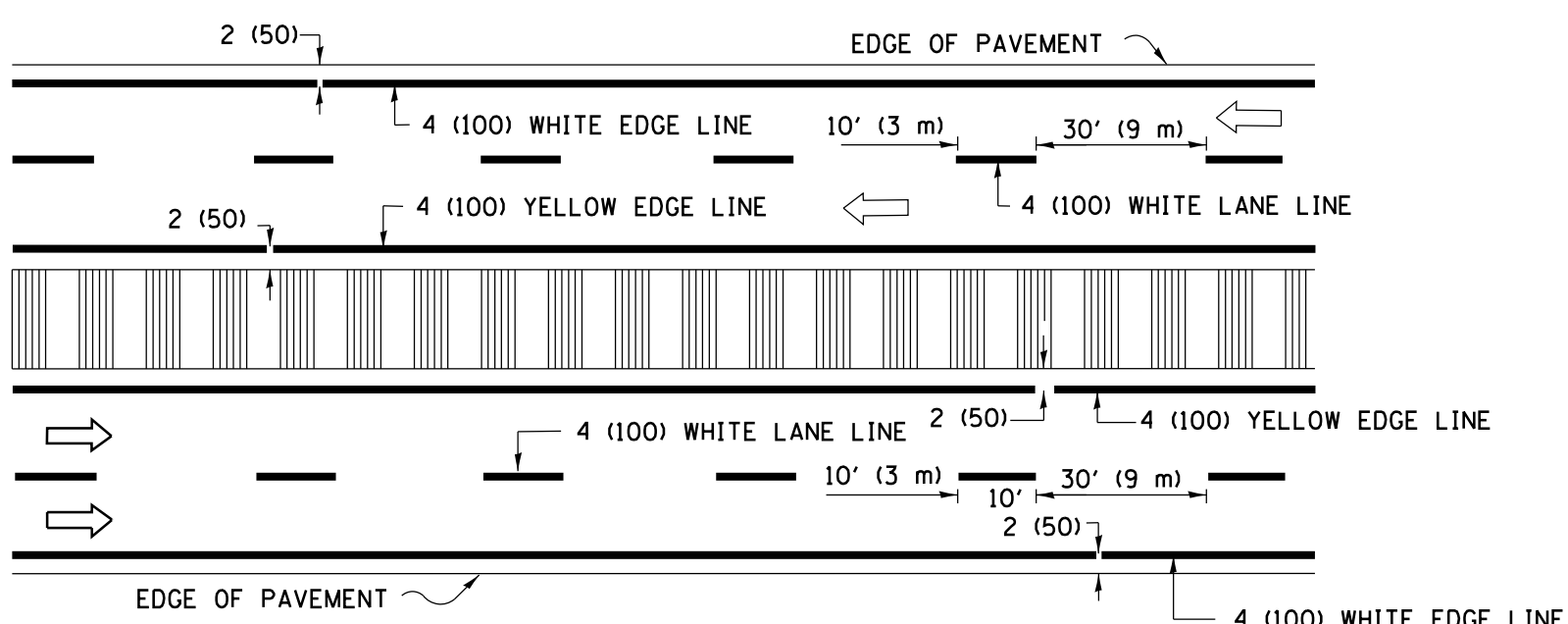

MULTI-LANE DIVIDED WITH MEDIAN

TYPICAL LANE AND EDGE LINE MARKING

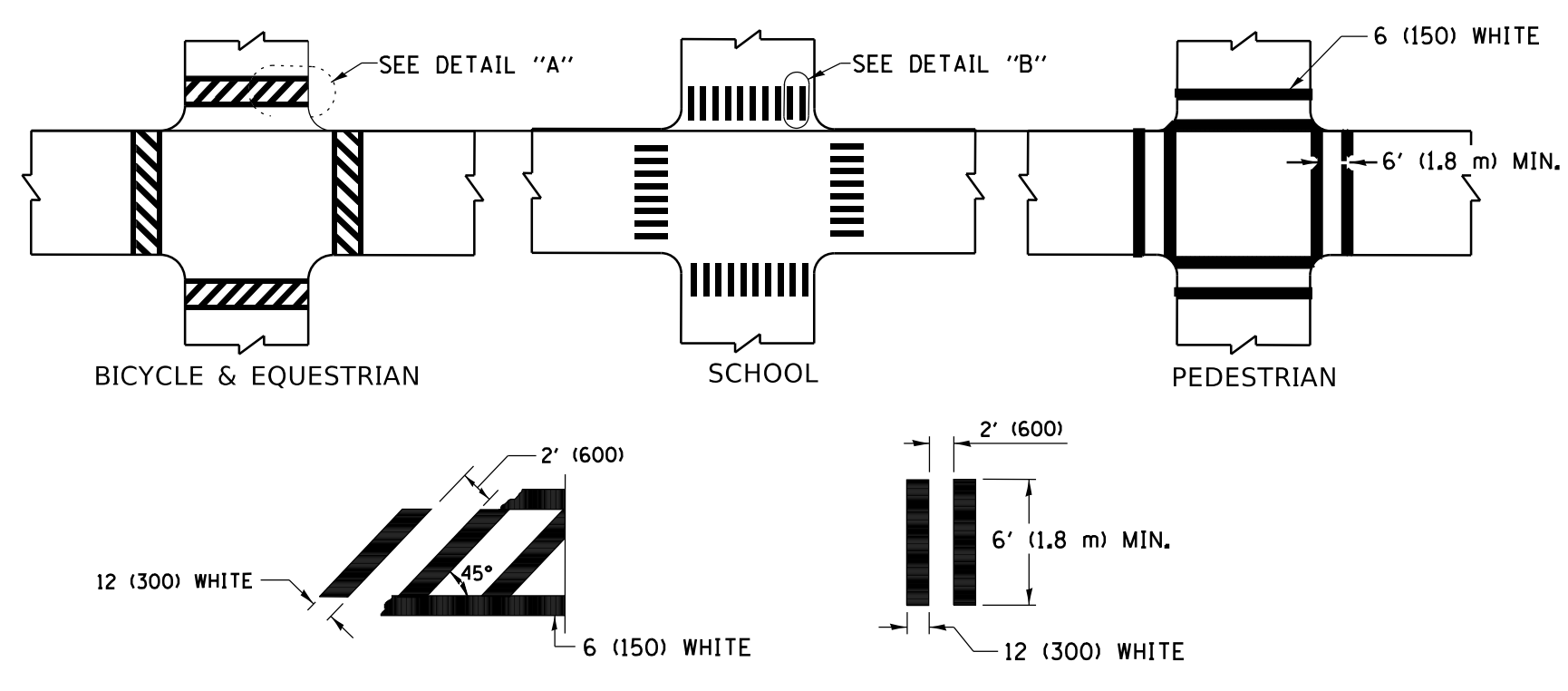

TYPICAL CROSSWALK MARKING

* MARKINGS SHALL BE INSTALLED PARALLEL TO THE CENTERLINE OF THE ROAD WHICH IT CROSSES

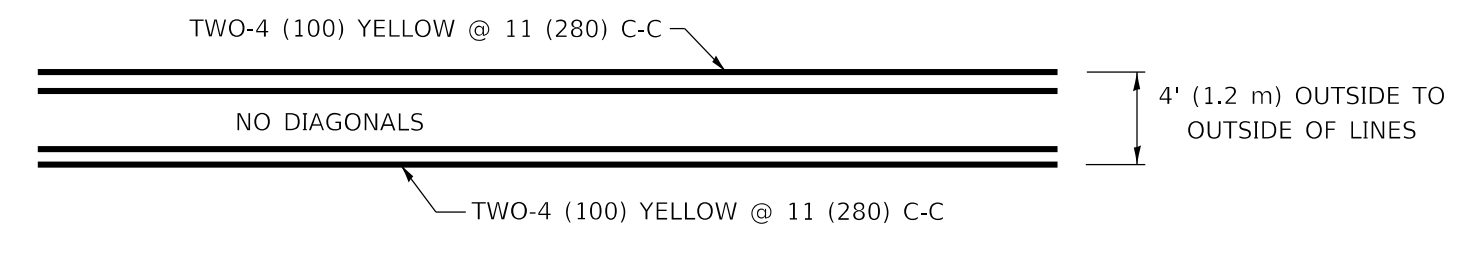

4' (1.2 m) WIDE MEDIANS ONLY

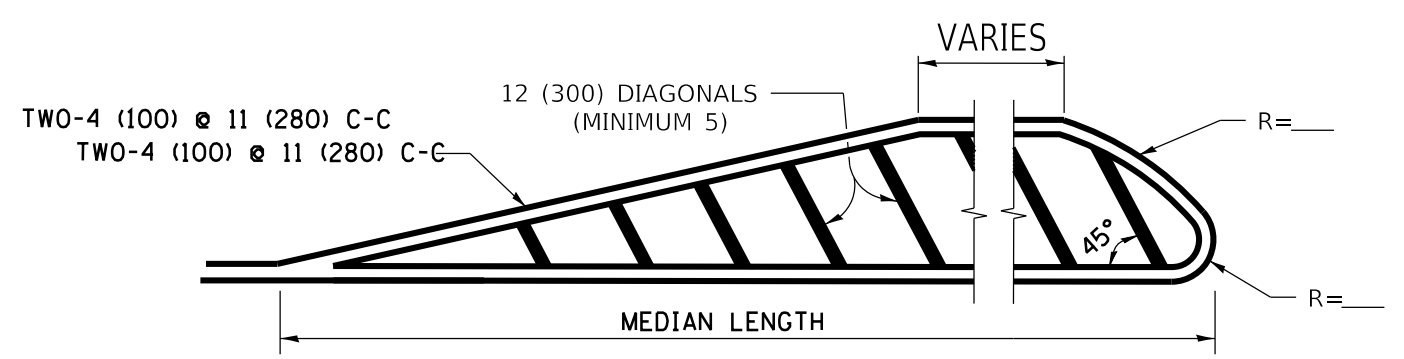

MEDIANS OVER 4' (1.2 m) WIDE

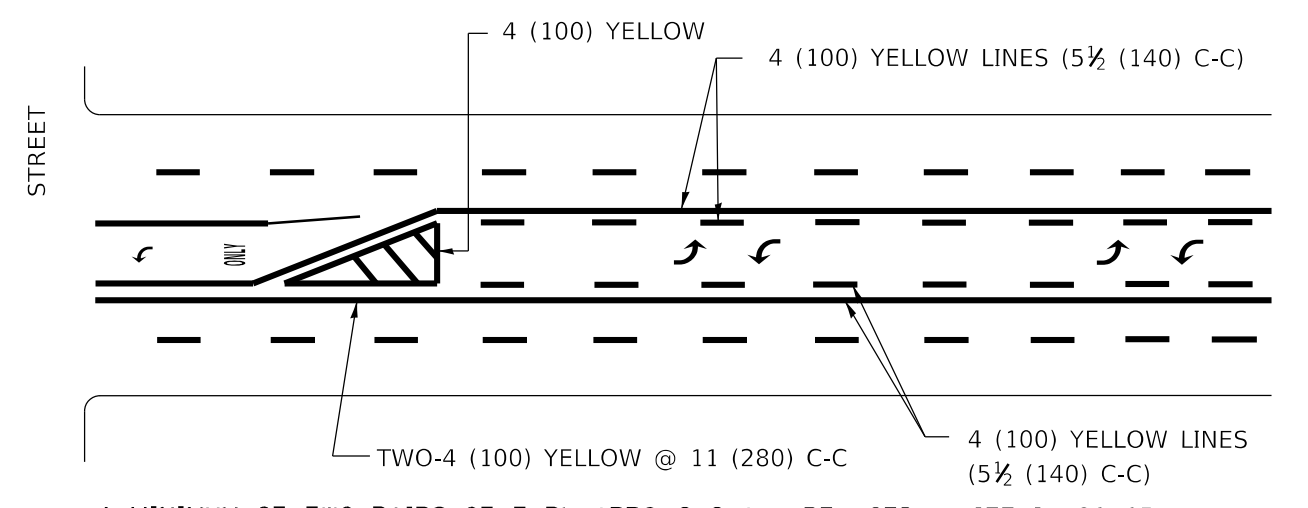

MEDIAN WITH TWO-WAY LEFT TURN LANE TYPICAL PAINTED MEDIAN MARKING

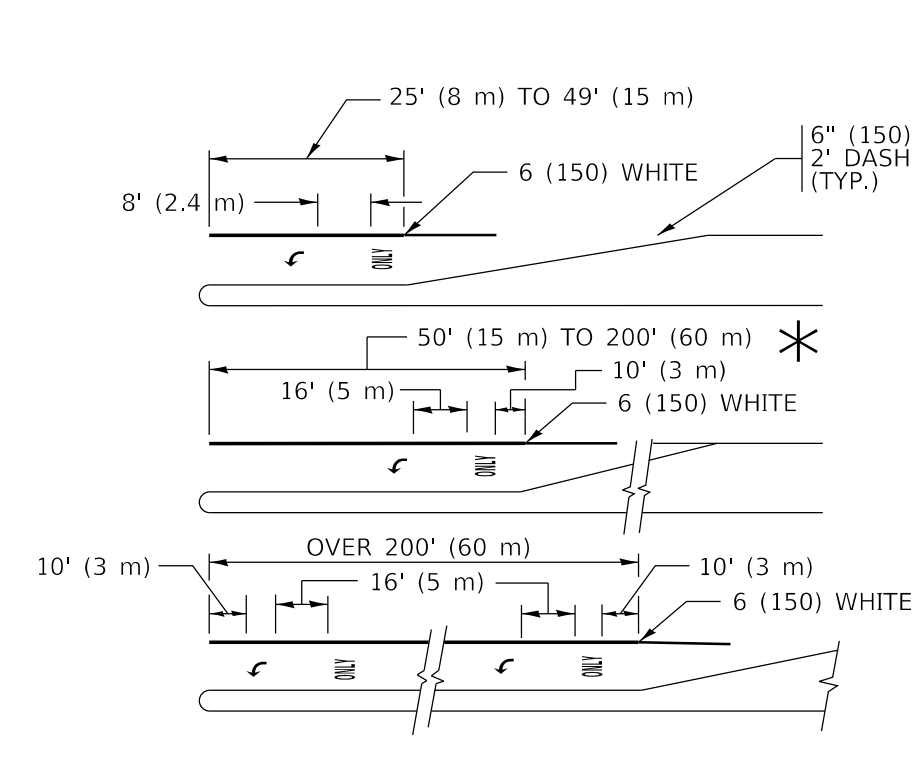

TYPICAL LEFT (OR RIGHT) TURN LANE

TYPICAL TURN LANE MARKING

FULL SIZE LETTERS 8' (2.4 m) AND ARROWS SHALL BE USED.
 AREA = 15.6 SQ. FT. (1.5 m²) ONLY AREA = 20.8 SQ. FT. (1.9 m²)
 * TURN LANES IN EXCESS OF 400' (120 m) IN LENGTH MAY HAVE AN ADDITIONAL SET OF ARROW - "ONLY" INSTALLED MIDWAY BETWEEN THE OTHER TWO SETS OF ARROW - "ONLY".

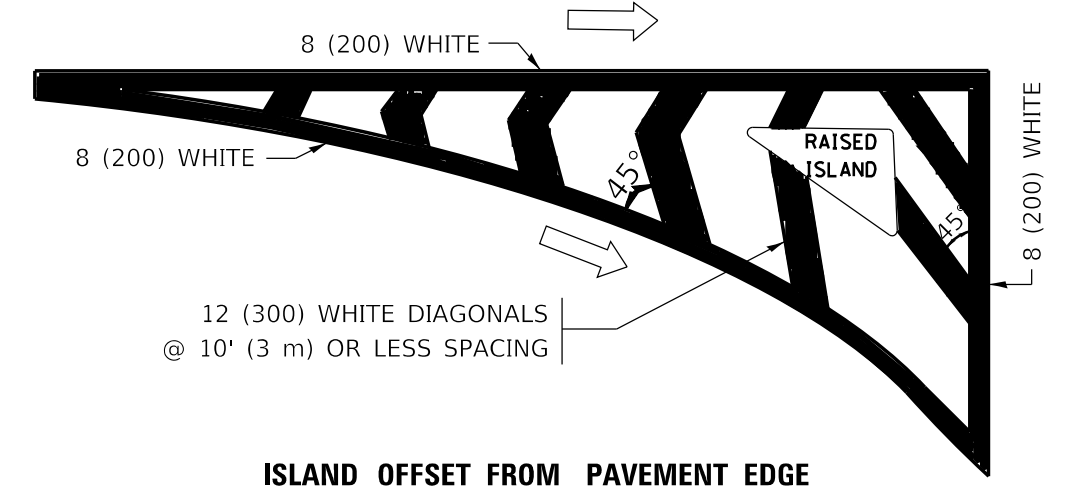

ISLAND OFFSET FROM PAVEMENT EDGE

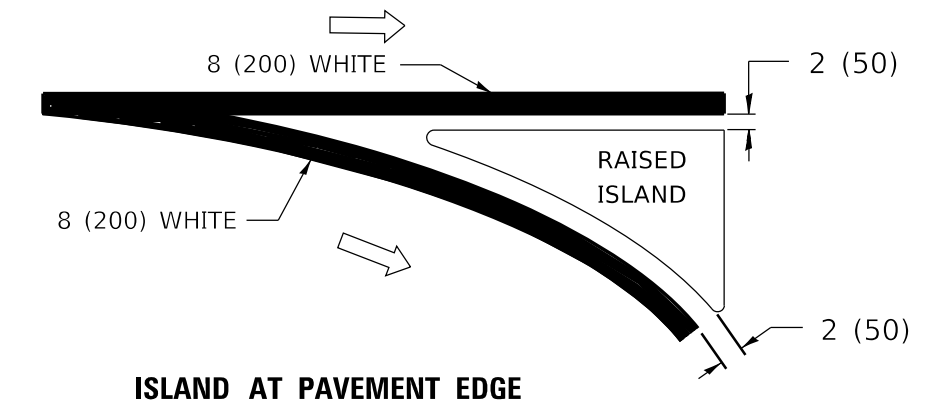

ISLAND AT PAVEMENT EDGE

TYPICAL ISLAND MARKING

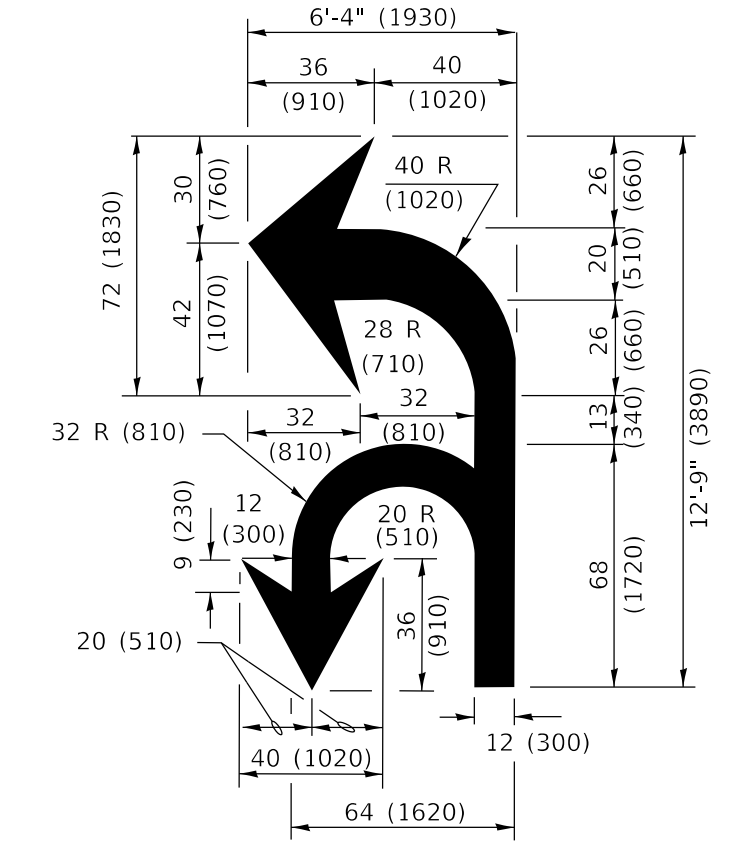

COMBINATION LEFT AND U-TURN

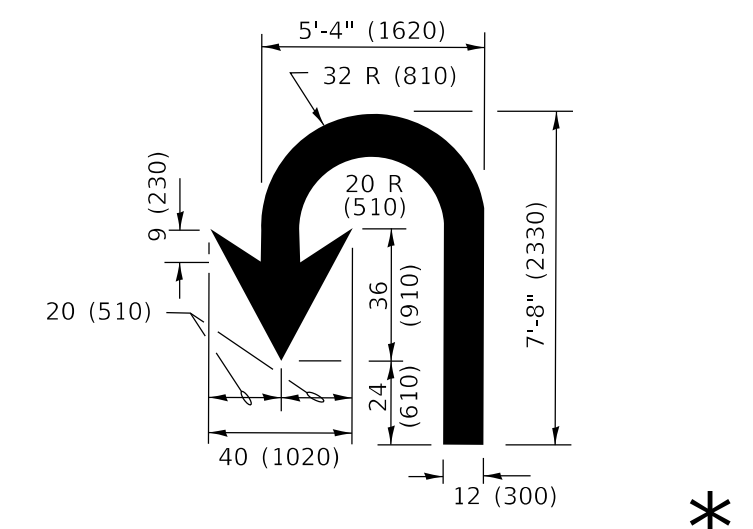

U-TURN

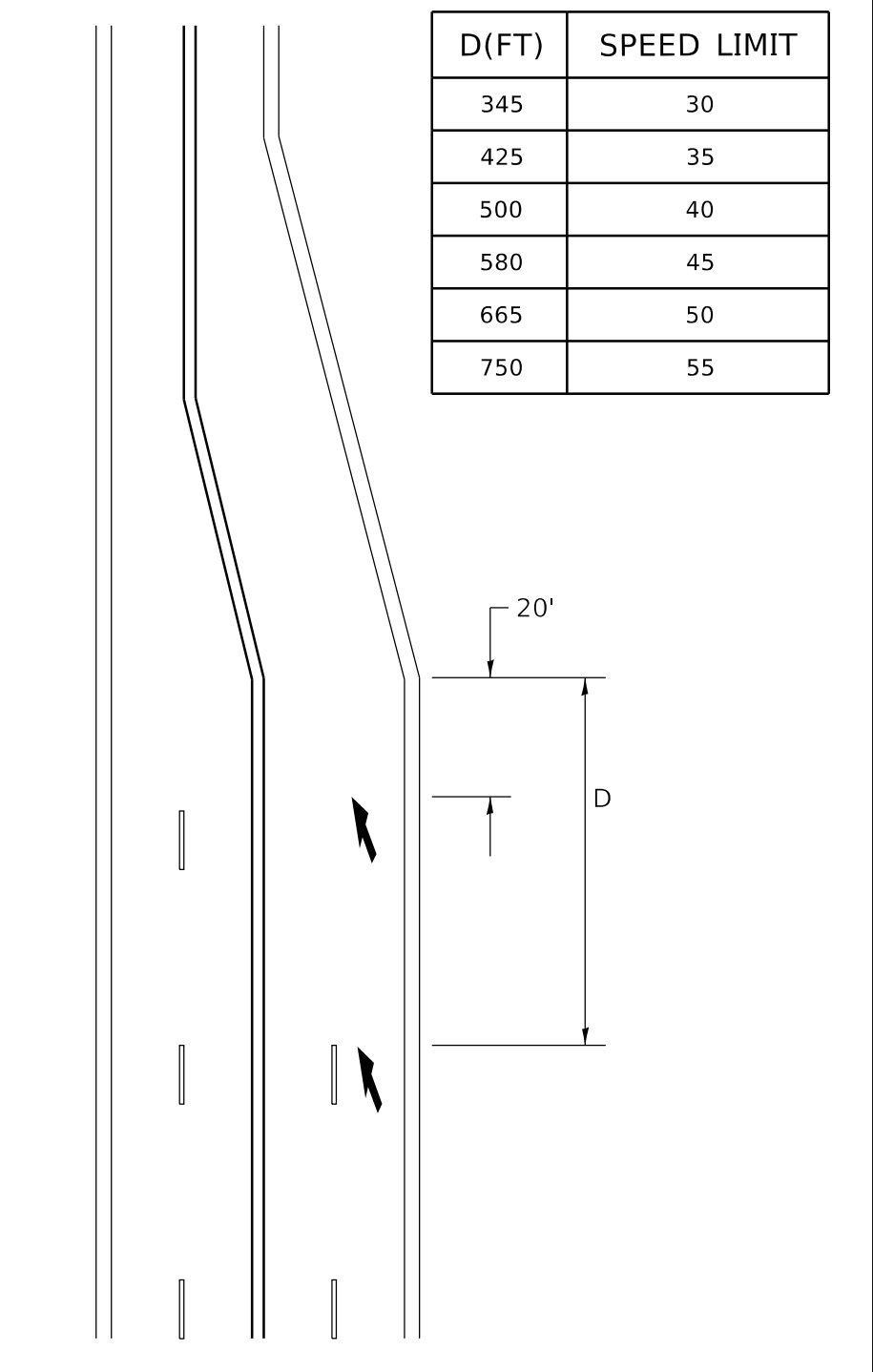

LANE REDUCTION TRANSITION
 * LANE REDUCTION ARROWS REQUIRED AT SPEEDS OF 45 MPH OR GREATER OR WHEN SPECIFIED IN PLANS.

TYPE OF MARKING	WIDTH OF LINE	PATTERN	COLOR	SPACING / REMARKS
CENTERLINE ON 2 LANE PAVEMENT	4 (100)	SKIP-DASH	YELLOW	10' (3 m) LINE WITH 30' (9 m) SPACE
CENTERLINE ON MULTI-LANE UNDIVIDED PAVEMENT	2 @ 4 (100)	SOLID	YELLOW	11 (280) C-C
NO PASSING ZONE LINES: FOR ONE DIRECTION FOR BOTH DIRECTIONS	4 (100) 2 @ 4 (100)	SOLID SOLID	YELLOW YELLOW	5½ (140) C-C FROM SKIP-DASH CENTERLINE 11 (280) C-C OMIT SKIP-DASH CENTERLINE BETWEEN
LANE LINES	4 (100) 5 (125) ON FREEWAYS	SKIP-DASH SKIP-DASH	WHITE WHITE	10' (3 m) LINE WITH 30' (9 m) SPACE
DOTTED LINES (EXTENSIONS OF CENTER, LANE OR TURN LANE MARKINGS)	SAME AS LINE BEING EXTENDED	SKIP-DASH	SAME AS LINE BEING EXTENDED	2' (600) LINE WITH 6' (1.8 m) SPACE
EDGE LINES	4 (100)	SOLID	YELLOW-LEFT WHITE-RIGHT	OUTLINE MEDIANS IN YELLOW
TURN LANE MARKINGS	6 (150) LINE: FULL SIZE LETTERS & SYMBOLS (8' (2.4m))	SOLID	WHITE	SEE TYPICAL TURN LANE MARKING DETAIL
TWO WAY LEFT TURN MARKING	2 @ 4 (100) EACH DIRECTION 8' (2.4m) LEFT ARROW	SKIP-DASH AND SOLID IN PAIRS	YELLOW WHITE	10' (3 m) LINE WITH 30' (9 m) SPACE FOR SKIP-DASH; 5½ (140) C-C BETWEEN SOLID LINE AND SKIP-DASH LINE SEE TYPICAL TWO-WAY LEFT TURN MARKING DETAIL
CROSSWALK LINES (PEDESTRIAN) A. DIAGONALS (BIKE & EQUESTRIAN) B. LONGITUDINAL BARS (SCHOOL)	2 @ 6 (150) 12 (300) @ 45° 12 (300) @ 90°	SOLID SOLID SOLID	WHITE WHITE WHITE	NOT LESS THAN 6' (1.8 m) APART 2' (600) APART 2' (600) APART SEE TYPICAL CROSSWALK MARKING DETAILS.
STOP LINES	24 (600)	SOLID	WHITE	PLACE 4' (1.2 m) IN ADVANCE OF AND PARALLEL TO CROSSWALK, IF PRESENT. OTHERWISE, PLACE AT DESIRED STOPPING POINT. PARALLEL TO CROSSROAD CENTERLINE, WHERE POSSIBLE.
PAINTED MEDIANS	2 @ 4 (100) WITH 12 (300) DIAGONALS @ 45° NO DIAGONALS USED FOR 4' (1.2 m) WIDE MEDIANS	SOLID	YELLOW: TWO WAY TRAFFIC WHITE: ONE WAY TRAFFIC	11 (280) C-C FOR THE DOUBLE LINE SEE TYPICAL PAINTED MEDIAN MARKING.
GORE MARKING AND CHANNELIZING LINES	8 (200) WITH 12 (300) DIAGONALS @ 45°	SOLID	WHITE	DIAGONALS: 15' (4.5 m) C-C (LESS THAN 30MPH (50 km/h)) 20' (6 m) C-C 30MPH (50 km/h) TO 45MPH (70 km/h) 30' (9 m) C-C (OVER 45MPH (70 km/h))
RAILROAD CROSSING	24 (600) TRANSVERSE LINES: "RR" 15 6' (1.8 m) LETTERS; 16 (400) LINE FOR "X"	SOLID	WHITE	SEE STATE STANDARD 780001 AREA OF: "R"=3.6 SQ. FT. (0.33 m ²) EACH "X"=54.0 SQ. FT. (5.0 m ²)
SHOULDER DIAGONALS (REQUIRED FOR SHOULDERS ≥ 8')	12 (300) @ 45°	SOLID	WHITE - RIGHT YELLOW - LEFT	50' (15 m) C-C (LESS THAN 30MPH (50 km/h)) 75' (25 m) C-C (30 MPH (50 km/h) TO 45MPH (70 km/h)) 150' (45 m) C-C (OVER 45MPH (70 km/h))
U TURN ARROW	SEE DETAIL	SOLID	WHITE	16.3 SF
2 ARROW COMBINATION LEFT AND U TURN	SEE DETAIL	SOLID	WHITE	30.4 SF

FOR FURTHER DETAILS ON PAVEMENT MARKING REFER TO STANDARD SPECIFICATIONS FOR ROAD AND BRIDGE CONSTRUCTION AND STATE STANDARD 780001.

All dimensions are in inches (millimeters) unless otherwise shown.

MODEL: Default FILE NAME: p:\u0008\EBID\NTEG\Illinois.gov\p\W\DOT\Documents\DOT_Offices\District_1\Projects\GIS\4222\231\CADD\Drawn\CAD\sheet\110.dwg

USER NAME = footemj	DESIGNED - EVERS	REVISED - C. JUCIUS 09-09-09
PLOT SCALE = 50.0000 "/in.	DRAWN -	REVISED - C. JUCIUS 07-01-13
PLOT DATE = 3/4/2019	CHECKED -	REVISED - C. JUCIUS 12-21-15
	DATE - 03-19-90	REVISED - C. JUCIUS 04-12-16

STATE OF ILLINOIS DEPARTMENT OF TRANSPORTATION

DISTRICT ONE TYPICAL PAVEMENT MARKINGS			
SCALE: NONE	SHEET 1 OF 2 SHEETS	STA. TO STA.	

F.A. RTE.	SECTION	COUNTY	TOTAL SHEETS	SHEET NO.
	TC-13			
ILLINOIS		CONTRACT NO.		
FED. AID PROJECT				

TURN BAY ENTRANCE AT START OF LANE CLOSURE TAPER

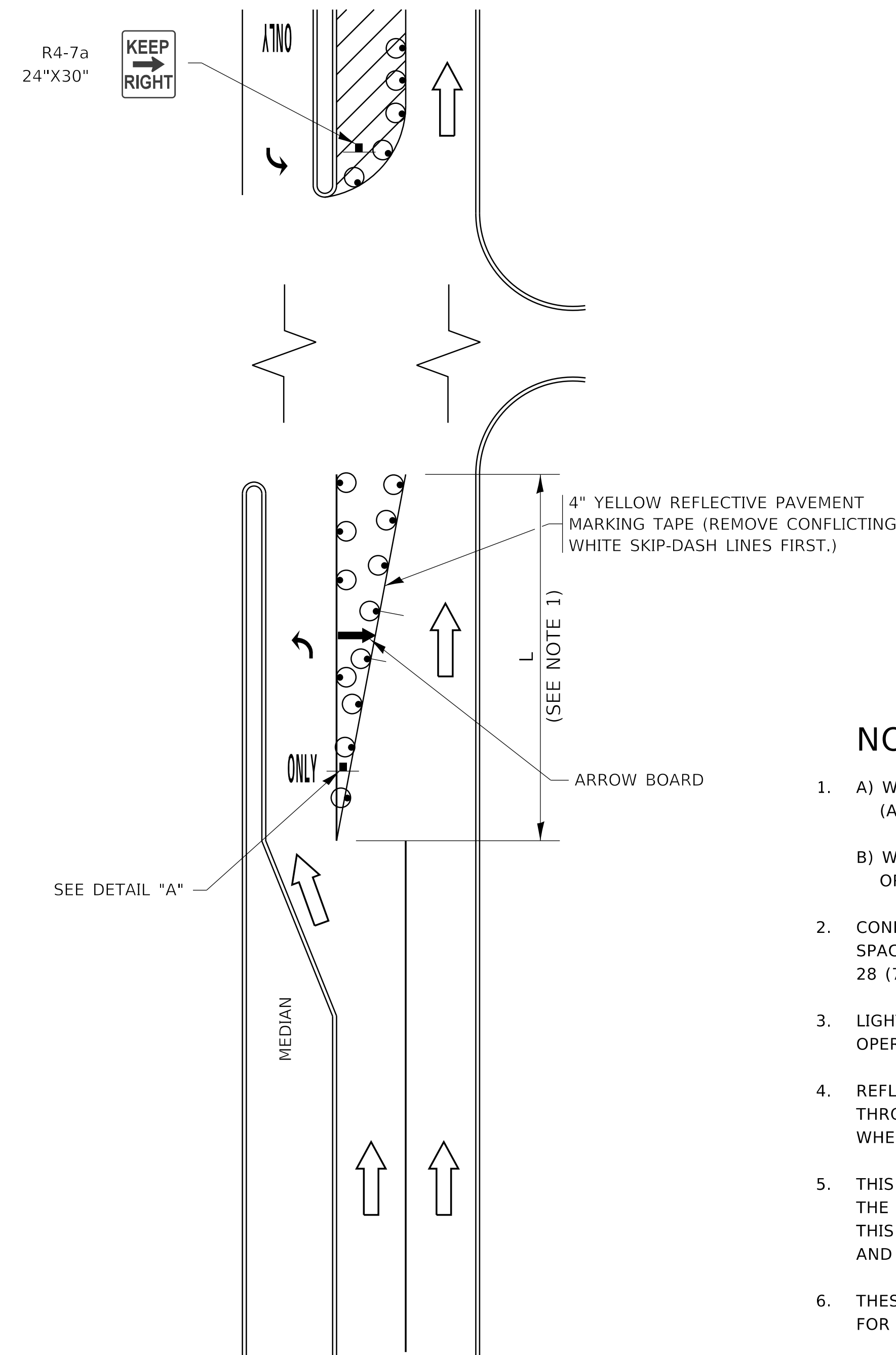

FIGURE 1

TURN BAY ENTRANCE WITHIN A LANE CLOSURE

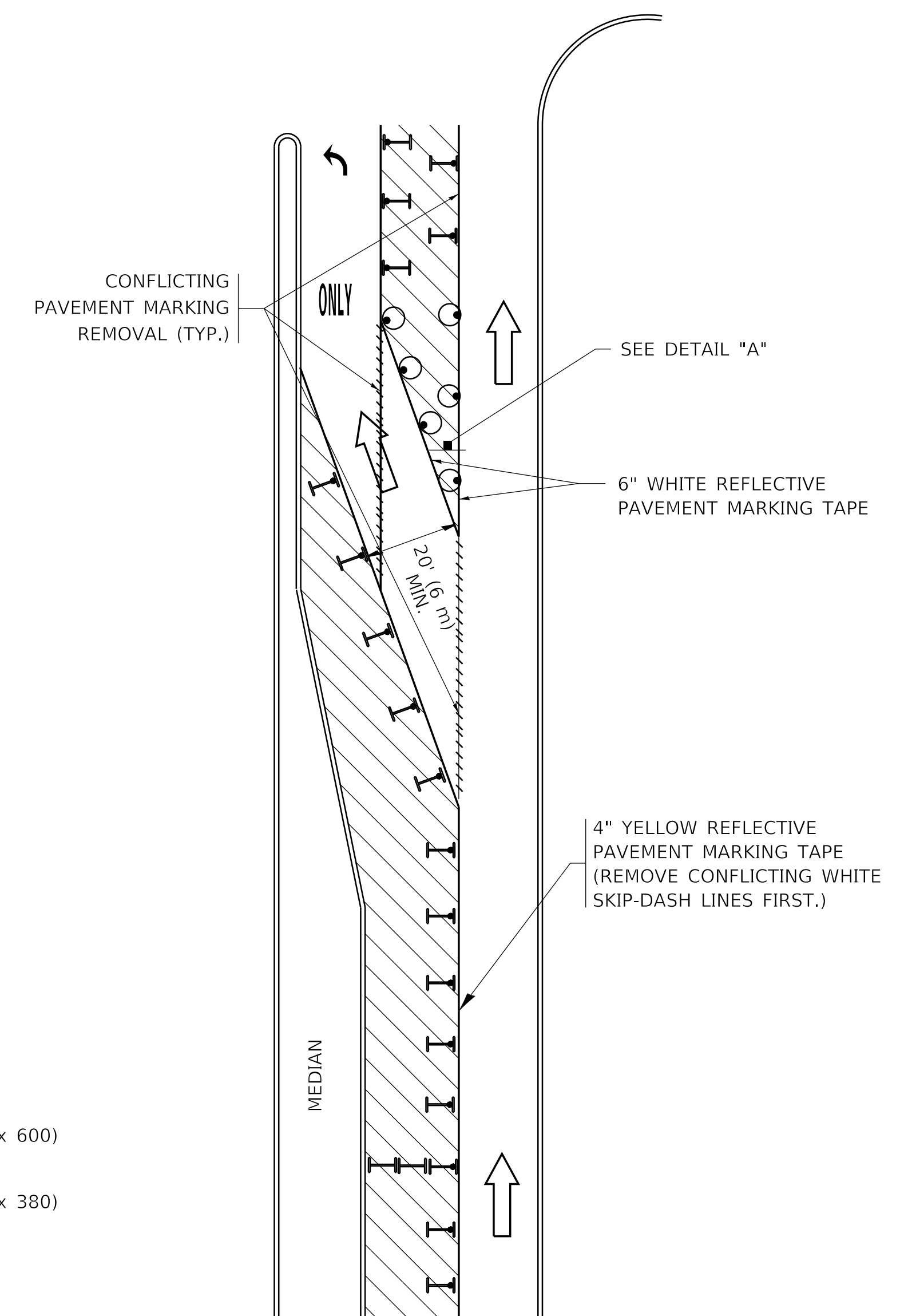

FIGURE 2

LEGEND

- WORK AREA
- LANE OPEN TO TRAFFIC
- ARROW BOARD
- TYPE I OR II BARRICADE OR DRUM WITH STEADY BURN LIGHT
- DRUM WITH STEADY BURN LIGHT
- SIGN ASSEMBLY
- TYPE I OR II CHECK BARRICADE WITH FLASHING LIGHT

NOTES:

1. A) WHEN "L" IS \leq THE STORAGE LENGTH OF THE TURN LANE (AS SHOWN IN FIG. 1), USE FIGURE 1.
 B) WHEN "L" IS $>$ THE STORAGE LENGTH OF THE TURN LANE OR THE TURN LANE IS WITHIN THE LANE CLOSURE, USE FIGURE 2.
2. CONES MAY BE SUBSTITUTED FOR BARRICADES OR DRUMS AT HALF THE SPACING DURING DAY OPERATIONS. CONES SHALL BE A MINIMUM OF 28 (710) IN HEIGHT.
3. LIGHTS WILL NOT BE REQUIRED ON BARRICADES OR DRUMS FOR DAY OPERATIONS. ALL LIGHTS SHALL BE MONODIRECTIONAL.
4. REFLECTIVE TEMPORARY PAVEMENT MARKINGS SHALL BE PLACED THROUGHOUT THE BARRICADED AREAS OF EACH TURN BAY AS SHOWN WHERE THE CLOSURE TIME IS GREATER THAN FOURTEEN (14) DAYS.
5. THIS APPLICATION ALSO APPLIES WHEN WORK IS BEING PERFORMED IN THE RIGHT LANE(S) AND THE RIGHT TURN BAY IS TO REMAIN OPEN. UNDER THIS CONDITION, "RIGHT TURN LANE" R3-1100R 24 x 24 (600 x 600) AND M6-2R 21 x 15 (530 x 380) SHALL BE USED.
6. THESE CONTROLS SHALL SUPPLEMENT MAINLINE TRAFFIC CONTROL FOR LANE CLOSURES.
7. THE SIGNS SHALL BE MOUNTED ABOVE THE BARRICADES/DRUMS ON SEPARATE SIGN SUPPORTS THAT MEET NCHRP 350 OR MASH REQUIREMENTS.
8. TRAFFIC CONTROL AND PROTECTION AT TURN BAYS (TO REMAIN OPEN TO TRAFFIC) SHALL BE INCLUDED IN THE COST OF SPECIFIED TRAFFIC CONTROL STANDARDS OR ITEMS.

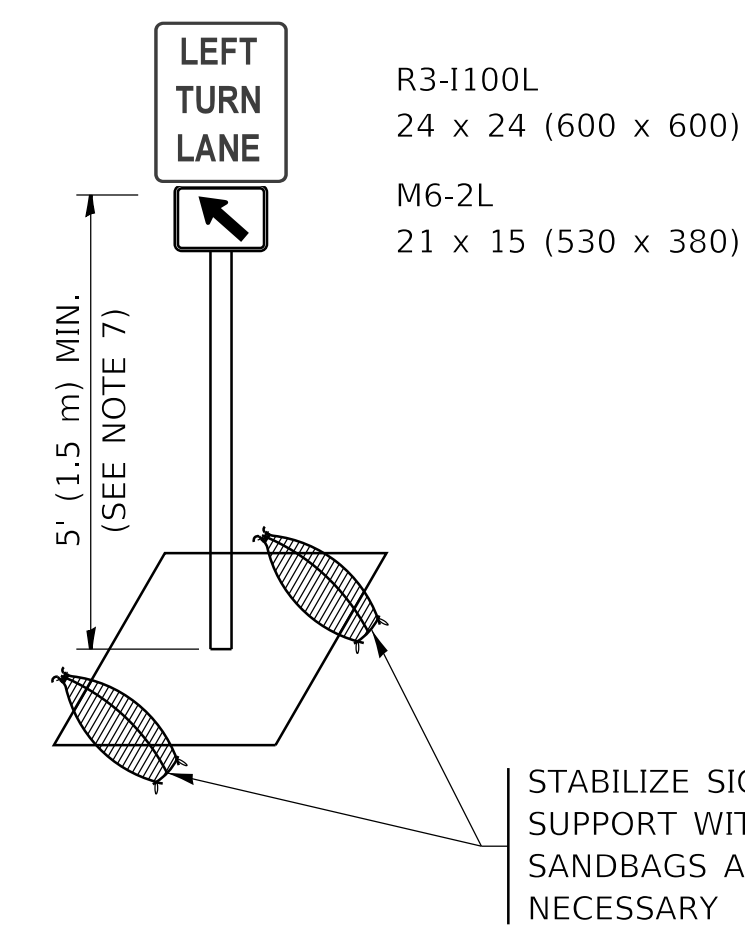

DETAIL A

All dimensions are in inches (millimeters) unless otherwise shown.

MODEL: D:\default...
 FILE NAME: p:\u08\EBID\NTEG...
 PROJECTS:\DOT\Documents\DOT_Offices\District_1\Projects\DH\5422\31\CAD\Drawn\CAD\Sheet\14.dgn

USER NAME = footemj	DESIGNED - T. RAMMACHER 09-08-94	REVISED - R. BORO 09-14-09
	DRAWN - A. HOUSEH 11-07-95	REVISED - A. SCHUETZE 07-01-13
PLOT SCALE = 50.0000 "/td> <td>CHECKED - A. HOUSEH 10-12-96</td> <td>REVISED - A. SCHUETZE 09-15-16</td>	CHECKED - A. HOUSEH 10-12-96	REVISED - A. SCHUETZE 09-15-16
PLOT DATE = 3/4/2019	DATE - T. RAMMACHER 01-06-00	REVISED -

**STATE OF ILLINOIS
DEPARTMENT OF TRANSPORTATION**

**TRAFFIC CONTROL AND PROTECTION AT TURN BAYS
(TO REMAIN OPEN TO TRAFFIC)**

SCALE: NONE SHEET 1 OF 1 SHEETS STA. TO STA.

F.A. RTE.	SECTION	COUNTY	TOTAL SHEETS	SHEET NO.
	TC-14			
ILLINOIS		FED. AID PROJECT		

RECESSED PAVEMENT MARKER

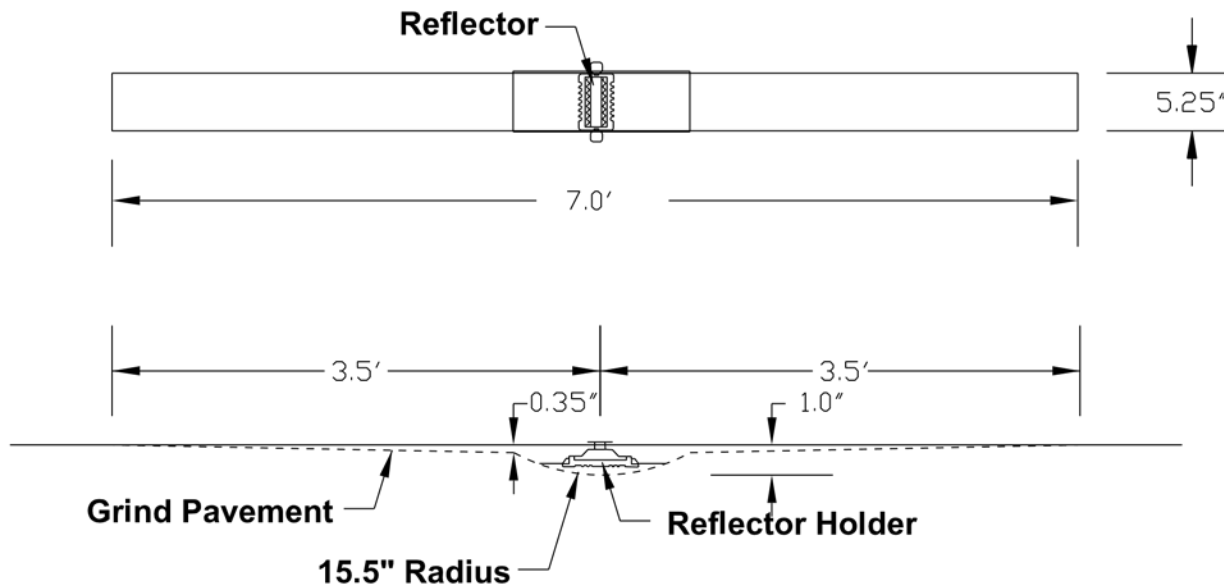

Notes

1. The reflector holder shall be made of a polycarbonate and shall be a MarkerOne Series R100 or Engineer approved equivalent.
2. The adhesive used shall meet the requirements of AASHTO M237 specification for adhesives to be used in cementing asphalt surfaces.
3. For 1-way markers heading uphill, uphill grind taper may be omitted.
4. Markers shall be placed at 80' intervals on lane lines and painted medians and 40' intervals on curves and approaching intersections.

Breakaway tab to fix the reflector depth to 0.10" below the pavement

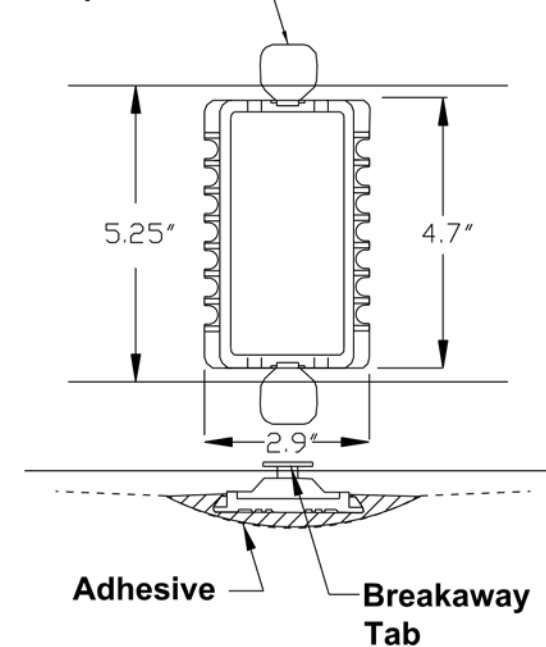

Reflector Holder Detail

PAVEMENT MARKINGS AND PAVEMENT MARKERS

MATERIALS FOR PAVEMENT MARKINGS:

<u>LOCATION</u>	<u>MATERIAL</u>
ALL MARKINGS ON BITUMINOUS PAVEMENT	THERMOPLASTIC PAVEMENT MARKINGS
ALL MARKINGS ON CONCRETE SURFACES	URETHANE PAVEMENT MARKINGS

INSTALLATION OF PAVEMENT MARKINGS:

<u>LOCATION</u>	<u>TYPE OF MARKING</u>
PAINTED MEDIANS	4" DOUBLE YELLOW; 11" c-c AND 12" YELLOW @ 45°; 30' c-c 4" YELLOW
BARRIER MEDIANS	6" WHITE, 2' LONG, 6' SPACE (DOTTED WHITE)
TURN BAY TAPERS ALONG THRU LANES	ARROW AND "ONLY"
START OF TURN BAYS	ADDITIONAL ARROW 10' FROM END
END OF TURN BAYS 150'-200' LONG	ADDITIONAL "ONLY"
TURN BAYS > 200' LONG	

ALL OTHER MARKINGS PER MANUAL OF UNIFORM TRAFFIC CONTROL DEVICES OF ILLINOIS.

INSTALLATION OF RECESSED REFLECTIVE PAVEMENT MARKERS:

<u>LOCATION</u>	<u>SPACING</u>
DOUBLE YELLOW CENTERLINE, & SKIP-DASH WHITE LANE LINES	40'
SOLID LANE LINES (TURN BAYS)	40'
END OF PAINTED MEDIANS	3 @ 3' LATERAL
<u>LOCATION</u>	<u>TYPE</u>
DOUBLE YELLOW CENTERLINE	2-WAY YELLOW
PAINTED MEDIANS \leq 4' WIDE	2-WAY YELLOW
PAINTED MEDIANS >4' WIDE	1-WAY YELLOW
YELLOW LINE ALONG BARRIER MEDIANS	NONE **

** EXCEPT IN SPECIAL CIRCUMSTANCES

SKIP-DASH WHITE LANE LINES, SOLID LANE LINES (TURN BAYS)
2-WAY, UNDIVIDED ROADWAY
1-WAY ROADWAY, OR DIVIDED WITH BARRIER MEDIAN

1-WAY WHITE
2-WAY WHITE / RED



Village of Downers Grove

Contractor Evaluation

Contractor: Superior Road Striping, Inc.

Project: TR-023 Pavement Striping Maintenance

Primary Contact: Sandy DeHoyos Phone: 708-865-0718

Time Period: June 2022

On Schedule (allowing for uncontrollable circumstances) Yes No

Provide details if early or late completion:

Change Orders (attach information if needed): None

Difficulties / Positives: Superior Road Striping is responsive and provide excellent service. The work crews are experienced and knowledgeable.

Interaction with public:

Excellent Good Average Poor

(Attach information on any complaints or compliments)

General Level of Satisfaction with work:

Well Satisfied Satisfied Not Satisfied

Reviewers: Michael Tuman, P.E.

Date: 12/30/22