

**VILLAGE OF DOWNERS GROVE**  
**Report for the Village**  
**3/7/2023**

<b>SUBJECT:</b>	<b>SUBMITTED BY:</b>
Award of Contract - Right-of-Way Accessibility Improvements	Andy Sikich Public Works Director

**SYNOPSIS**

A motion is requested to award a contract for the 2023 Right-of-Way (ROW) Accessibility Improvements to Alliance Contractors, Inc. of Woodstock, Illinois in the amount of \$497,297.50.

**STRATEGIC PLAN ALIGNMENT**

The goals for 2021 to 2023 include Top Quality Infrastructure.

**FISCAL IMPACT**

The FY23 budget includes \$400,000.00 in the Capital Improvements Fund for ROW Accessibility Improvements (S-008). The remainder will be taken from fund balance in the Capital Improvements Fund.

**RECOMMENDATION**

Approval on the March 7, 2023 consent agenda.

**BACKGROUND**

This project includes modification of existing sidewalks and ramps that require engineering design and plans to bring them into compliance with American with Disabilities (ADA) and Public Rights of Ways Accessibility Guidelines (PROWAG) standards. Staff has prioritized locations that are in need of upgrades and selected them on the basis of severity, need and constructability. This year's project includes 15 separate locations around the Village that have been previously identified.

A Call for Bids was issued and published in accordance with the Village's Purchasing Policy. One bid was received and publicly opened on Wednesday, February 22, 2023.

Staff recommends award of this contract to Alliance Contractors, Inc. Alliance has satisfactorily completed multiple projects for the Village, including the 2016 and 2021 ROW Accessibility Improvements as well as the 2022 DBD Crosswalks Upgrades.

**ATTACHMENTS**

Contract Documents  
Contractor Evaluation

## Village of Downers Grove – 2023 ROW ACCESSIBILITY IMPROVEMENTS (S-008-23)

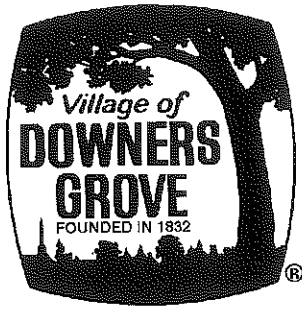

## CALL FOR BIDS – FIXED WORKS PROJECT

- I. Name of Company Bidding: Alliance Contractors, Inc.
- II. Instructions and Specifications:
- |                                  |   |
|----------------------------------|---|
| A. Bid No.:                      | <u>S-008-23</u>   |
| B. DemandStar Bid No:            | <u>CFB-12-0-2023/MWS</u>  |
| C. For:                          | <u>2023 ROW ACCESSIBILITY IMPROVEMENTS</u>                              |
| D. Bid Opening Date/Time:        | <u>Wednesday, February 22, 2023 @ 9:00 AM</u>                           |
| E. Pre-Bid Conference Date/Time: | <u>Wednesday, February 15, 2023 @ 9:30 AM</u><br><u>(Optional)</u>      |
| F. Pre-Bid Conference Location:  | <u>Public Works Building, 5101 Walnut Ave., Downers Grove, IL 60515</u> |
- III. Required of All Bidders:
- |  |            |
|--|------------|
| A. Bid Deposit:  | <u>5%</u>  |
| B. Letter of Capability of Acquiring Performance Bond: | <u>YES</u> |
- IV. Required of Awarded Contractor(s)
- |  |            |
|--|------------|
| A. Performance Bond or Letter of Credit: | <u>YES</u> |
| B. Certificate of Insurance:             | <u>YES</u> |

Legal Advertisement Published: February 8, 2023

This document comprises 76 pages.

RETURN ORIGINAL BID (NO STAPLES) IN SEALED ENVELOPE MARKED WITH THE BID NUMBER AS NOTED ABOVE TO :

MATT STERN  
 VILLAGE OF DOWNERS GROVE  
 5101 WALNUT AVE.  
 DOWNERS GROVE, IL 60515  
 PHONE: 630/434-5463  
 FAX: 630/434-5495  
[www.downers.us](http://www.downers.us)

## Village of Downers Grove – S-008-23 ROW ACCESSIBILITY IMPROVEMENTS

**CALL FOR BIDS – FIXED WORKS PROJECT****Bid No.:** S-008-23

The VILLAGE OF DOWNERS GROVE will receive bids Monday through Friday, 8:00 A.M. to 5:00 P.M. at the Public Works Building, 5101 Walnut Avenue, Downers Grove, IL 60515.

The Village Council reserves the right to accept or reject any and all bids, to waive technicalities and to accept or reject any item of any Bid.

The documents constituting component parts of this Contract are the following:

- I. CALL FOR BIDS
- II. TERMS & CONDITIONS
- III. GENERAL PROVISIONS
- IV. SPECIAL PROVISIONS
- V. BID & CONTRACT FORM

All Bidders MUST submit the entire bid package, with one original Bid Form. Upon formal Award, the successful Bid will automatically convert to a Contract, and the successful Bidder will receive a copy of the executed contract upon formal award of the Bid with the Notice of Award.

**DO NOT DETACH ANY PORTION OF THIS DOCUMENT. INVALIDATION COULD RESULT.**

**PLEASE DO NOT BIND ANY PORTION OF THE BID WITH STAPLES.**

**ALL PAGES OF THE BID MUST BE SUBMITTED SINGLE-SIDED.**

## Village of Downers Grove – S-008-23 ROW ACCESSIBILITY IMPROVEMENTS

**I. CALL FOR BIDS and INSTRUCTIONS TO BIDDERS****1. GENERAL**

- 1.1 Notice is hereby given that Village of Downers Grove will receive sealed bids up to the time and date set forth on the cover page of this Call for Bids.
  - 1.2 Defined Terms:
    - 1.2.1 Village – the Village of Downers Grove acting through its officers or agents.
    - 1.2.2 Contract Documents – this document plus any drawings issued therewith, any addenda and the Bidder’s completed proposal, bonds and all required certifications.
    - 1.2.3 Bid – this document completed by an individual or entity and submitted to the Village.
    - 1.2.4 Bidder – the individual or entity who submits or intends to submit a bid proposal to the Village.
    - 1.2.5 Contractor – the individual or entity whose bid is selected by the Village and who enters into a contract with the Village.
    - 1.2.6 Work – the construction or service defined herein.
    - 1.2.7 Day – unless otherwise stated all references to day “Day” “Days”, “day” or “days” shall refer to calendar days.
    - 1.2.8 Proposal Guaranty – the required bid deposit.
  - 1.3 Bids must be received at the Village by the time and date specified. Bids received after the specified time and date will not be accepted and will be returned unopened to the Bidder.
  - 1.4 Bids shall be sent to the Village of Downers Grove, ATTN: MATT STERN, in a sealed envelope marked "SEALED BID." The envelope shall be marked with the name of the project, date, and time set for receipt of Bids. The bid package may be submitted any time prior to the time set for receipt of Bids.
  - 1.5 All Bids must be submitted on the forms supplied by the Village and signed by a proper official of the company submitting the Bid. Telephone, email and fax Bids will not be accepted.
  - 1.6 Under penalty of perjury, the Bidder certifies by submitting this Bid that he has not acted in collusion with any other Bidder or potential Bidder.
- 2. BID PREPARATION**
- 2.1 It is the responsibility of the Bidder to carefully examine the Contract Documents and to be familiar with all of the requirements, stipulations, provisions, and conditions surrounding the proposed Work.

## Village of Downers Grove – S-008-23 ROW ACCESSIBILITY IMPROVEMENTS

- 2.2 The Bidder shall inspect the site of the proposed Work in detail, investigate and become familiar with all the local conditions affecting the Work and become fully acquainted with the detailed requirements of the Work. Submitting a Bid shall be a conclusive assurance and warranty that the Bidder has made these examinations and that the Bidder understands all requirements for the performance of the Work. If the Bid is accepted, the Bidder will be responsible for all errors in the Bid resulting from his willing or neglectful failure to comply with these instructions. IN NO CASE WILL THE VILLAGE BE RESPONSIBLE FOR ANY COSTS, EXPENSES, LOSSES OR CHANGES IN ANTICIPATED MARGINS OF PROFIT RESULTING FROM THE WILLING OR NEGLECTFUL FAILURE OF THE BIDDER TO MAKE THESE EXAMINATIONS. THE VILLAGE WILL NOT BE RESPONSIBLE FOR ANY COSTS, EXPENSES, LOSSES OR CHANGES IN ANTICIPATED MARGINS OF PROFIT RESULTING FROM THE WILLING OR NEGLECTFUL FAILURE OF THE CONTRACTOR TO PROVIDE THE KNOWLEDGE, EXPERIENCE AND ABILITY TO PERFORM THE WORK REQUIRED BY THIS CONTRACT. No changes in the prices, quantities or contract provisions shall be made to accommodate the inadequacies of the Bidder, which might be discovered subsequent to award of contract. The Bidder shall take no advantage of any error or omission in the Contract Documents nor shall any error or omission in the Contract Documents serve as the basis for an adjustment of the amounts paid to the Bidder.
- 2.3 When the Contract Documents include information pertaining to subsurface explorations, borings, test pits, and other preliminary investigations, such information is included solely for the convenience of the Bidder. *The Village assumes no responsibility whatsoever with respect to the sufficiency of the information, and does not warrant, neither expressly nor by implication, that the conditions indicated represent those existing throughout the Work, or that unanticipated developments may not occur.*
- 2.4 Any information shown in the Contract Documents regarding the locations of underground utility facilities is included solely for the convenience of the Bidder. The Village assumes no responsibility whatsoever with respect to the sufficiency, accuracy or inadequacy of such information. It shall be the Bidder's responsibility to obtain detailed information from the respective utility companies relating to the location of their facilities and the work schedules of the utility companies for removing or adjusting them. Utilities whose facilities may be affected by the work include, but may not be limited to, the following: Nicor, ComEd, SBC, Comcast Cable, Downers Grove Sanitary District, and Village water, storm sewer, and street lighting systems.
- 2.5 No oral or telephone interpretations of specifications shall be binding upon the Village. All requests for interpretations or clarifications shall be made in writing and received by the Village at least five (5) business days prior to the date set for receipt of Bids or the pre-bid conference, if offered. The Village shall make all changes or interpretations of the Contract Documents in a written addendum and shall provide an addendum to any Bidder of record. Any and all changes to the Contract Documents are valid only if they are included by written addendum to all Bidders. Each Bidder must acknowledge receipt of any addenda by indicating same on the Bid Form. Each Bidder, by acknowledging receipt of any addenda, is responsible for the contents of the addenda and any changes to the Bid therein. Failure to acknowledge any addenda may cause the Bid to be rejected. The Village will not assume responsibility for receipt of any addenda. In all cases, it will be the Bidder's responsibility to obtain all addenda issued. Bidders will provide written acknowledgement of receipt of each addendum issued with the bid submission.

## Village of Downers Grove – S-008-23 ROW ACCESSIBILITY IMPROVEMENTS

- 2.6 An estimate of the quantities of Work to be performed and the materials to be furnished is shown in the Bid Form. It is given as a basis for comparing the properly submitted Bids, and shall be used by the Village in awarding the Contract. The Village does not expressly warrant nor imply that the estimated quantities shown will correspond with those quantities required to perform the Work. No Bidder shall plead misunderstanding or deception because of such an estimate of quantities, or because of the character, location or other conditions pertaining to the Work. Payment shall be based on the actual quantities of work properly performed in accordance with the Contract, at the Contract unit prices specified. The Village reserves the right to increase, decrease or omit entirely, any or all items. No allowance will be made for any change in anticipated profits due to an increase or decrease in the original estimate of quantities.
- 2.7 The Bid shall be executed properly, and Bids shall be made for all items indicated in the Bid Form. The Bidder shall indicate, in figures, a unit price or lump sum price for each of the separate items called for in the Bid Form. The Bidder shall show the products of the respective quantities and unit prices in the column provided for that purpose. The gross sum shown in the place indicated in the Bid Form shall be the summation of said products. All writing shall be with ink or typewriter, except the signature of the Bidder, which shall be written with ink.
- 2.8 In case of error in the extension of prices in the Bid, the hourly rate or unit price will govern. In case of discrepancy in the price between the written and numerical amounts, the written amount will govern.
- 2.9 All costs incurred in the preparation, submission, and/or presentation of any Bid including the Bidder's travel or personal expenses shall be the sole responsibility of the Bidder and will not be reimbursed by the Village.
- 2.10 The Bidder hereby affirms and states that the prices quoted herein constitute the total cost to the Village for all work involved in the respective items, as well as the materials to be furnished in accordance with the collective requirements of the Contract Documents. The Bidder also affirms that this cost includes all insurance, bonds, royalties, transportation charges, use of all tools and equipment, superintendence, overhead expense, profits and other work, services and conditions necessarily involved in the work to be done.
- 2.11 The Bidder shall complete and submit with the Bid an "Affidavit" (IDOT Form BC-57, or similar) listing all uncompleted contracts, including subcontract work; all pending low bids not yet awarded or rejected, and equipment available.
- 2.12 The Bidder shall complete and submit with the Bid a "Municipal Reference List" indicating other municipalities for which the Bidder has successfully performed similar work.
- 3. PRE-BID CONFERENCE**
- 3.1 A pre-bid conference may be offered to provide additional information, inspection or review of current facilities or equipment, and to provide an open forum for questions from Bidders. This pre-bid conference is not mandatory (unless stated "Mandatory" on the cover of this document), but attendance by Bidders is strongly advised as this will be the last opportunity to ask questions

## Village of Downers Grove – S-008-23 ROW ACCESSIBILITY IMPROVEMENTS

concerning the Bid.

3.2 Questions may be posed in writing to the Village (faxed and emailed questions are acceptable), but must be received by the Village prior to the scheduled time for the pre-bid conference. Questions received will be considered at the conference. An addendum may be issued as a result of the pre-bid conference. Such an addendum is subject to the provisions for issuance of an addendum as set forth in Section 2.5 above.

3.3 No Contract Documents will be issued after a mandatory pre-bid conference except to attendees.

#### **4. BID SUBMISSION**

4.1 An original copy of the sealed bid marked as indicated in Section 1 shall be submitted to the Village. Please do not bind any portion of the bid with staples.

4.2 A bid deposit will be required, which shall not exceed ten percent (10%) of the estimated cost of the work to be furnished. Such bid deposit shall be in the form of a bid bond, certified check, cash or money order. Checks shall be drawn upon a bank of good standing payable to the order of the Village and said deposit shall be forfeited to the Village in the event the Bidder neglects or refuses to enter into a contract and bond when required, with approved sureties, to execute the Work or furnish the material for the price mentioned in his Bid and according to the plans and specifications in case the contract shall be awarded to him.

4.3 Bids shall be publicly opened at the hour and place indicated above.

#### **5. BID MODIFICATION OR WITHDRAWAL**

5.1 A Bid that is in the possession of the Village may be altered by a letter bearing the signature of the person authorized for submitting a Bid, provided that it is received prior to the time and date set for the bid opening. Telephone, email or verbal alterations of a Bid will not be accepted.

5.2 A Bid that is in the possession of the Village may be withdrawn by the Bidder, up to the time set for the bid opening, by a letter bearing the signature of the person authorized for submitting Bids. Bids may not be withdrawn after the bid opening and shall remain valid for a period of ninety (90) days from the date set for the bid opening, unless otherwise specified.

#### **6. BID REJECTION**

6.1 Bids that contain omissions, erasures, alterations, additions not called for, conditional bids or alternate bids not called for, or irregularities of any kind, shall be rejected as informal or insufficient. Bids otherwise acceptable, which are not accompanied by the proper Proposal Guaranty, shall also be rejected as informal or insufficient. The Village reserves the right however, to reject any or all Bids and to waive such technical error as may be deemed best for the interest of the Village.

#### **7. BIDDER COMPETENCY**

7.1 No Bid will be accepted from, or contract awarded to, any person, firm or corporation that is in arrears or is in default upon any debt or contract. The Bidder, if requested, must present evidence to the Village of ability and possession of necessary facilities, and financial resources to comply with the terms of the Contract Documents. Evidence must be presented within three (3) business days.

Village of Downers Grove – S-008-23 ROW ACCESSIBILITY IMPROVEMENTS

**8. BIDDER DISQUALIFICATION**

8.1 Any one or more of the following causes may be considered as sufficient for the disqualification of a Bidder and the rejection of their Bid.

8.1.1 More than one Bid for the same Work from an individual, firm partnership, or corporation under the same or different names.

8.1.2 Evidence of collusion among Bidders.

8.1.3 Unbalanced Bids in which the prices for some items are substantially out of proportion to the prices for other items.

8.1.4 Failure to submit a unit price for each item of Work listed in the Bid Form.

8.1.5 Lack of competency as revealed by financial statement or experience questionnaire.

8.1.6 Unsatisfactory performance record as shown by past work, judged from the standpoint of workmanship and progress.

8.1.7 Uncompleted work which, in the judgment of the Village, might hinder or prevent the prompt completion of this Work.

8.1.8 Failure to submit a signed Bidder's Certificate stating the following:

8.1.8.1 That the Bidder is not barred from bidding on this Contract as a result of a violation of Sections 720 ILCS 5/33-E3 and 720 ILCS 5/33-E4 of the Illinois Compiled Statutes; and

8.1.8.2 The Bidder is not delinquent in the payment of any tax administered by the Illinois Department of Revenue; and

8.1.8.3 The Bidder will maintain the types and levels of insurance required by the terms of this Contract; and

8.1.8.4 The Bidder will comply with the Illinois Prevailing Wage Act, 820 ILCS 130/1 *et seq.*

**9. BASIS OF AWARD**

9.1 The Village reserves the exclusive right to accept or reject any and all Bids or to waive sections, technicalities and irregularities, or to accept or reject any Bid or any item of any Bid.

**10. AWARD OF CONTRACT**

10.1 Unless the Village exercises its right to reject all Bids, the Contract will be awarded to that responsible Bidder whose Bid, conforming to the Contract Documents, will be most advantageous to the Village, price and other factors considered (the credentials, financial information, bonding

## Village of Downers Grove – S-008-23 ROW ACCESSIBILITY IMPROVEMENTS

capacity, insurance protection, qualifications of the labor and management of the firm, past experience and ability to complete the project within time frame required - lowest responsible bidder).

- 10.2 Unless otherwise specified, if a Contract is not awarded within ninety (90) days after the opening of Bids, a Bidder may file a written request with the Village for the withdrawal of their Bid. The Village will have a maximum of ten (10) days after the receipt of such request to award the Contract or release the Bidder from further obligation by return of the Bidder's bid deposit. Any attempt or actual withdrawal or cancellation of a Bid by the awarded contractor who has been notified by the Village of the acceptance of said Bid shall be considered a breach of contract.

**11. RETURN OF BID DEPOSIT**

- 11.1 The bid deposit of all except the three (3) lowest responsive bidders on each contract will be returned within fifteen (15) days after the opening of Bids. The remaining bid deposits of each contractor will be returned within fifteen (15) days after the Village Council has awarded the contract and the required appurtenances to the contract have been received.

**12. FAILURE TO ENTER INTO CONTRACT**

- 12.1 Failure on the part of the successful Bidder to execute a Contract and provide acceptable bonds, as provided herein, within ten (10) days from the date of receipt of the Contract and Notice of Award from the Village, will be considered as just cause for the revocation of the award. The Bidder's bid security shall then be forfeited to the Village, not as a penalty, but in payment of liquidated damages sustained as a result of such failure.
- 12.2 Failure on the part of the successful Bidder to provide the Village a construction schedule for approval within ten (10) calendar days from the date of receipt of the Notice of Award from the Village, and, if required, provide a modified construction schedule as requested by the Village within an additional five (5) calendar days, may be considered as just cause for the revocation of the award. In such case, the Bidder's bid security shall then be forfeited to the Village, not as a penalty, but in payment of liquidated damages sustained as a result of such failure.
- 12.3 The Bidder shall not be allowed to claim lack of receipt where the Contract and Notice of Award was mailed by U.S. Postal Services certified mail to the business address listed in his Bid. In case the Village does not receive evidence of receipt within ten (10) days of the date of Notice of Award, the Village may revoke the award. The Bidder shall then forfeit the bid security to the Village, not as a penalty, but in payment of liquidated damages sustained as the result of such failure to execute the Contract.
- 12.4 By submitting a Bid, the Bidder understands and agrees that, if his Bid is accepted, and he fails to enter into a contract forthwith, he shall be liable to the Village for any damages the Village may thereby suffer.

**13. SECURITY FOR PERFORMANCE**

- 13.1 The successful Bidder shall, within ten (10) days after acceptance of the Bidder's Bid by the Village, furnish a Performance Bond and a Materials and Labor Payment Bond acceptable to the Village in the full amount of the Bid. Said bonds shall guarantee the Bidder's performance under the Contract Documents and shall guarantee payment of all subcontractors and material suppliers. Any bond shall

## Village of Downers Grove – S-008-23 ROW ACCESSIBILITY IMPROVEMENTS

include a provision that guarantees faithful performance of the Illinois Prevailing Wage Act, 820 ILCS 130/1 et seq.

**14. TAX EXEMPTION**

- 14.1 The Village is exempt from Illinois sales or use tax for direct purchases of materials and supplies. A copy of the Illinois Sales Tax Exemption Form will be issued upon request. The Village's federal identification number will also be provided to the selected Bidder.

**15. RESERVED RIGHTS**

- 15.1 The Village reserves the right to waive sections, irregularities, technicalities and informalities to this Contract and to accept any Bid and to reject any and all Bids and to disapprove of any and all subcontractors as may be in the best interest of the Village. Time and date requirements for receipt of Bids, however, will not be waived.

**16. CATALOGS AND SHOP DRAWINGS**

- 16.1 Each Bidder shall submit catalogs, descriptive literature, and detailed drawings, where applicable, to fully illustrate and describe the work or material he proposes to furnish.

**17. TRADE NAMES AND SUBSTITUTIONS**

- 17.1 Certain materials and equipment are specified by a manufacturer or trade name to establish standards or quality and performance and not for the purpose of limiting competition. Products of other manufacturers may be substituted, if, in the opinion of the Village, they are equal to those specified in quality, performance, design, and suitability for intended use. If the Bidder proposes to furnish an "equal", the proposed "equal" item must be so indicated in the written Bid. Where two or more items are specified, the selection among those specified is the Bidder's option, or he may submit his Bid on all such items. Detail specification sheets shall be provided by Bidder for all substituted items.

## Village of Downers Grove – S-008-23 ROW ACCESSIBILITY IMPROVEMENTS

**II. TERMS AND CONDITIONS****18. VILLAGE ORDINANCES**

- 18.1 The successful Bidder, now the Contractor, will strictly comply with all ordinances of the Village of Downers Grove and laws of the State of Illinois.

**19. USE OF VILLAGE'S NAME**

- 19.1 The Contractor is specifically denied the right of using in any form or medium the name of the Village for public advertising unless the Village grants express permission.

**20. HOURS OF WORK**

- 20.1 The Contractor shall do no work between the hours of 7:00 p.m. and 7:00 a.m., nor on Sundays or legal holidays. The Contractor shall do no work on Saturdays, unless otherwise approved in writing by the Village. If approved by the Village, allowed work hours on Saturdays shall be between the hours of 8:00 a.m. and 3:00 p.m. However, such work may be performed at any time if necessary, for the proper care and protection of work already performed, or in case of an emergency. All after-hour work is still subject to the permission of the Village. Any work, including the starting and/or idling of vehicles or machinery, or a congregation of workers prior to starting work, which may cause any noise level that can be heard by adjacent residents, performed outside of these hours of work and not authorized by the Village shall be subject to a fine of \$250 per day, per violation, which shall be deducted from the value of work completed.

**21. PERMITS AND LICENSES**

- 21.1 The Contractor shall obtain all necessary permits and licenses required to complete the Work. The cost of acquisition of all necessary permits, bonds, insurance and services as specified herein shall be considered INCLUDED IN THE TOTAL COST, and no additional compensation will be allowed the Contractor.

**22. INSPECTION**

- 22.1 The Village shall have a right to inspect, by its authorized representative, any material, components or workmanship as herein specified. Materials, components or workmanship that have been rejected by the Village as not in accordance with the terms of the contract specifications shall be replaced by the Contractor at no cost to the Village.

**23. DELIVERIES**

- 23.1 All materials shipped to the Village must be shipped F.O.B. designated location, Downers Grove, Illinois.

**24. SPECIAL HANDLING**

- 24.1 Prior to delivery of any product that is caustic, corrosive, flammable or dangerous to handle, the Contractor will provide written directions as to methods of handling such products, as well as the antidote or neutralizing material required for its first aid before delivery. Contractor shall also notify the Village and provide material safety data sheets for all substances used in connection with this Contract which are defined as toxic under the Illinois Toxic Substances Disclosure to Employees Act.

**25. NONDISCRIMINATION**

Village of Downers Grove – S-008-23 ROW ACCESSIBILITY IMPROVEMENTS

25.1 Contractor shall, as a party to a public contract:

25.1.1 Refrain from unlawful discrimination in employment and undertake affirmative action to assure equality of employment opportunity and eliminate the effects of past discrimination;

25.1.2 By submission of this Bid, the Contractor certifies that he is an "equal opportunity employer" as defined by Section 2000(e) of Chapter 21, Title 42, U.S. Code Annotated and Executive Orders #11246 and #11375, which are incorporated herein by reference. The Equal Opportunity clause, Section 6.1 of the Rules and Regulations of the Department of Human Rights of the State of Illinois, is a material part of any contract awarded on the basis of this Bid.

25.2 It is unlawful to discriminate on the basis of race, color, religion, sex, marital status, national origin or ancestry, age, physical or mental disability unrelated to ability, military status, order of protection status, sexual orientation, sexual identity, or an unfavorable discharge from military service. Contractor shall comply with standards set forth in Title VII of the Civil Rights Act of 1964, 42 U.S.C. Secs. 2000 et seq., The Human Rights Act of the State of Illinois, 775 ILCS 5/1-101 et seq., and The Americans with Disabilities Act, 42 U.S.C. Secs. 12101 et seq.

**26. SEXUAL HARASSMENT POLICY**

26.1 The Contractor, as a party to a public contract, shall have a written sexual harassment policy that:

26.1.1 Notes the illegality of sexual harassment;

26.1.2 Sets forth the State law definition of sexual harassment;

26.1.3 Describes sexual harassment utilizing examples;

26.1.4 Describes the Contractor's internal complaint process including penalties;

26.1.5 Describes the legal recourse, investigative and complaint process available through the Illinois Department of Human Rights and the Human Rights Commission and how to contact these entities; and

26.1.6 Describes the protection against retaliation afforded under the Illinois Human Rights Act.

**27. EQUAL EMPLOYMENT OPPORTUNITY**

27.1 In the event of the Contractor's non-compliance with the provisions of this Equal Employment Opportunity Clause, the Illinois Human Rights Act or the Rules and Regulations of the Illinois Department of Human Rights ("Department"), the Contractor may be declared ineligible for future contracts or subcontracts with the State of Illinois or any of its political subdivisions or municipal corporations, and the contract may be canceled or voided in whole or in part, and such other sanctions or penalties may be imposed or remedies invoked as provided by statute or regulation. During the performance of this Contract, the Contractor agrees as follows:

## Village of Downers Grove – S-008-23 ROW ACCESSIBILITY IMPROVEMENTS

- 27.1.1 That it will not discriminate against any employee or applicant for employment because of race, color, religion, sex, marital status, national origin or ancestry, age, physical or mental disability unrelated to ability, military status, order of protection status, sexual orientation, sexual identity, or an unfavorable discharge from military service; and further that it will examine all job classifications to determine if minority persons or women are underutilized and will take appropriate affirmative action to rectify any such underutilization.
- 27.1.2 That, if it hires additional employees in order to perform this Contract or any portion thereof, it will determine the availability (in accordance with the Department's Rules and Regulations) of minorities and women in the area(s) from which it may reasonably recruit and it will hire for each job classification for which employees are hired in such a way that minorities and women are not underutilized.
- 27.1.3 That, in all solicitations or advertisements for employees placed by it or on its behalf, it will state that all applicants will be afforded equal opportunity without discrimination because of race, color, religion, sex, marital status, national origin or ancestry, age, physical or mental disability unrelated to ability, military status, order of protection status, sexual orientation, or an unfavorable discharge from military services.
- 27.1.4 That it will send to each labor organization or representative of workers with which it has or is bound by a collective bargaining or other agreement or understanding, a notice advising such labor organization or representative of the Contractor's obligations under the Illinois Human Rights Act and the Department's Rules and Regulations. If any such labor organization or representative fails or refuses to cooperate with the Contractor in its efforts to comply with such Act and Rules and Regulations, the Contractor will promptly so notify the Department and the contracting agency and will recruit employees from other sources when necessary to fulfill its obligations thereunder.
- 27.1.5 That it will submit reports as required by the Department's Rules and Regulations, furnish all relevant information as may from time to time be requested by the Department or the contracting agency, and in all respects comply with the Illinois Human Rights Act and the Department's Rules and Regulations.
- 27.1.6 That it will permit access to all relevant books, records, accounts and work sites by personnel of the contracting agency and the Department for purpose of investigation to ascertain compliance with the Illinois Human Rights Act and the Department's Rules and Regulations.
- 27.1.7 That it will include verbatim or by reference the provisions of this clause in every subcontract it awards under which any portion of the contract obligations are undertaken or assumed, so that such provisions will be binding upon such subcontractor. In the same manner as with other provisions of this Contract, the Contractor will be liable for compliance with applicable provisions of this clause by such subcontractors; and further it will promptly notify the contracting agency and the Department in the event any subcontractor fails or refuses to comply therewith. In addition, the Contractor will not utilize any subcontractor declared by the Illinois Human Rights Commission to be ineligible for contracts or subcontracts with the State of Illinois or any of its political subdivision or municipal corporations.

Village of Downers Grove – S-008-23 ROW ACCESSIBILITY IMPROVEMENTS

**28. DRUG FREE WORK PLACE**

28.1 Contractor, as a party to a public contract, certifies and agrees that it will provide a drug free workplace by:

28.1.1 Publishing a statement:

(1) Notifying employees that the unlawful manufacture, distribution, dispensation, possession or use of a controlled substance, including cannabis, is prohibited in the Village's or Contractor's workplace.

(2) Specifying the actions that will be taken against employees for violations of such prohibition.

(3) Notifying the employee that, as a condition of employment on such contract or grant, the employee will:

(A) abide by the terms of the statement; and

(B) notify the employer of any criminal drug statute conviction for a violation occurring in the workplace no later than five (5) days after such conviction.

28.1.2 Establishing a drug free awareness program to inform employees about:

(1) the dangers of drug abuse in the workplace;

(2) the Village's or Contractor's policy of maintaining a drug free workplace;

(3) any available drug counseling, rehabilitation and employee assistance programs;

(4) the penalties that may be imposed upon employees for drug violations.

28.1.3 Providing a copy of the statement required by subparagraph 1.1 to each employee engaged in the performance of the contract or grant and to post the statement in a prominent place in the workplace.

28.1.4 Notifying the contracting or granting agency within ten (10) days after receiving notice under part (3)(B) of subparagraph 1.1 above from an employee or otherwise receiving actual notice of such conviction.

28.1.5 Imposing a sanction on, or requiring the satisfactory participation in a drug abuse assistance or rehabilitation program by, any employee who is so convicted as required by section 5 of the Drug Free Workplace Act.

28.1.6 Assisting employees in selecting a course of action in the event drug counseling, treatment and rehabilitation is required and indicating that a trained referral team is in place.

28.1.7 Making a good faith effort to continue to maintain a drug free workplace through implementation of the Drug Free Workplace Act.

**29. SUBSTANCE ABUSE PREVENTION ON PUBLIC WORKS PROJECTS ACT**

29.1 In the event this is a public works project as defined under the Prevailing Wage Act, 820 ILCS 130/2, Contractor agrees to comply with the Substance Abuse Prevention on Public Works Projects Act, 820 ILCS 265/1 *et seq.*, and further agrees that all of its subcontractors shall comply with such Act. As required by the Act, Contractor agrees that it will file with the Village prior to commencing work

## Village of Downers Grove – S-008-23 ROW ACCESSIBILITY IMPROVEMENTS

its written substance abuse prevention program and/or that of its subcontractor(s) which meet or exceed the requirements of the Act.

**30. PREVAILING WAGE ACT**

- 30.1 Contractor agrees to comply with the Illinois Prevailing Wage Act, 820 ILCS 130/1 et seq., for all work completed under this Contract. Contractor agrees to pay the prevailing wage and require that all of its subcontractors pay prevailing wage to any laborers, workers or mechanics who perform work pursuant to this Contract or related subcontract. For applicable rates, go to the State of Illinois – Department of Labor website ([www.state.il.us/agency/idol/rates/rates.HTM](http://www.state.il.us/agency/idol/rates/rates.HTM)) and use the most current DuPage County rate. The Department revises the prevailing wage rates and the Contractor or subcontractor has an obligation to check the Department's website for revisions to prevailing wage rates throughout the duration of this Contract.
- 30.2 Contractor and each subcontractor shall keep or cause to be kept accurate records of all laborers, mechanics and other workers employed by them on the public works project, which records must include each worker's name, address, telephone number when available, the last four digits of the worker's social security number, gender, race, ethnicity, veteran's status, skill level, classification, hourly wage paid (including itemized hourly cash and fringe benefits paid in each pay period), number of hours worked each day, the starting and ending times of work each day, the worker's hourly wage rate, the worker's hourly overtime wage rate, the worker's hourly fringe benefit rates, the name and address of each fringe benefit fund, the plan sponsor of each fringe benefit, if applicable, and the plan administrator of each fringe benefit, if applicable. These records shall be open to inspection at all reasonable hours by any representative of the Village or the Illinois Department of Labor (IDOL) and must be preserved for five (5) years from the date of the last payment on the public work.
- 30.3 Since this is a contract for a public works project, as defined in 820 ILCS 130/2, Contractor agrees to post at the job site in an easily accessible place, the prevailing wages for each craft or type of worker or mechanic needed to execute the contract or work to be performed.
- 30.4 Because this is a public works project as defined under the Prevailing Wage Act, 820 ILCS 130/2, any and all contractors and subcontractors shall submit certified payroll records to IDOL no later than the fifteenth (15th) day of each calendar month for the immediately preceding month in which construction on a public works project has occurred. Contractor shall then provide an IDOL certification and case number to the Village. **WITHOUT THIS PAPERWORK, NO INVOICE SHALL BE PAID BY THE VILLAGE.** Filing false records is a Class A misdemeanor.
- 30.5 In the event that this is a construction project where Motor Fuel tax monies or state grant monies are used in the construction, maintenance and extension of municipal streets, traffic control signals, street lighting systems, storm sewers, pedestrian subways or overhead crossings, sidewalks and off-street parking facilities, and the like, the Village will require an Apprenticeship and Training Certification, attached after the Bidder's Certification.
- 30.6 Any bond furnished as security for performance shall include a provision that guarantees faithful performance of the Illinois Prevailing Wage Act, 820 ILCS 130/1 et seq.

Village of Downers Grove – S-008-23 ROW ACCESSIBILITY IMPROVEMENTS

**31. PATRIOT ACT COMPLIANCE**

31.1 The Contractor represents and warrants to the Village that neither it nor any of its principals, shareholders, members, partners, or affiliates, as applicable, is a person or entity named as a Specially Designated National and Blocked Person (as defined in Presidential Executive Order 13224) and that it is not acting, directly or indirectly, for or on behalf of a Specially Designated National and Blocked Person. The Contractor further represents and warrants to the Village that the it and its principals, shareholders, members, partners, or affiliates, as applicable are not, directly or indirectly, engaged in, and are not facilitating, the transactions contemplated by this Contract on behalf of any person or entity named as a Specially Designated National and Blocked Person. The Contractor hereby agrees to defend, indemnify and hold harmless the Village, and its elected or appointed officers, employees, agents, representatives, engineers and attorneys, from and against any and all claims, damages, losses, risks, liabilities and expenses (including reasonable attorney’s fees and costs) arising from or related to any breach of the foregoing representations and warranties.

**32. INSURANCE REQUIREMENTS**

32.1 Prior to starting the Work, Contractor and any Subcontractors shall procure, maintain and pay for such insurance as will protect against claims for bodily injury or death, or for damage to property, including loss of use, which may arise out of operations by the Contractor or Subcontractor or any Sub-Sub Contractor or by anyone employed by any of them, or by anyone for whose acts any of them may be liable. Such insurance shall not be less than the greater of coverages and limits of liability specified below or any coverages and limits of liability specified in the Contract Documents or coverages and limits required by law unless otherwise agreed to by the Village.

Workers Compensation	\$500,000	Statutory
Employers Liability	\$1,000,000	Each Accident
	\$1,000,000	Disease Policy Limit
	\$1,000,000	Disease Each Employee
Comprehensive General Liability	\$2,000,000	Each Occurrence
	\$2,000,000	Aggregate
		<i>(Applicable on a Per Project Basis)</i>
Commercial Automobile Liability	\$1,000,000	Each Accident
Professional Errors & Omissions	\$2,000,000	Each Claim
(pursuant to section.9 below)	\$2,000,000	Annual Aggregate
Umbrella Liability	\$ 5,000,000	

32.2 Comprehensive General Liability Insurance required under this paragraph shall be written on an

## Village of Downers Grove – S-008-23 ROW ACCESSIBILITY IMPROVEMENTS

occurrence form and shall include coverage for Products/Completed Operations, Personal Injury with Employment Exclusion (if any) deleted, Blanket XCU and Blanket Contractual Liability insurance applicable to defense and indemnity obligations and other contractual indemnity assumed under the Contract Documents. The limit must be on a “Per Project Basis”.

- 32.3 Commercial Automobile Liability Insurance required under this paragraph shall include coverage for all owned, hired and non-owned automobiles.
- 32.4 Workers Compensation coverage shall include a waiver of subrogation against the Village.
- 32.5 Comprehensive General Liability, Employers Liability and Commercial Automobile Liability Insurance may be arranged under single policies for full minimum limits required, **or** by a combination of underlying policies with the balance provided by Umbrella and/or Excess Liability policies.
- 32.6 Contractor and all Subcontractors shall have their respective Comprehensive General Liability (including products/completed operations coverage), Employers Liability, Commercial Automobile Liability, and Umbrella/Excess Liability policies endorsed to add the “Village of Downers, its officers, officials, employees and volunteers” as “additional insureds” with respect to liability arising out of operations performed; claims for bodily injury or death brought against the Village by any Contractor or Subcontractor employees, or the employees of Subcontractor’s subcontractors of any tier, however caused, related to the performance of operations under the Contract Documents. Such insurance afforded to the Village shall be endorsed to provide that the insurance provided under each policy shall be ***Primary and Non-Contributory***.
- 32.7 Contractor and all Subcontractors shall maintain in effect all insurance coverages required by the Contract Documents at their sole expense and with insurance carriers licensed to do business in the State of Illinois and having a current A. M. Best rating of no less than A- VIII. In the event that the Contractor or any Subcontractor fails to procure or maintain any insurance required by the Contract Documents, the Village may, at its option, purchase such coverage and deduct the cost thereof from any monies due to the Contractor or Subcontractor, or withhold funds in an amount sufficient to protect the Village, or terminate this Contract pursuant to its terms.
- 32.8 All insurance policies shall contain a provision that coverages and limits afforded hereunder shall not be canceled, materially changed, non-renewed or restrictive modifications added, without thirty (30) days prior written notice to the Village. Renewal certificates shall be provided to the Village not less than five (5) days prior to the expiration date of any of the required policies. All Certificates of Insurance shall be in a form acceptable to the Village and shall provide satisfactory evidence of compliance with all insurance requirements. The Village shall not be obligated to review such certificates or other evidence of insurance, or to advise Contractor or Subcontractor of any deficiencies in such documents, and receipt thereof shall not relieve the Contractor or Subcontractor from, nor be deemed a waiver of the right to enforce the terms of the obligations hereunder. The Village shall have the right to examine any policy required and evidenced on the Certificate of Insurance.
- 32.9 If the Work under the Contract Documents includes design, consultation, or any other professional

## Village of Downers Grove – S-008-23 ROW ACCESSIBILITY IMPROVEMENTS

services, Contractor or the Subcontractor shall procure, maintain, and pay for Professional Errors and Omissions insurance with limits of not less than \$2,000,000 per claim and \$2,000,000 annual aggregate. If such insurance is written on a claim made basis, the retrospective date shall be prior to the start of the Work under the Contract Documents. Contractor and all Subcontractors agree to maintain such coverage for three (3) years after final acceptance of the Project by the Village or such longer period as the Contract Documents may require. Renewal policies during this period shall maintain the same retroactive date.

- 32.10 Any deductibles or self-insured retentions shall be the sole responsibility of the Insured. At the option of the Village, either: the insurer shall reduce or eliminate such deductibles or self-insured retentions as respects the Village, its officers, officials, employees and volunteers; or the Contractor shall procure a bond guaranteeing payment of losses and related investigations, claim administration and defense expenses.

**33. INDEMNITY AND HOLD HARMLESS AGREEMENT**

- 33.1 To the fullest extent permitted by law, the Contractor shall indemnify, keep and save harmless the Village and its agents, officers, and employees, against all injuries, deaths, strikes, losses, damages, claims, suits, liabilities, judgments, costs and expenses, which may arise directly or indirectly from any negligence or from the reckless or willful misconduct of the Contractor, its employees, or its subcontractors.

- 33.2 The Contractor shall, at its own expense, appear, defend and pay all charges of attorneys and all costs and other expenses arising therefrom or incurred in connection therewith, and, if any judgment shall be rendered against the Village in any such action, the Contractor shall, at its own expense, satisfy and discharge the same. This agreement shall not be construed as requiring the Contractor to indemnify the Village for its own negligence. The Contractor shall indemnify, keep and save harmless the Village only where a loss was caused by the negligent, willful or reckless acts or omissions of the Contractor, its employees, or its subcontractors.

**34. SUBLETTING OF CONTRACT**

- 34.1 No contract awarded by the Village shall be assigned or any part subcontracted without the written consent of the Village. In no case shall such consent relieve the Contractor from his obligation or change the terms of this Contract.

All approved subcontracts shall contain language which incorporates the terms and conditions of this Contract.

**35. TERMINATION OF CONTRACT**

- 35.1 The Village reserves the right to terminate the whole or any part of this Contract, upon written notice to the Contractor, for any reason.

- 35.2 The Village further reserves the right to terminate the whole or any part of this Contract, upon written notice to the Contractor, in the event of default by the Contractor. Default is defined as failure of the Contractor to perform any of the provisions of this Contract or failure to make sufficient progress so as to endanger performance of this Contract in accordance with its terms. In the event that the Contractor fails to cure the default upon notice, and the Village declares default and termination, the

## Village of Downers Grove – S-008-23 ROW ACCESSIBILITY IMPROVEMENTS

Village may procure, upon such terms and in such manner as it may deem appropriate, supplies or services similar to those so terminated. The Village may also contact the issuer of the Performance Bond to complete the Work. The Contractor shall be liable for any excess costs for such similar supplies or services. Any such excess costs incurred by the Village may be set-off against any monies due and owing by the Village to the Contractor.

**36. BILLING AND PAYMENT PROCEDURES**

- 36.1 Payment will be made upon receipt of an invoice referencing Village purchase order number. Once an invoice and receipt of materials or service have been verified, the invoice will be processed for payment in accordance with the Village's payment schedule. The Village will comply with the Local Government Prompt Payment Act, 50 ILCS 505/1 et seq., in that any bill approved for payment must be paid or the payment issued to the Contractor within 60 days of receipt of a proper bill or invoice. If payment is not issued to the Contractor within this 60-day period, an interest penalty of 1.0% of any amount approved and unpaid shall be added for each month or fraction thereof after the end of this 60-day period, until final payment is made.
- 36.2 The Village shall review each bill or invoice in a timely manner after its receipt. If the Village determines that the bill or invoice contains a defect making it unable to process the payment request, the Village shall notify the Contractor as soon as possible after discovering the defect pursuant to rules promulgated under 50 ILCS 505/1 et seq. The notice shall identify the defect and any additional information necessary to correct it.
- 36.3 As this Contract is for work defined as a "fixed public work" project under the Illinois Prevailing Wage Act, 820 ILCS 130/2 and pursuant to section 30.4 of this Call For Bid, the Contractor shall provide an IDOL certification and case number to the Village along with the invoice. No invoice shall be paid without said records.
- 36.4 Please send all invoices to the attention of: Village of Downers Grove, Public Works, 5101 Walnut Ave., Downers Grove, IL 60515.

**37. COMPLIANCE WITH OSHA STANDARDS**

- 37.1 Equipment supplied to the Village must comply with all requirements and standards as specified by the Occupational Safety and Health Act. All guards and protectors as well as appropriate markings will be in place before delivery. Items not meeting any OSHA specifications will be refused.

**38. CERCLA INDEMNIFICATION**

- 38.1 The Contractor shall, to the maximum extent permitted by law, indemnify, defend, and hold harmless the Village, its officers, employees, agents, and attorneys from and against any and all liability, including without limitation, costs of response, removal, remediation, investigation, property damage, personal injury, damage to natural resources, health assessments, health settlements, attorneys' fees, and other related transaction costs arising under the Comprehensive Environmental Response, Compensation, and Liability Act (CERCLA) of 1980, 42 U.S.C.A. Sec. 9601, et seq., as amended, and all other applicable statutes, regulations, ordinances, and under common law for any release or threatened release of the waste material collected by the Contractor, both before and after its disposal.
- 38.2 If the Contractor encounters any waste material governed by the above Act, it shall immediately

## Village of Downers Grove – S-008-23 ROW ACCESSIBILITY IMPROVEMENTS

notify the Village and stop working in the area until the above requirements can be met.

**39. COPYRIGHT or PATENT INFRINGEMENT**

39.1 The Contractor agrees to indemnify, defend, and hold harmless the Village against any suit, claim, or proceeding brought against the Village for alleged use of any equipment, systems, or services provided by the Contractor that constitutes a misuse of any proprietary or trade secret information or an infringement of any patent or copyright.

**40. BUY AMERICA**

40.1 The Contractor agrees to comply with 49 U.S.C.5323(j), the Federal Transportation Administration's (FTA) Buy America regulations at 49 C.F.R. Part 661, and any amendments thereto, and any implementing guidance issued by the FTA, with respect to this Contract, when financed by Federal funds (through a grant agreement or cooperative agreement).

40.2 As a condition of responsiveness, the Contractor agrees to submit with its Bid submission, an executed Buy America Certificate, attached hereto.

**41. CAMPAIGN DISCLOSURE**

41.1 Any contractor, proposer, bidder or vendor who responds by submitting a bid or proposal to the Village of Downers Grove shall be required to submit with its bid submission, an executed Campaign Disclosure Certificate, attached hereto.

41.2 The Campaign Disclosure Certificate is required pursuant to the Village of Downers Grove Council Policy on Ethical Standards and is applicable to those campaign contributions made to any member of the Village Council.

41.3 Said Campaign Disclosure Certificate requires any individual or entity bidding to disclose campaign contributions, as defined in Section 9-1.4 of the Election Code (10 ILCS 5/9-1.4), made to current members of the Village Council within the five (5) year period preceding the date of the bid or proposal release.

41.4 By signing the bid documents, contractor/proposer/bidder/vendor agrees to refrain from making any campaign contributions as defined in Section 9-1.4 of the Election Code (10 ILCS 5/9-1.4) to any Village Council member and any challengers seeking to serve as a member of the Downers Grove Village Council.

**42. GUARANTEE PERIOD**

42.1 The Contractor shall guarantee all work and provide a maintenance bond for the full amount of the contract, covering a minimum period of one (1) year after approval and acceptance of the Work. The bond shall be in such form as the Village may prescribe, unless otherwise noted in the Specifications, and shall be submitted before receiving final payment. If longer guarantee periods are required, they will be noted in the Special Provisions for this project.

**43. SUCCESSORS AND ASSIGNS**

43.1 The terms of this Contract will be binding upon and inure to the benefit of the parties and their respective successors and assigns; provided, however, that neither party will assign this Contract in

## Village of Downers Grove – S-008-23 ROW ACCESSIBILITY IMPROVEMENTS

whole or in part without the prior written approval of the other. The Contractor will provide a list of key staff, titles, responsibilities, and contact information to include all expected subcontractors.

**44. WAIVER OF BREACH OF CONTRACT**

44.1 The waiver by one party of any breach of this Contract or the failure of one party to enforce at any time, or for any period of time, any of the provisions hereof will be limited to the particular instance and will not operate or be deemed to waive any future breaches of this Contract and will not be construed to be a waiver of any provision except for the particular instance.

**45. CHANGE ORDERS**

45.1 The contract price is a “not-to-exceed” cost. At any time additional work is necessary or requested, and the not-to-exceed price is increased thereby, all parties must agree to any change, addition or price increase in writing.

45.2 Change orders for public works projects which authorize an increase in the contract price that is 50% or more of the original contract price or that authorize or necessitate any increase in the price of a subcontract under the contract that is 50% or more of the original subcontract price must be resubmitted for bidding in the same manner by which the original contract was bid. (50 ILCS 525/1)

**46. SEVERABILITY OF INVALID PROVISIONS**

46.1 If any provisions of this Contract are held to contravene or be invalid under the laws of any state, country or jurisdiction, contravention will not invalidate the entire Contract, but it will be construed as if not containing the invalid provision and the rights or obligations of the parties will be construed and enforced accordingly.

**47. GOVERNING LAW AND VENUE**

47.1 This Contract will be governed by and construed in accordance with the laws of the State of Illinois. Venue is proper only in the County of DuPage for state cases or the Northern District of Illinois for federal cases.

**48. NOTICE**

48.1 Any notice will be in writing and will be deemed to be effectively served when deposited in the mail with sufficient first class postage affixed, and addressed to the party at the party's place of business. Notices shall be addressed to the Village as follows:

**Village Manager  
Village of Downers Grove  
801 Burlington Ave.  
Downers Grove, IL 60515**

And to the Contractor as designated on the Contract Form.

**49. AMENDMENT**

49.1 This Contract will not be subject to amendment unless made in writing and signed by all parties.

**50. COOPERATION WITH FOIA COMPLIANCE**

## Village of Downers Grove – S-008-23 ROW ACCESSIBILITY IMPROVEMENTS

- 50.1 Contractor acknowledges that the Freedom of Information Act does apply to public records in possession of the Contractor or a subcontractor. Contractor and all of its subcontractors shall cooperate with the Village in its efforts to comply with the Freedom of Information Act. 5 ILCS 140/1 et seq.
- 51. EMPLOYMENT OF ILLINOIS WORKERS ON PUBLIC WORKS ACT**
- 51.1 If the work contemplated by this Contract is funded or financed in whole or in part with State Funds or funds administered by the State, Contractor agrees to comply with the terms of the Employment of Illinois Workers on Public Works Act by employing at least 90% Illinois laborers on the project. 30 ILCS 570/1 et seq. Contractor agrees further to require compliance with this Act by all of its subcontractors.
- 52. DISADVANTAGED BUSINESS ENTERPRISE (DBE) CERTIFICATION**
- Pursuant to 35 ILCS 200/18-50.2, Contractor and all subcontractors are required to complete and submit a Vendor DBE certification, regardless of DBE status. Contractor shall complete and require all its subcontractors to complete the DBE certification for this project at [www.downers.us/vss](http://www.downers.us/vss). The information necessary for the Contractor and all subcontractors to complete the certification includes the following: DBE Classification (minority-owned, women-owned, persons with disabilities-owned, veteran-owned, or none); if DBE, whether the company holds a certificate or self-certifies; if self-certifying, whether the company qualifies as a small business under the U.S. Small Business Administration standards; the company's name, address, city, state and zip code; company's contact person's name, title, telephone number and email address. **NO PAYMENTS WILL BE MADE TO THE CONTRACTOR BY THE VILLAGE UNLESS AND UNTIL ALL OF THE CERTIFICATIONS FOR THE CONTRACTOR AND SUBCONTRACTORS HAVE BEEN COMPLETED.**

## Village of Downers Grove – S-008-23 ROW ACCESSIBILITY IMPROVEMENTS

**III. GENERAL PROVISIONS****1. STANDARD SPECIFICATIONS**

- 1.1 The following standards shall govern the construction of the proposed improvements:
- 1.1.1 Standard Specifications for Water and Sewer Main Construction in Illinois, Seventh Edition, 2014 (the Water & Sewer Specs.); and
- 1.1.2 Standard Specifications for Road and Bridge Construction as adopted by the Illinois Department of Transportation, January 1, 2022; along with Supplemental Specifications and Recurring Special Provisions as adopted by the Illinois Department of Transportation, January 1, 2022 (collectively the “SSRBC”); and
- 1.1.3 Water Distribution Specifications, Village of Downers Grove, Illinois, revised January 2017.
- 1.1.4 Standard Detail Drawings, Village of Downers Grove, Illinois revised January, 2019.
- 1.2 These Contract Documents shall take precedence whenever there are conflicts in the wording or statements made by the above specifications and these Contract Documents.
- 1.3 Unless otherwise referenced herein, Division I of the Water and Sewer Specs and Section 102 and Articles 104.03, 104.07, 107.02, 107.27, 107.35, 108.10, 108.11, and 108.12 of the SSRBC are hereby ineffective and not a part of this Contract.

**2. COOPERATION OF CONTRACTOR**

- 2.1 The Contractor will be supplied with a minimum of 2 sets of approved plans and contract assemblies including Special Provisions, one set of which the Contractor shall keep available on the work site at all times. The Contractor shall give the work site constant attention necessary to facilitate the progress thereof, and shall cooperate with the Village in every way possible.
- 2.2 The Contractor shall assign a superintendent for the work per Sections 105.06 and 108.06 of the SSRBC and as amended herein. The Contractor’s superintendent shall be involved in the work to the extent necessary to prosecute the work per the Contract. Furthermore, the superintendent shall be required to attend weekly progress meetings, provide two-week schedules of expected construction activities, provide updated overall construction schedules and, if required by the Engineer, acknowledge and sign IDOT Form BC-239 Weekly Report of Resident. The Contractor shall not replace the superintendent without prior written notification to the Village.

**3. LEGAL REGULATIONS AND RESPONSIBILITY TO THE PUBLIC**

- 3.1 Section 107 of the SSRBC shall govern the Contractor’s legal regulations and responsibility to the public, with the following additions:
- 3.1.1 **PROJECT SAFETY.** Add the following to Article 107.28:
- 3.1.1.1 The Contractor shall conduct his work in such a manner as to provide an environment consistent with the safety, health and well being of those engaged in

## Village of Downers Grove – S-008-23 ROW ACCESSIBILITY IMPROVEMENTS

the completion of the Work specified in this Contract.

- 3.1.1.2 The Contractor shall comply with all State and Federal Safety Regulations as outlined in the latest revisions of the Federal Construction Safety Standards (Series 1926) and with applicable provisions and/or regulations of the Occupation Safety and Health Administration (OSHA) and Standards of the Williams-Stelger Occupational Health Safety Act of 1970 (Revised). SPECIAL ATTENTION SHALL BE PAID TO COMPLIANCE WITH OSHA'S SUBPART P – EXCAVATIONS STANDARD.
- 3.1.1.3 The Contractor and Village shall each be responsible for their own respective agents and employees.
- 3.1.1.4 The Contractor shall, prior to performing any work, request information from the Village regarding any existing confined spaces owned by the Village that may be entered in the course of the work, and shall obtain all required confined space entry permits prior to entering any confined spaces. Contractor shall follow all current laws and regulations with regard to confined space entry. Contractor shall maintain and, upon request, provide full documentation of compliance with the appropriate confined space permits for each separate confined space entered on the project.
- 3.1.2 **BACKING PRECAUTIONS.** Pursuant to Sections 14-139(b) and 14-171.1 of the Downers Grove Municipal Code, any motor vehicle which has an obstructed view to the rear and is to be operated at any time in reverse gear on the public streets of the Village by the Contractor or any subcontractor shall either be equipped with a reverse signal alarm (backup alarm) audible above and distinguishable from the surrounding noise level, or shall provide an observer to signal that it is safe to back up.
- 3.1.3 **OVERWEIGHT, OVERWIDTH AND OVERHEIGHT PERMITS.** The Village has and supports an overweight truck enforcement program. Contractors are required to comply with weight requirements and safety requirements as established by Illinois Law or Village Ordinance, for vehicles, vehicle operators and specialty equipment. In some instances, specialty equipment for road repairs or construction projects requires the movement of overweight, overwidth, or overheight loads utilizing a Village roadway. Such movement will require obtaining a permit from the Village Police Department's Traffic Supervisor.
- 3.1.4 **BARRICADES AND WARNING SIGNS.** The Contractor shall provide the Village with a telephone number of a person or company who is available 24 hours per day, seven days per week, to erect additional barricades or signs. If the Village or its representative deems it necessary for the Public's safety to erect additional barricades or signs during normal working hours, the Contractor will furnish the necessary barricades or signs, and have them in place within 30 minutes. If, after normal working hours, the requested signs are not in place within three hours after the request is made, the Village reserves the right to have the barricades and signs erected. The cost of erecting the barricades and signs shall be deducted by the Village from any payments due the Contractor.

## Village of Downers Grove – S-008-23 ROW ACCESSIBILITY IMPROVEMENTS

**4. PROSECUTION AND PROGRESS**

- 4.1 Section 108 of the SSRBC shall govern the prosecution and progress of the work, with the following additions:
- 4.1.1 The Contractor shall schedule his work such that all improvements shall be complete by **Friday, July 21, 2023**. The completion date will remain binding throughout the duration of the Contract unless revised in writing by the Village.
- 4.1.2 The total duration of disturbance for work related to means of public egress through the project site or access to private property (e.g. removal and replacement of curb and gutters, sidewalks, driveway entrances, etc.) must not exceed ten (10) calendar days. The Contractor may use high-early strength concrete, meeting all specifications herein, **at his own expense** to help meet this requirement.
- 4.1.3 The Contractor shall also make special note of the following work schedule requirements:
- 4.1.3.1.1 No work shall begin on Prairie Avenue prior to **Thursday, June 8, 2023**.
- 4.1.3.1.2 Work for locations on Prairie Avenue shall be phased as follows:
- Phase 1:
    - northwest corner of Prairie and Pershing (BID 1)
    - northeast corner of Prairie and Linscott (BID 2)
    - southeast corner of Prairie and Forest (BID 6)
  - Phase 2:
    - northwest corner of Prairie and Linscott (BID 3)
    - southwest corner of Prairie and Prince (BID 4)
    - northwest corner of Prairie and Forest (BID 5)
- 4.1.4 Should the Contractor fail to complete the work on or before the specified completion dates set forth in Sections 4.1.1, 4.1.2, 4.1.3, or within such extended time as may be allowed, the Contractor shall be liable for liquidated damages in accordance with the applicable sections of Article 108.09 of the SSRBC. In addition, the Contractor shall be liable for additional costs incurred by the Village due to the delay for construction engineering services, which shall be deducted from the value of work completed.
- 4.1.5 Upon substantial completion of the project, the Engineer will deliver to the Contractor a punch list as well as a due date for completion of the punch list. If the Contractor fails to complete the punch list by the stated punch list completion date, the Contractor shall be liable for liquidated damages in accordance with the applicable sections of Article 108.09 of the SSRBC.
- 4.1.5 Prior to commencing construction, a meeting will be held with the Contractor and the Village. Any questions concerning procedures, general conditions, special provisions, plans or specific items related to the project shall be answered and clarified. No Pre-Construction meeting shall be scheduled until submittals, performance bonds, and certificates of insurance are delivered to, and approved by, the Village.

## Village of Downers Grove – S-008-23 ROW ACCESSIBILITY IMPROVEMENTS

- 4.1.6 Weekly progress meetings may be required by the Village. If required, the Contractor shall have a capable person, such as a site superintendent or project manager, attend such meetings and be prepared to report on the prosecution of the Work according to the progress schedule. The Village reserves the right to require adjustments to scheduling of work.

### 5. MEASUREMENT AND PAYMENT

- 5.1 Section 109 of the SSRBC shall govern measurement and payment, with the following additions:

- 5.1.1 Modifies Article 109.07 - Partial payments will be made per Section 36 of Part II of this document (Billing and Payment Procedures.)
- 5.1.2 The Village will require that partial and final affidavits for all labor, materials and equipment used on the Project and certified payroll records, be submitted with the partial and final payment requests. Such waivers shall indicate that charges for all labor, materials and equipment used on the project have been paid. Partial waivers from suppliers and subcontractors may be submitted after the first payment to the Contractor, and before the subsequent payment to that which they apply. However, partial waivers from the Contractor must accompany the invoice of the payment to which it applies. All final waivers, from all suppliers and subcontractors MUST accompany the Contractor's invoice upon submittal for final payment. A sworn statement by the Contractor shall accompany full waivers. Such requirement for full waivers is solely for the benefit of the Village and shall not be construed to benefit any other person. Partial payment for work done shall in no way imply acceptance of the work to that date.
- 5.1.3 For each progress payment made to the Contractor prior to acceptance of the Work by the Village, the Village shall have the right to retain ten percent (10%) of the amount due to the Contractor for each such payment. The Village may, in its sole discretion, reduce the amount to be retained at any time.

Typically, upon completion of 50% of the work, as determined by the Engineer, retainage may be reduced to 5%. Upon substantial completion, as determined by the Engineer, retainage may be reduced to 2%. Additionally, the Village has the right to withhold an amount of money equivalent to complete unfinished work and/or work that may need to be redone.

### 6. SCOPE OF WORK

- 6.1 In addition to the Special Provisions in the Detailed Specifications Section below, Section 104 of the SSRBC shall govern scope of work, with the following revisions:

- 6.1.1 Modify Article 104.02 as follows:

#### **104.02 Alterations, Cancellations, Extensions, Deductions, and Extra Work.**

The Department reserves the right to make, in writing, at any time during work, changes in quantities, alterations in work, and the performance of extra work to satisfactorily complete the project. Such changes in quantities, alterations, and extra work shall not invalidate the contract nor release the surety, and the Contractor agrees to perform the work as altered.

## Village of Downers Grove – S-008-23 ROW ACCESSIBILITY IMPROVEMENTS

If the alterations or changes in quantities significantly change the character of the work under the contract, whether or not changed by any such different quantities or alterations, an adjustment, excluding loss of anticipated profits, will be made to the contract. The basis for the adjustment shall be agreed upon prior to the performance of the work. If a basis cannot be agreed upon, then an adjustment will be made either for or against the Contractor in such amount as the Engineer may determine to be fair and equitable.

If alterations or changes in quantities do not significantly change the character of the work to be performed under contract, the altered work will be paid for as provided elsewhere in the contract. The term “significant change” shall be construed to apply only when the character of the work as altered differs materially in kind or nature from that involved or included in the original proposed construction ~~or when a major item, defined as an item whose total original contract cost plus any additions exceeds ten percent of the total original contract amount, is increased in excess of 125 percent or decreased below 75 percent of the original contract quantity.~~

All alterations, cancellations, extensions, and deductions shall be authorized in writing by the Engineer before work is started. Such authorizations shall set up the items of work involved and the method of payment for each item. The Contractor shall accept payment for alterations which result in an increase or decrease in the quantities of work to be performed according to the following.

(a) All increases in work of the type which appear in the contract as pay items accompanied by unit prices will, except as provided under paragraph (d) herein, be paid for at the contract unit prices. Decreases in quantities included in the contract will be deducted from the contract at the unit bid prices. No allowance will be made for delays or anticipated profits.

(b) Major items of work for which the quantities are increased ~~by not more than 125 percent~~ ~~or reduced to not less than 75 percent of the original contract quantities~~ OR DECREASED will be paid for as specified in paragraph (a) above. ~~Any adjustments for increased quantities for major items of work increased more than 125 percent shall only apply to that portion in excess of 125 percent of original contract quantities. Any adjustments made for major items of work which are decreased to less than 75 percent of the original contract quantities shall apply to the actual amount of work performed.~~

(c) Extra work which is not included in the contract as pay items at unit prices and is not included in other items of the contract will be paid for according to Article 109.04.

(d) Extra work for which there is a pay item at unit price in the contract which for any one or more of the following reasons materially increases or decreases the cost of the pay item as bid and which is not included in the prices bid for other items in the contract will be paid for according to Article 109.04. This includes:

- (1) Work involving a substantial change of location.
- (2) Work which differs in design.
- (3) Work requiring a change in the type of construction.

(e) In cases where the Department cancels or alters any portion of the contract items, items which are partially completed will be paid for as specified in Article 109.06.

Claims for extra work which have not been authorized in writing by the Engineer will be

Village of Downers Grove – S-008-23 ROW ACCESSIBILITY IMPROVEMENTS

rejected.

## Village of Downers Grove – S-008-23 ROW ACCESSIBILITY IMPROVEMENTS

**IV. SPECIAL PROVISIONS**

The following Special Provisions shall modify, supersede, or supplement the Standard Specifications referred to in Section III - General Provisions.

Where any section, subsection, paragraph, or subparagraph of the Standard Specifications is *supplemented* by any of the following paragraphs, the provisions of such section, subsection, paragraph, or subparagraph shall remain in effect. The Special Provisions shall govern in addition to the particular Standard Specification so supplemented, and not in lieu thereof.

Where any section, subsection, paragraph, or subparagraph of the Standard Specifications is *amended, voided, or superseded* by any of the following paragraphs, any provision of such section, subsection, paragraph, or subparagraph standing unaffected, shall remain in effect. The Special Provisions shall govern in lieu of any particular provision of the Standard Specification so amended, voided, or superseded, and not in addition to the portion changed.

**SP-1 SCOPE OF WORK**

The 2023 Right of Way Accessibility Improvement project shall generally consist of the following:

1. Sidewalk ramp upgrades at the northwest corner of Prairie and Pershing (BID 1)
2. Sidewalk ramp upgrades at the northeast corner of Prairie and Linscott (BID 2)
3. Sidewalk ramp upgrades at the northwest corner of Prairie and Linscott (BID 3)
4. Sidewalk ramp upgrades at the southwest corner of Prairie and Prince (BID 4)
5. Sidewalk ramp upgrades at the northwest corner of Prairie and Forest (BID 5)
6. Sidewalk ramp upgrades at the southeast corner of Prairie and Forest (BID 6)
7. Sidewalk ramp upgrades at the southwest corner of Hatch and Camden (BID 7)
8. Sidewalk ramp upgrades at the northeast corner of Hall and Devereux (BID 8)
9. Sidewalk ramp upgrades at the northeast corner of Borman and Devereux (BID 9)
10. Sidewalk ramp upgrades at the northeast corner of Klein and Barrett (BID 10)
11. Sidewalk ramp upgrades at the northeast corner of Lane and Summit (BID 11)
12. Sidewalk ramp upgrades at the northwest corner of Chicago and Saratoga (BID 12)
13. Sidewalk ramp upgrades at the northeast corner of 7<sup>th</sup> and Fairview (BID 13)
14. Sidewalk ramp upgrades at the southeast corner of 7<sup>th</sup> and Fairview (BID 14)
15. Sidewalk ramp upgrades at the northeast corner of Venard and Red Bud (BID ALT)

The project generally consists of the installation of approximately 5,000 square feet of 5" thick P.C.C. sidewalk, earth excavation, combination concrete curb and gutter removal and replacement, concrete barrier curb installation, modular block retaining wall installation, tree removal, all collateral work, and related grading and parkway and road restoration.

All work must comply with the latest requirements of the Americans with Disabilities Act (ADA), Public Right-of-Way Accessibility Guidelines (PROWAG), the Illinois Accessibility Code (IAC) and Manual on Uniform Traffic Control Devices (MUTCD).

## Village of Downers Grove – S-008-23 ROW ACCESSIBILITY IMPROVEMENTS

The Village reserve the right to award based on any bid, combination of bids or all bids, whatever is deemed to be in the best interest of the Village.

### SP-2 GENERAL CONSTRUCTION REQUIREMENTS

The following general requirements are intended to govern the overall priority for the performance of the work described in this contract. As general requirements, they are not intended to dictate to the Contractor the precise method by which these tasks shall be performed.

No more than three hundred linear feet (300 LF) of pavement may be open-cut and closed to use by the motoring public. Access to all individual drives within the current work zone must be restored at the end of each workday except when access is subject to placement of and curing of concrete pavement, sidewalk and/or curb and gutter. In such case, the Contractor shall provide the Engineer a daily schedule of construction activities impacting access.

The Contractor shall maintain traffic flow on ALL STREETS during the day in accordance with the applicable special provision, unless stated otherwise by a Village-approved traffic control plan. Adequate signing and flagging is of particular importance for safe travel of all residents.

#### Protection of Work

The Contractor shall be responsible to provide personnel to protect his work from third party damage. Should any of the new work be damaged, it shall be removed and replaced at the Contractor's expense. The Contractor shall schedule his work so that the concrete placed, takes its initial set during daylight hours. Claims of darkness shall not be reason to relieve the Contractor from responsibility.

#### Cleaning Up

The Contractor shall, at all times, keep the premises free from an accumulation of waste material or rubbish caused by his employees or work. At the end of the day, he shall remove all his rubbish from and about the streets and sidewalks. All his tools, form boards, and surplus materials shall be removed and relocated to any temporary on-site storage location assigned by the Village or its Engineer, and shall leave his work "broom clean" or its equivalent, unless more precisely defined. Upon completion of the work called for by the contract, and upon final inspection and acceptance, the Contractor shall remove any of his remaining rubbish, tools, form boards, and surplus materials completely from the work site.

In case of dispute, the Village may remove the rubbish and any other materials and charge the cost to the Contractor.

### SP-3 ACCESS AND WATER SHUT-OFF NOTIFICATION

**Description:** If access to a driveway will be blocked, or water will be turned off, the Contractor shall give that resident or business proper written notification at least 24 hours in advance. The Contractor must provide them the opportunity to remove their cars from the drive or make other arrangements, and prepare for any shutdown of the water system. Samples of written notices shall be submitted to the Engineer for approval.

In addition, the Contractor shall be responsible for notifying the resident or business verbally on the morning of any driveway closure, to ensure awareness of the lack of access.

**Basis of Payment:** This work shall be considered **INCIDENTAL** to the project.

Village of Downers Grove – S-008-23 ROW ACCESSIBILITY IMPROVEMENTS

**SP-4 STATUS OF UTILITIES**

Effective: May 1, 2023

Revised: N/A

Utility companies and/or municipal owners located within the construction limits of this project have provided the following information regarding their facilities and the proposed improvements. The tables below contain a description of specific conflicts to be resolved and/or facilities which will require some action on the part of the Contractor to proceed with work. Each table entry includes an identification of the action necessary and, if applicable, the estimated duration required for the resolution.

Utilities to be adjusted

Conflicts noted below have been identified. The owner of the utility has been notified of all conflicts and will be required to obtain the necessary permits to complete their work; in some instances, resolution will be a function of the construction staging. The owner of the utility must relocate, or complete new installations as noted below; this work has been deemed necessary for the Village’s Contractor to complete the improvements.

Location	Type	Description	Owner	Duration of Time	Responsible Agency for Resolution
Prairie and Forest – SE	Communication Manhole	Manhole Adjustment	Paetec	2 days	Downers Grove
Prairie and Forest – SE	Communication Handhole	Handhole Adjustment	Paetec	2 days	Downers Grove

Utilities to be watched and protected

The information provided is not a comprehensive list of all remaining utilities, but those which during coordination were identified as ones which might require the Contractor to take into consideration when making the determination of the means and methods that would be required to construct the proposed improvement. In some cases, the Contractor will be responsible to notify the utility owner in advance of the work to take place so necessary staffing on the utility owner’s part can be secured.

Location	Type	Description	Owner

The following contact information is what was used during the preparation of the plans as provided by the owner of the utility.

Agency/Company Responsible to Resolve Conflict	Name of contact	Phone	E-mail address
Downers Grove	Matt Stern	(630) 434-5463	<a href="mailto:mstern@downers.us">mstern@downers.us</a>

## Village of Downers Grove – S-008-23 ROW ACCESSIBILITY IMPROVEMENTS

The above represents the best information available to the Village and is included for the convenience of the Contractor. The Contractor is responsible for contacting J.U.L.I.E. prior to all excavation work. The Contractor is also responsible for investigating/verifying any and all potential conflicts with existing utilities per special provision for EXPLORATORY TRENCH, SPECIAL.

### **SP-5 PRECONSTRUCTION VIDEOTAPING**

**Description:** This work shall consist of furnishing all materials and labor required to perform a videotape survey of the construction limits, adjacent right-of-way, and adjacent structures bordering the work. This shall include, but not be limited to, existing buildings, garages, pavements, curb and gutter, sidewalks, fences, trees and landscaping. Two (2) copies of the videotape shall be furnished to the Village in DVD format. Videotaping shall be performed by a reputable company meeting the approval of the Village, in the presence of a representative of the Village, and shall be performed prior to the commencement of construction. The videotape survey shall serve as a basis for establishing damage that has occurred as a result of construction operations.

**Basis of Payment:** This work will be paid for at the contract **LUMP SUM** price for:

#### **PRECONSTRUCTION VIDEOTAPING,**

which price shall be payment in full for the work as specified herein.

### **SP-6 CONSTRUCTION STAKING**

**Description:** Section 5-7 of the Water and Sewer Specs shall be replaced in its entirety by the following:

The Contractor shall furnish and place all construction layout stakes for this project. Competent personnel with suitable equipment shall conduct this work, supervised by a licensed Illinois Land Surveyor. The Contractor shall be responsible for having the finished work conform substantially to the lines, grades, elevations and dimensions shown on the plans.

The Contractor shall provide adequate control points to construct the individual Project elements, and shall provide the Engineer with adequate control in close proximity to check the compliance of the elements constructed.

**Basis of Payment:** This work will be paid for at the contract **LUMP SUM** price for:

#### **CONSTRUCTION STAKING,**

which price shall be payment in full for the work as specified herein.

### **SP-7 TRAFFIC CONTROL, MAINTENANCE OF TRAFFIC, DETOURS**

This item shall include the furnishing, installing, maintaining, relocating and removing of all traffic control devices and personnel used for the purpose of regulating, warning, or directing traffic during the construction of this project. Placement and maintenance of all traffic control devices shall be in accordance with the applicable parts of Article 107.14 and Section 701 of the Standard Specifications and included Highway Standards. All traffic control devices used on this project shall conform to the Standard Specifications for Traffic Control Devices and the Illinois Manual on Uniform Traffic Control Devices and as indicated on the Traffic Control

## Village of Downers Grove – S-008-23 ROW ACCESSIBILITY IMPROVEMENTS

Plan. No waiving of these requirements will be allowed without prior written approval of the Engineer.

The Contractor shall protect all workers engaged in the project, and shall provide for safe and convenient public travel by providing adequate traffic control under all circumstances. Such circumstances may include, but not be limited to work performed along the route under construction, road closures for construction operations of any type, or when any section of the road is opened to traffic prior to completion of all work. The Contractor shall ensure that work zone in question is properly signed, barricaded and otherwise marked.

The Contractor will be responsible for the proper location, installation, and arrangement of all traffic control devices during the period of construction. All open excavations shall be protected by Type I barricades equipped with working bi-directional flashing lights at each end of the excavation, as well as at 50-foot intervals between ends for excavations greater than 50 feet in length and weighted down by **one sandbag per each barricade**. All street closures shall be protected by Type III barricades equipped with working bi-directional flashing lights and weighted down by **eight sandbags per each barricade**.

The Contractor shall plan the work not to leave any open excavations during non-working hours and that all barricades not necessary have been removed from the pavement during non-working hours.

In the event that one direction of vehicular travel must be closed, the Contractor shall use certified flaggers (minimum of two) to direct traffic around the work area. The Engineer shall approve proper signing and barricading of the lane closures, and shall issue written authorization prior to closure. Presence of certified flaggers shall be required anytime the contractor's activities may impede the designated flow of traffic.

In the event that both directions of vehicular travel must be closed, the Contractor shall set up a detour route to direct traffic around the work area. The Engineer shall approve proper signing and barricading of the detour route and shall issue written authorization prior to closure. Where it is necessary to establish a temporary detour, all the requirements of the Standard Specifications and MUTCD shall be met.

The Contractor shall maintain his operations in a manner such that traffic flow shall not be substantially impeded during the construction of the proposed improvements. Where traffic must cross open trenches during a given work day, the Contractor shall provide steel plates at street intersections and driveways. Prior to the end of a given work day, the pavement surface shall be temporarily restored.

No open excavation may be left overnight or on the weekend without the express written permission of the Engineer.

As the condition and location of the work changes, the Contractor shall maintain all traffic control devices and personnel engaged in traffic control, in a manner that will accommodate the changing particulars of the work at any given time. Advance warnings, detour and directional information and other controls or directions necessary for safe passage of traffic around the work site shall be reviewed and changed, if necessary, to meet the needs of the situation. Signage erected, but not necessary or proper for the situation ahead shall be covered or taken down. Barricading and signage shall be monitored by the Contractor on a daily basis to ensure that it meets the requirements for work zone safety for the conditions of the particular work being performed.

In the event public sidewalks are closed to pedestrians, a minimum of two barricades (one on either side of the

## Village of Downers Grove – S-008-23 ROW ACCESSIBILITY IMPROVEMENTS

work zone) with operable flashing lights shall be used. Additionally, in the event public sidewalks are closed to pedestrians at intersections or mid-block crossings, the Contractor shall provide SIDEWALK CLOSED AHEAD signs at the nearest intersections to the closure and/or at the locations determined by the Engineer.

Access to all properties shall remain open at all times unless work is taking place in the immediate vicinity, requiring that access be restricted on a temporary basis. Full access must be restored immediately upon the completion of any work blocking said access, and full access must be restored to all properties over weekends and legal holidays unless approved by the Engineer. Special consideration to hours and location of work near school shall be made to allow for full and safe access during normal student arrival and departure schedules. The Contractor is responsible for all traffic control and this item is incidental to the cost of the overall contract work.

The Contractor shall provide a name and phone number of a responsible party capable of providing emergency service, 24 hours per day, for the duration of the Project.

### **DEFICIENCY CHARGE:**

The primary concern of the Village is to maintain a safe travel way for the public and a safe environment for the work in the construction zone. The Contractor is expected to comply with the Standard Specifications, contract plans, the Special Provisions and directions from the Engineer concerning traffic control and protection. The Contractor shall provide a telephone number where a responsible individual can be contacted on a 24-hour-a-day basis to receive notification of any deficiencies regarding traffic control and protection. The Contractor shall immediately respond correcting traffic control deficiencies by dispatching workers, materials and equipment to correct such deficiencies.

Failure to comply with the Contract or as directed by the Engineer as it relates to corrections or modifications to the traffic control and protection will result in a deduction of either \$1,000 or 0.05 percent of the awarded contract value, whichever is greater, in accordance with Article 105.03. This charge is separate from the cost of any corrective work ordered. The Contractor shall not be relieved of any contractual responsibilities by the Village's actions.

Basis of Payment: This work shall be paid for at the contract **Lump Sum** price for:

### **TRAFFIC CONTROL, MAINTENANCE OF TRAFFIC, DETOURS**

which price shall be payment in full for the installation and maintenance of any and all traffic control devices, including but limited to those specified herein, to protect the work and public for the duration of the Project.

### **SP-8 IEPA CLEAN CONSTRUCTION OR DEMOLITION DEBRIS**

**Construction Requirements:** The Contractor shall be responsible for satisfactory removal and disposal of all waste material, asphalt, concrete, stone, dirt, and debris generated or discovered in the course of the work. Removal and disposal of excavation items being disposed of at a clean construction and demolition debris (CCDD) facility shall meet the requirements of Public Act 96-1416. This work shall be incidental and shall not be paid for separately, with the exception of the **ADDITIONAL HAULING SURCHARGE, NON-HAZARDOUS SPECIAL WASTE** as specified below.

## Village of Downers Grove – S-008-23 ROW ACCESSIBILITY IMPROVEMENTS

The temporary storing of excavated materials within the public right-of-way or project limits shall not be allowed unless approved by the Engineer. It shall be the Contractor's responsibility to find an approved dumpsite for debris and any excavated materials. The Village will not provide one.

The Contractor shall employ a licensed testing firm, as approved by Engineer, to screen each truck-load of material on-site, using a PID or FID field screen or other acceptable method. The PID shall be calibrated on a daily basis. The Contractor shall enter all truck-loads leaving the site into an on-site screening log including, but not limited to, project name, date, time, weather conditions, name of screener, hauling company, truck number, screening method, background PID reading, calibrated PID reading, truck/bucket PID reading, and description of materials screened. Each day prior to the first truck leaving the site, Engineer and Contractor's testing consultant shall agree on the allowable PID reading in accordance with the receiving CCDD facility procedures (typically 0.0 or daily background levels). The receiving CCDD facility may be consulted daily, or periodically, as needed to verify that the appropriate value is being used. If said screen indicates levels that will be unacceptable for disposal at the CCDD facility, the material shall be quarantined on-site for further evaluation. If material is rejected at the CCDD facility, it shall be returned to the project site and quarantined for further evaluation. No additional compensation shall be allowed for returning a rejected load back to the project site, or any other additional hauling, loading, unloading, etc, as may be required. Should it be determined by the Village or Village's agent that the material is not suitable for disposal in a CCDD facility, the Contractor shall be responsible for properly disposing of the material at an acceptable landfill, and providing the Village with all of the proper paperwork to document the material disposal with the IEPA. This work shall be paid for as specified below. If a truck-load is rejected by a CCDD facility after leaving the project site, and said truck-load is not identified in the on-site screening log, the Contractor shall still be required to properly dispose of the material and provide the Village with the necessary documentation, but shall not be additionally compensated as specified below.

All additional work to satisfy these requirements shall be the responsibility of the Contractor. All costs associated with meeting these requirements shall be paid for as specified herein. These costs shall include but are not limited to all required testing, lab analysis, and certification by a licensed professional engineer (PE) or licensed professional geologist (PG), if required, in addition to the cost of additional hauling, dump fees, etc. Payment for this work shall be in addition to payment for EXCAVATION, SPECIAL per the contract unit price. No adjustment to the contract unit price will be allowed due to changes to quantities based on actual field conditions.

**Basis of Payment:** This work shall be paid for at the contract unit price per **LOAD** for:

**ADDITIONAL HAULING SURCHARGE, NON-HAZARDOUS SPECIAL WASTE,**

which price shall be payment in full for the work as specified herein.

**SP-9 DRIVEWAY ACCESS NOTIFICATION**

**Description:** If access to a driveway will be blocked, the Contractor shall give that resident or business proper written notification at least 24 hours in advance. The Contractor must provide them the opportunity to remove their cars from the driveway or make other arrangements. In addition, the Contractor shall be responsible for notifying the resident or business verbally on the morning of any driveway closure, to ensure awareness of the lack of access.

Village of Downers Grove – S-008-23 ROW ACCESSIBILITY IMPROVEMENTS

Samples of written notices shall be submitted to the Engineer for approval before Notice to Proceed is given.

**Basis of Payment:** This work shall be considered **INCIDENTAL** to the project.

**SP-10 TREE PROTECTION**

**Description:** Municipal Codes regarding trees, including tree protection requirements for public parkway trees, are located in Chapter 24 of the Downers Grove Municipal Code. Specifically, Municipal Codes 24-7 and 24-8 detail the public parkway tree protection sizes and fines for violations. The Village Forester shall approve all tree protection measures and any deviations. All tree protection measures and any deviations shall be noted in the contract specifications and on approved project plan sheets and permits using the guidelines listed below.

Tree protection shall include avoiding damage to the above ground tree branches and trunk, and the below ground root system and surrounding soil. Tree crowns and trunks shall not suffer any branch or bark loss. Roots shall be protected from compaction, storage of materials, severing, regrading of the parkway or excavation unless specifically noted on the project plan sheets.

The Critical Root Zone, or CRZ, is the area immediately surrounding a tree that must be protected from damage. In a municipal parkway setting with utilities and paved or concrete surfaces, the size of the CRZ has been adjusted to form a rectangle around the parkway tree trunk with minimum dimensions listed in the following table. The depth of the CRZ extends to 4 feet below the natural ground surface level.

<u>Parkway</u> <u>Tree diameter at 4.5'</u>	<u>Width street to property</u> <u>(min. curb to sidewalk)</u>	<u>Length along street</u> <u>street(minimum)</u>	<u>Depth</u>
0 – 12.0 inches	10.0 feet	10 feet	4 feet
12.1 – 24.0 inches	10.0 feet	20 feet	4 feet
24.1 or more inches	10.0 feet	30 feet	4 feet

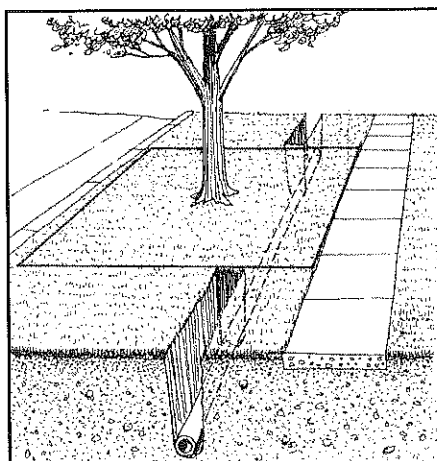

For projects that involve excavations of less than one (1) foot in depth in the parkway or street and are replacing structures in the same location, fencing of the public parkway trees shall not be required. Example projects include, but are not limited to, street pavement resurfacing, curb removal/replacement, driveway removal/replacement, or sidewalk removal/repairs or new sidewalk installations. Contractors shall be mindful

## Village of Downers Grove – S-008-23 ROW ACCESSIBILITY IMPROVEMENTS

of the CRZ dimensions and potential for fines if any parkway trees suffer any unauthorized damage as determined by the Village Forester.

For projects that involve excavations of one (1) foot or more in depth in the parkway or street or both, fencing of the public parkway trees shall be required. Example projects include, but are not limited to, watermain replacements with new roundway keystops and domestic service box installations, sanitary line replacements and new service connections, new or replacement natural gas services, new or replacement phone or fiber optic lines, or new or replacement storm sewers, or projects that widen roads which in turn decreases the parkway soil volume around public parkway trees.

Projects that require fencing (listed above) shall fence the public parkway trees with six (6) foot high chain link construction fence secured to metal posts driven in the ground which are spaced no further than ten (10) feet apart. The dimensions of the fence shall depend on the tree diameter size and shall follow the table listed for the CRZ above, or as large as practical dependent on driveways and other field conditions. The fenced rectangle shall have three (3) sides with the opening facing the adjacent residences for easy access for mowing or tree care. Under no circumstances shall any items be stored within the fence. All fencing shall be maintained daily in an upright good condition. The size and location of all fencing shall be shown on the project plan sheets.

To avoid damage to the CRZ, utilities must be augered underneath the public parkway trees. Excavation pits for augering equipment are to be outside the fenced area and are to be shown on the project plan sheets. Excavation pits for roundway keystops and domestic service boxes are to be as small as practical with excavation occurring in a direction away from the adjacent public parkway tree.

In cases when severing of roots within a portion of the CRZ may be unavoidable (ex. sidewalk installation, curb replacement, water or sanitary service replacement), subject to the approval of the Village Forester, sharp clean cuts shall be made on root ends to promote wound closure and root regeneration. Root pruning and excavation activities shall occur such that the smallest volume of soil and roots is disturbed, and the locations shall be shown on the project plan sheets.

In addition to fines and citations that may be assessed for violations of any Chapter 24 of the Municipal Code (such as not maintaining fencing around the CRZ or unauthorized removal of protected trees), the contractor may be subject to the following provisions:

- Issuance of an invoice for the value or partial value of the tree lost due to damage to either the above ground or below ground portions of the parkway tree, or unauthorized tree removal.
- Costs of repairs, such as pruning or cabling, or costs for removal of the damaged parkway tree along with the stump if the tree cannot remain in the right-of-way.
- Fines of \$500 for the 1<sup>st</sup> offense; \$1,000 for the 2<sup>nd</sup> offense; \$2,500 for the 3<sup>rd</sup> and subsequent offenses.
- Each day during which a violation continues shall be construed as a separate and distinct offense.

The value or partial value of the tree lost shall be determined by the Village Forester using the most current edition of the Guide for Plant Appraisal (prepared by the Council of Tree & Landscape Appraisers and the International Society of Arboriculture) and the most current edition of the Species Ratings & Appraisal Factors for Illinois (prepared by the Illinois Arborist Association). The total cost determined for the damage

## Village of Downers Grove – S-008-23 ROW ACCESSIBILITY IMPROVEMENTS

311 and of Article 1004.04 of the SSRBC for the purpose of leveling-off the sub-base to place uniform thickness of sidewalk; use of recycled materials shall not be allowed unless with a prior written permission by the Engineer;

- d. The set up of form work such that the maximum running slope of the finished walk does not exceed 5 percent (1:20) or not to exceed the general grade established for the roadway, and the cross slope is not more than 2 percent (1:50) where feasible and as directed by the Engineer;
- e. The placement of five inch (5") thick, Class SI Portland Cement Concrete, 5.65 cwt/cy mix, with 5-8% air entrainment, 2"-4" slump, and six inch (6") thickness through or in residential driveways or where subject to vehicular traffic, to the width specified on the plans or as directed by the Engineer;
- f. The tooling of contraction joints, 1/2-inch radius and 1 inch deep, 5 feet on center;
- g. The placement of 1/2 inch thick premoulded expansion joints at 50 foot intervals on center, or abutting existing concrete sidewalk, or at the end of a pour or as directed by the Engineer;
- h. The installation per Village Standards of all traffic control devices removed by the Contractor;
- i. The proper curing of all concrete work utilizing methods and materials outlined in Articles 424 and 1022.01 of the SSRBC, (Type III membrane curing compound white pigmented), **WORK THAT IS NOT PROPERLY CURED WILL NOT BE ACCEPTED OR PAID FOR;**
- j. Installation of ADA compliant ramps for curbed and non-curbed streets.

**NOTE: Placement of concrete shall not be allowed prior to the Engineer inspecting the base material. PCC sidewalk installed without prior inspection and approval of the base material will not be accepted for payment. The Contractor shall at the direction of the Engineer remove and replace the section (s) of sidewalk in question at no cost to the Village.**

**Basis for Payment:** This work shall be paid for at the contract unit price per **SQUARE FOOT** for:

**P.C.C. SIDEWALK, 5 INCH**

which price shall be payment in full for the work as specified herein.

**SP-13 DETECTABLE WARNINGS**

**Description:** This work shall consist of the installation of new detectable warning material as shown in the plans. All detectable warnings shall be placed by methods and with materials in accordance with Article 424 and 424.09 of the SSRBC.

Detectable Warnings shall be brick red, cast-in-place composite panels with inline dome pattern. Panels shall be installed full width of the walk (2" max concrete border allowed) in accordance with the latest PROWAG guidelines and at the direction of the Public Works Director (or his/her designee).

Detectable Warnings shall be:

- 1) Access-Tile Cast-In-Place Replaceable,
- 2) Tuff Tile Wet-Set Replaceable Tile

or equivalent equal.

**Basis for Payment:** This work shall be paid for at the contract unit price per **SQUARE FOOT** for:

## Village of Downers Grove – S-008-23 ROW ACCESSIBILITY IMPROVEMENTS

**DETECTABLE WARNINGS,**

which price shall include all material, labor, and equipment necessary to complete this item.

**SP-14 CONCRETE CURB TYPE B, 6”**

This work shall consist of the placement of Concrete Curb, of the type, size and location shown on the plans. All Concrete Curb shall be placed by methods and materials as specified in Articles 606 and 1020 of the SSRBC, except as amended herein.

The curb shall be placed on a bed of six inches compacted CA-6 Aggregate. Backfill shall consist of CA-6 aggregate and shall be incidental to Concrete Curb installation. Backfill shall be tamped in place with a mechanical tamper.

The topsoil and sod restoration shall be in accordance with provision for SOD RESTORATION and shall be considered incidental within costs associated for the retaining wall installation.

Placement of Concrete Curb Type B shall include the following:

- a) The use of Class SI Portland cement concrete, 6.05 cwt/cy mix, with 6% air entrainment, 3" slump;
- b) The saw cutting of 2 inch deep joints at not more than 15-foot intervals, within 24 hours after being placed;
- c) The placement of 2 dowel bars spaced at 6” on center equal distance from top and bottom of the curb of existing concrete curb, and at expansion joints, in accordance with the detail shown on the plans;
- d) The placement of 3/4 inch pre-molded expansion joint filler perpendicular to the centerline of the roadway for the full depth of the curb, where abutting existing concrete curb and gutter, at 10 feet either side of a utility structure, at construction joints at the ends of pours, at not more than 90 foot intervals;
- e) The proper curing of all concrete work utilizing the methods and materials outlined in Articles 424 and 1022.01 of the SSRBC (Type 2 membrane curing with red dye is preferred);
- f) The backfilling of all curb work with materials approved by the Engineer.

At locations shown on the plans or where directed by the Engineer the contractor will use High-early strength concrete. The desired concrete mix shall have a minimum compressive strength of 3,000 psi at 24 hours. Mix design shall be submitted to the Engineer for review and approval.

**Basis for Payment:** This work shall be paid for at the contract unit price per **FOOT** for:

**CONCRETE CURB TYPE B, 6”,**

which price shall be payment in full for the work as specified herein.

**SP-15 UTILITY STRUCTURES TO BE ADJUSTED**

Although the cost of adjusting and/or reconstructing structures per this specification will be paid for under this contract, the contractor shall be aware that many of the structures are not the property of the Village of

## Village of Downers Grove – S-008-23 ROW ACCESSIBILITY IMPROVEMENTS

Downers Grove, and that such work may require inspections and/or permits from other governmental agencies.

### A. DRAINAGE AND UTILITY STRUCTURES

This work shall consist of the removal and disposal of the existing frame and lid/grate; installation of the applicable new frame and lid/grate; all labor, equipment and material required to adjust or reconstruct manholes, catch basins, inlets, handholes and valve vaults in accordance with Section 602 of the SSRBC. This item will include all excavation, concrete and trench backfill.

### B. SANITARY MANHOLES

This method shall be used for all manholes which will have less than seven and one-half (7 ½”) inches of adjustment between the top of the cone and the bottom of the frame when set at finished grade. To raise the frame, adjustment shall be made using precast reinforced concrete rings. Concrete blocks or bricks shall not be used. The spaces between the cone, rings and frame shall be completely sealed with preformed bituminous mastic (Easy Stik or approved equal). Mortar shall not be used. To lower the frame, existing adjustments shall be removed and the space between the frame and the cone shall be removed and the space between the frame and the cone shall be completely sealed with preformed bituminous mastic gasket. If the manhole would have seven and one-half (7 ½”) inches or more of adjustments when set at the finished grade or if the frame must be lowered by more than the amount of existing adjustment, the manhole shall be reconstructed. Refer to Downers Grove Sanitary District specifications for manhole reconstruction. The Downers Grove Sanitary District shall be notified of manholes to be adjusted prior to beginning construction. Once completed, no such adjustment shall be backfilled without inspection by the Downers Grove Sanitary District.

This work shall be paid for at the contract unit price per **EACH** for **DRAINAGE & UTILITY STRUCTURE TO BE ADJUSTED**.

### SP-16 TREE ROOT PRUNING

**Description:** All trees, public or private, affected by new sidewalk installation within its root protection zone, shall be root pruned prior to any excavation taking place. Root pruning shall be performed in accordance with the Tree Protection Zone detail of the Plans, and shall be done only to the depth of the excavation necessary for installing the new sidewalk. Root pruning shall start and proceed uninterrupted for the length of travel through the root protection zone. Root pruning shall be made no more than ten inches (10”) from the tree-side edge of the proposed sidewalk.

Approval by the Village Forester of the equipment to be used for root pruning, as well as the proposed path of the root pruning work, is required prior to the work being performed. The Engineer or his representative shall permit no excavation until written approval is obtained by the Contractor from the Village Forester. No materials or equipment may be stored or kept in the Tree Protection Zone. Tree damage, as determined by the Village Forester, shall be assessed to the Contractor using the most recent edition of the Guide for Plant Appraisal, published by the International Society of Arboriculture.

**Basis of Payment:** This work shall be paid for at the contract unit price per **FOOT** for:

**TREE ROOT PRUNING,**

## Village of Downers Grove – S-008-23 ROW ACCESSIBILITY IMPROVEMENTS

which price shall be payment in full for the work as specified herein and as measured in place.

**SP-17 AGGREGATE FOR TEMPORARY ACCESS**

**Description:** This work shall consist of the construction and maintenance of an aggregate surface course for maintaining access to intersecting streets and driveways as specified in Article 107.09 of the Standard Specifications. During construction, the Contractor shall provide access at all times for emergency vehicles, school buses, and all abutting properties.

Aggregate for temporary access roads and driveway aprons shall be removed and/or reused at the direction of the Engineer. Aggregate surface shall be constructed in accordance with the applicable portions of Section 402 of the Standard Specifications excepting that the coarse aggregate shall meet CA-6 gradation, and that the equipment required for the work will be as directed by the Engineer. Maintenance shall consist of placing and compacting additional aggregate of the same type and gradation as the surface aggregate.

**Basis of Payment:** This work will be paid for at the contract unit price per TON for AGGREGATE FOR TEMPORARY ACCESS, which price shall include furnishing, transporting, placing, maintaining, and removing, reusing or disposing of the aggregate as herein specified and as directed by the Engineer. Payment for aggregate will be made for its initial use only, regardless of the number of times it may be moved.

**SP-18 EARTH EXCAVATION, SPECIAL**

**Description:** This work shall consist of the excavation, removal, and disposal of existing materials located on site required for installation of sidewalk ramps. Earth Excavation shall include removal of existing aggregate base and underlying soil to the depth specified on the plans. Removal of existing concrete shall be paid for under SIDEWALK REMOVAL. This work shall be as specified and in accordance with Sections 202, 204, 205 and 440 of the SSRBC and as specified herein.

**Method of Measurement:** This work will not be measured for payment. Payment will be based on Contract Quantities. By submission of a bid, Contractor agrees to Contract Quantity.

**Basis of Payment:** This work shall be measured and paid for at the contract unit price per CUBIC YARD for:

**EARTH EXCAVATION, SPECIAL**

which shall include all labor, materials and equipment necessary to do the work.

**SP-19 WEED CONTROL, PRE-EMERGENT**

**Description:** This work shall consist of spreading a pre-emergent granular herbicide in areas as shown on the plans or as directed by the Engineer. This item will be used in mulched plant beds and mulch rings.

**Materials:** The pre-emergent granular herbicide (Snapshot 2.5 TG or equivalent) shall contain the chemicals Trifluralin 2% active ingredient and Isoxaben with 0.5% active ingredient. The herbicide label shall be submitted to the Engineer for approval at least seventy-two (72) hours prior to application.

**Method:** The pre-emergent granular herbicide shall be used in accordance with the manufacturer's directions on the package. The granules are to be applied prior to mulching.

## Village of Downers Grove – S-008-23 ROW ACCESSIBILITY IMPROVEMENTS

Apply the granular herbicide using a drop or rotary-type designed to apply granular herbicide or insecticides. Calibrate application equipment to use according to manufacturer's directions. Check frequently to be sure equipment is working properly and distributing granules uniformly. Do not use spreaders that apply material in narrow concentrated bands. Avoid skips or overlaps as poor weed control or crop injury may occur. More uniform application may be achieved by spreading half of the required amount of product over the area and then applying the remaining half in swaths at right angles to the first. Apply the granular herbicide at the rate of 100 lbs/acre (112 kg/ha) or 2.3 lbs/1000 sq. ft. (11.2 kg/1000 sq. meters).

**Method of Measurement:** Pre-emergent granular herbicide will be measured in place in Pounds of Pre-emergent Granular Herbicide applied. Areas treated after mulch placement shall not be measured for payment.

**Basis of Payment:** This work will be paid for at the contract unit price per **POUND** of

### **WEED CONTROL, PRE-EMERGENT**

which price shall include all materials, equipment, and labor necessary to complete the work as specified.

#### **SP-20 SAW CUTTING**

**Description:** This work shall consist of saw cutting existing sidewalk along the limits of removal as indicated by the Engineer. Saw cutting shall be full depth for bituminous pavement and 1-1/2 inch depth for concrete through drive approaches for removal of driveway necessary for sidewalk installation for the purpose of delineating sidewalk edges and contraction joints where none currently exist.

**Basis of Payment:** Saw cutting shall not be paid for separately but shall be **INCIDENTAL** to the contract.

#### **SP-21 SIGN RELOCATE**

**Description:** The Contractor shall remove and relocate all signs located in or near the construction zone as directed by the Engineer. The Contractor shall be responsible for replacing, at his expense, any signs damaged during the course of construction and the operation of removing and relocating any signs.

**Basis of Payment:** The removal and relocation of all existing signs in or near the construction zone shall not be paid for separately but shall be **INCIDENTAL** to the contract.

#### **SP-22 PROTECTION OF WORK**

The Contractor shall be responsible to provide personnel to protect his work from third party damage. Should any of the work be damaged, it shall be removed and replaced at the Contractor's expense. The Contractor shall schedule his work so that the concrete placed takes its initial set during daylight hours. Claims of darkness shall not be reason to relieve the Contractor from responsibility. Driveways shall be kept barricaded for a minimum of four (4) days after placement of concrete or as determined by the Engineer. The curing time may be reduced if High Early Strength PCC is used.

#### **SP-23 SOD RESTORATION**

**Description:** This item shall be done in accordance with the applicable portions of Sec. 252 of the Standard Specifications and the following provisions.

## Village of Downers Grove – S-008-23 ROW ACCESSIBILITY IMPROVEMENTS

With the exception of turf areas as determined by the Engineer to be re-graded, ~~which are typically associated with the pay item SIDEWALK REMOVAL AND REPLACEMENT (DRAINAGE ISSUE), 5<sup>22</sup>-6<sup>22</sup>,~~ restoration of all turf directly adjacent to sidewalk removal and installation will not be considered for payment and shall be considered incidental to placement of said items as stated herein. Restoration of disturbed turf 6" or less in width can be restored with topsoil and seed. Restoration of disturbed turf greater than 6" in width shall be restored with sod per the requirements specified herein.

As contract work progresses through the Village, parkway restoration work shall commence in a timely manner in areas where permanent placement of new curb and gutter, driveways, sidewalks, etc., has been completed. Under no circumstances shall the Contractor prolong final grading, shaping and sod placement so that the entire project can be permanently restored at the same time.

This work shall consist of the excavation, topsoiling and sodding from a minimum of one and one-half (1-1/2) feet to a maximum of three (3) feet behind or adjacent to all curbs, sidewalks and driveways removed and replaced during the course of construction or as directed by the Engineer. Restoration will also be performed on areas disturbed by storm sewer or culvert construction.

All topsoil to be used for parkway restoration shall be obtained from outside the limits of this improvement, transported to the site and placed at required locations to a minimum depth of 6". All materials shall meet the requirements of Art. 1081.05 of the Standard Specifications. All placement of topsoil shall meet the requirements of Sec. 211 of the Standard Specifications.

All sod shall be an approved grass that is native to the locality of work meeting the requirements of Art. 1081.03 of the Standard Specifications. All placement of sod shall meet the requirements of Sec. 252 of the Standard Specifications.

**The Contractor shall properly backfill, compact and grade all disturbed areas adjacent to newly constructed curb and gutter, sidewalks and driveways within 5 calendar days of their completion.** Backfill shall be compacted by mechanical and/or hand methods so future consolidation / settlement does not occur. Disturbed areas shall be left in a safe, clean and usable condition conducive to foot traffic and to the satisfaction of the Engineer.

**Disturbed turf areas shall be permanently restored with topsoil and sod or, if sod placement falls outside specifications for sod placement, temporarily stabilized with GROWTH-INHIBITING EROSION CONTROL BLANKET within 14 calendar days of final disturbance of the turf area.** If timing of restoration work falls outside of specifications for sod placement, topsoil and growth-inhibiting erosion control blanket shall be installed within the required restoration timeframe and sod shall be installed when specifications allow. The material specifications shall be submitted to the Village for approval prior to use. The blanket shall consist of a material which inhibits the growth of weeds, such that the area does not require additional tilling of topsoil prior to sod placement. The installation of the blanket shall follow manufacturer's specifications such that no soil or debris shall run off from the disturbed areas. Following the use of any blanket, the Contractor shall remove the product from the site.

**Basis of Payment:** This work will be paid for at the contract unit price per **SQUARE YARD** for:

## Village of Downers Grove – S-008-23 ROW ACCESSIBILITY IMPROVEMENTS

**SOD RESTORATION**

and/or

**GROWTH-INHIBITING EROSION CONTROL BLANKET,**

which price shall be payment in full for any excavation and grading necessary, the furnishing, transporting and placement of all topsoil and sod, and the full watering of sod. Unless otherwise directed by the Engineer, restoration of disturbed parkways more than three (3) feet behind the back of curb or more than three (3) feet adjacent to newly constructed driveway or sidewalk or more than six (6) feet either side of the newly placed storm sewer or pipe culvert, will not be paid for separately but shall be considered incidental to the contract. The installation of temporary growth-inhibiting erosion control blanket shall be paid for at the contract unit price per Square Yard for GROWTH-INHIBITING EROSION CONTROL BLANKET.

Supplemental watering shall be paid for at the contract unit price per unit for SUPPLEMENTAL WATERING.

**SP-24 EROSION AND SEDIMENTATION CONTROL**

**Description:** Throughout each and every phase of the project, all downstream ditches and storm sewers shall be protected from the run-off of roadway surfaces, excavations, and other construction activities generating the movement of dirt, mud, dust and debris. This work shall consist of constructing temporary erosion and sedimentation control systems as shown on the plans or as directed by the Engineer. The work shall be placed by methods and with materials in accordance with Sections 280, 1080 and 1081 of the SSRBC, except as amended herein.

All downstream ditches shall be protected from erosion and sedimentation by the installation of an Engineer-approved compost filter sock. Piles of excavated material and/or trench backfill material, allowed to be in place in excess of three days, shall be protected against erosion and sedimentation runoff by use of a compost filter sock. Storm sewer inlet structures or manholes shall be protected by temporary placement of filter baskets or compost filter socks as authorized in the field by the Engineer. Dewatering and bypass pumping and all sediment control measures required, in addition to measures shown on plans, shall be incidental to the installation of storm sewer pipes and structures.

Erosion and sedimentation control measures as indicated in the Erosion Control Plan, or as directed by the Engineer shall be installed on the project site prior to beginning any construction activities which will potentially create conditions subject to erosion. Erosion control devices shall be in place and approved by the Engineer as to proper placement and installation prior to beginning other work. Erosion control protection for Contractor equipment storage sites, plant sites, and other sites shall be installed by the Contractor and approved by the Engineer prior to beginning construction activities at each site. Failure to properly install and maintain erosion control measures per the Erosion Control Plan, or as directed by the Engineer, shall result in a \$1000/day fine, which shall be deducted from the value of work completed, until deficiencies are rectified as approved by the Engineer.

**Perimeter Erosion Barrier and Inlet Filters:** Items include placement, maintenance, and removal of compost filter socks and filter baskets at areas designated by the Engineer.

Village of Downers Grove – S-008-23 ROW ACCESSIBILITY IMPROVEMENTS

**Basis of Payment:** This work will be paid for at the contract **FOOT and EACH** price, respectively, for:

**PERIMETER EROSION BARRIER**

**and**

**INLET FILTERS,**

which price shall be payment in full for the work as specified herein.

**SP-25 MODULAR CONCRETE BLOCK RETAINING WALL**

**Description:** This work shall consist of the furnishing of materials and installation of a MODULAR CONCRETE BLOCK RETAINING WALL. This wall shall be constructed with high strength density concrete modular units, freeze thaw resistant with rear alignment flange providing a one and one-eighth inch (1 1/8") set back from a vertical plane with each course. Modular units shall be Unilock – Pisa 2 Natural or approved equal. Concrete Modular Retaining Wall units shall meet or exceed the standards outlined in ASTM C90-90 (Specification for Load Bearing Concrete Masonry Units): and ASTM C666-90 (Test Method for Resistance of Concrete to Rapid Freezing and Thawing).

Erection of the wall shall be in accordance with the concrete module manufacturer's recommendations and as specified herein. The wall shall be placed on a bed of six inches compacted CA-6 Aggregate. The top of the first row of concrete modules shall be set at one inch below the lowest top of walk for that course of modules. Each course shall be laid with the lip of the units placed against the back of the preceding course. Units shall be pulled forward as far as possible. The first layer shall have a one-inch tieback bank.

For drainage within the retaining wall, a perforated 4-inch dia. PVC tile shall be wrapped within a porous geofabric textile and placed along the retaining wall's entire length.

Excavation shall be conducted as to obtain a 45-degree angle as measured from the heel of the retaining wall to the furthest point of excavation on the surface of the hill to be retained.

Backfill shall consist of CA-6 aggregate and shall be incidental to retaining wall installation. Backfill shall be tamped in place in eight-inch lifts with a mechanical tamper, prior to installing the succeeding layer of modules.

Wall units damaged during erection of the wall shall be replaced by the Contractor with new units. Excess excavated material resulting from the construction of the wall shall be removed from within the limits of the Village of Downers Grove.

Four (4) inches of topsoil shall be placed on a clay cap six (6) inches thick. The topsoil and sod restoration shall be in accordance with provision for PARKWAY RESTORATION (SPECIAL).

**Basis of Payment:** This Work shall be paid for at the contract unit price per **SQUARE FOOT** for:

**MODULAR CONCRETE BLOCK RETAINING WALL.**

## Village of Downers Grove – S-008-23 ROW ACCESSIBILITY IMPROVEMENTS

**SP-26 EXPLORATORY TRENCH, SPECIAL**

**Description.** This item shall consist of excavating an area for the purpose of locating existing utilities within the construction limits of the proposed improvements. The Contractor shall perform exploratory trenching for all existing utilities potentially in conflict with the proposed improvements. The Contractor shall proactively perform exploratory trenching in a timely fashion to help mitigate delays, if any, caused by conflicts with existing utilities. The Contractor shall also perform exploratory trenching as directed by the Engineer. It shall be the responsibility of the Contractor to immediately inform the Engineer of any conflicts with existing utilities in conflict with the proposed improvements. A nominal quantity of exploratory excavation has been included in the schedule of prices for the purpose of establishing a unit price for this item of work.

After the excavation has been inspected, it shall be backfilled as directed by the Engineer. If it is located within 2' of a paved area (existing or proposed), the excavation shall be backfilled with Trench Backfill as specified herein. Otherwise, the excavation shall be backfilled with excavated material compacted to the satisfaction of the Engineer. Any excess material shall be disposed of in accordance with Article 202.03 of the IDOT Standard Specifications.

Exploratory trenching will be measured in its original position and the volume calculated in cubic yards based upon the dimensions of the excavation. Trench Backfill will not be measured for payment and shall be included in the unit price of EXPLORATORY TRENCH, SPECIAL.

**Basis of Payment:** This work will be paid for at the contract unit price per **CUBIC YARD** for,

**EXPLORATORY TRENCH, SPECIAL,**

measured as specified, which price shall include excavation, backfill and legal disposal of excess material.

**SP-27 HOT-MIX ASPHALT DRIVEWAY REMOVAL & REPLACEMENT, 3"**

**Description:** This work shall consist of the removal and replacement of asphalt driveways at locations indicated on the plan and/or as required by the Engineer.

The replacement of the driveways shall consist of preparing a subgrade at all required locations, shaping of slopes adjacent to the driveways, the placement and compacting of six inches of CA-6 Aggregate Base, and the placement and compacting of three inches (3") of Hot-Mix Asphalt Surface, Mixture D, N50 (IL 9.5).

This work shall also include the adjustment to proper grade of all water valve or private utility boxes encountered.

Engineer will mark limits of pavement removal and replacement. Pavement removal shall not take place prior to limits being provided by the Engineer.

**Basis of Payment:** This work shall be paid for at the contract unit price per **SQUARE YARD** for:

**HOT-MIX ASPHALT DRIVEWAY REMOVAL AND REPLACEMENT, 3",**

which price shall be payment in full for the work as specified herein.

## Village of Downers Grove – S-008-23 ROW ACCESSIBILITY IMPROVEMENTS

**SP-28 PCC DRIVEWAY REMOVAL & REPLACEMENT, 6”**

**Description:** This work shall consist of the removal and replacement of concrete driveways in accordance with the applicable parts of Sec. 423 of the SSRBC except as amended herein.

This work shall include the placement of ¾” premolded expansion joints where new concrete abuts existing concrete or as directed by the Engineer.

This work shall also include the adjustment to proper grade of all water valve or private utility boxes encountered.

Engineer will mark limits of pavement removal and replacement. Pavement removal shall not take place prior to limits being provided by the Engineer.

Replacement of the driveways shall include the application of membrane curing compound, Type III, in accordance with Articles 1020.13 and 1022.01 of the SSRBC, unless otherwise directed by the Engineer. If replacement of the driveways takes place prior to April 15, or after October 15, the driveway shall be properly cured and that followed by the application of protective coat in accordance with Article 420.18 of the Standard Specifications.

**Basis of Payment:** This work shall be paid for at the contract unit price per **SQUARE YARD** for:

**PCC DRIVEWAY REMOVAL AND REPLACEMENT, 6”,**

which price shall be payment in full for the work as specified herein.

**SP-29 CLEANING UP**

The Contractor shall, at all times, keep the premises free from an accumulation of waste material or rubbish caused by his employees or work. At the end of the day, he shall remove all his rubbish from and about the streets and sidewalks. All his tools, form boards, and surplus materials shall be removed and relocated to any temporary on-site storage location assigned by the Village or its Engineer, and shall leave his work "broom clean" or its equivalent, unless more precisely defined. Upon completion of the work called for by the contract, and upon final inspection and acceptance, the Contractor shall remove any of his remaining rubbish, tools, form boards, and surplus materials completely from the work site.

In case of dispute, the Village may remove the rubbish and any other materials and charge the cost to the Contractor.

**SP-30 STORAGE OF MATERIALS AND EQUIPMENT**



At no time shall the Contractor store materials and equipment in private or public right-of-ways. Parking or storing construction vehicles and equipment overnight is strictly prohibited including, but not limited to, box trucks, dump trucks, pavers, trailers, etc.

Village of Downers Grove – S-008-23 ROW ACCESSIBILITY IMPROVEMENTS

**V. BID and CONTRACT FORM (Village)**

**\*\*\*THIS BID WHEN ACCEPTED AND SIGNED BY AN AUTHORIZED SIGNATORY OF THE VILLAGE OF DOWNERS GROVE SHALL BECOME A CONTRACT BINDING UPON BOTH PARTIES.**

**Entire Form Must Be Completed If a Submitted Bid Is To Be Considered For Award**

<b>BIDDER:</b>	
Alliance Contractors, Inc. Company Name	2/22/2023 Date
1166 Lake Ave. Street Address of Company	estimating@alliancecontractors.com E-mail Address
Woodstock, IL 60098 City, State, Zip	Scott A. Marquart Contact Name (Print)
(815) 338-5900 Business Phone	(815) 338-5900 24-Hour Telephone
(815) 338-9109 Business Fax	 Signature of Officer, Partner or Sole Proprietor
ATTEST: if a Corporation  Signature of Assistant Secretary	Scott A. Marquart, Vice President Print Name & Title
We hereby agree to furnish the Village of Downers Grove all necessary materials, equipment, labor, etc. to complete the project within the timeframe specified herein and in accordance with the provisions, instructions and specifications for the unit prices shown on the Schedule of Prices.	

**VILLAGE OF DOWNERS GROVE:**

**ATTEST:**

\_\_\_\_\_  
Authorized Signature

\_\_\_\_\_  
Village Clerk

\_\_\_\_\_  
Title

\_\_\_\_\_  
Date

\_\_\_\_\_  
Date

In compliance with the specifications, the above-signed offers and agrees, if this Bid is accepted within 90 calendar days from the date of opening, to furnish any or all of the services upon which prices are quoted, at the price set opposite each item, delivered at the designated point within the time specified above.

**BID 1 - PRAIRIE AND PERSHING NW**

ITEM NO.	ITEMS	UNIT	QNTY	UNIT PRICE	TOTAL PRICE
20101700	SUPPLEMENTAL WATERING	UNIT	1.0	250.00	250.00
67100100	MOBILIZATION	LSUM	1.0	2,060.00	2,060.00
44000600	SIDEWALK REMOVAL	SQ FT	375.0	2.00	750.00
SP-5	PRECONSTRUCTION VIDEOTAPING	LSUM	1.0	1.00	1.00
SP-6	CONSTRUCTION STAKING	L SUM	1.0	1.00	1.00
SP-7	TRAFFIC CONTROL, MAINTENANCE OF TRAFFIC, DETOURS	L SUM	1.0	1,000.00	1,000.00
SP-8	ADDITIONAL HAULING SURCHARGE, NON-HAZARDOUS SPECIAL WASTE	LOAD	1.0	250.00	250.00
SP-11	STREET SWEEPING AND DUST CONTROL	HOUR	2.0	50.00	100.00
SP-12	PORTLAND CEMENT CONCRETE SIDEWALK, 5 INCH	SQ FT	375.0	38.00	14,250.00
SP-13	DETECTABLE WARNINGS	SQ FT	20.0	40.00	800.00
SP-14	CONCRETE CURB, TYPE B-6"	FOOT	55.0	105.00	5,775.00
SP-16	TREE ROOT PRUNING	FOOT	25.0	30.00	750.00
SP-17	AGGREGATE FOR TEMPORARY ACCESS	TON	2.0	20.00	40.00
SP-18	EARTH EXCAVATION, SPECIAL	CUYD	11.0	10.00	110.00
SP-19	WEED CONTROL, PRE-EMERGENT	LBS	1.0	50.00	50.00
SP-23	GROWTH-INHIBITING EROSION CONTROL BLANKET	SQYD	35.0	1.00	35.00
SP-23	SOD RESTORATION	SQYD	35.0	30.00	1,050.00
SP-24	INLET FILTERS	EACH	2.0	25.00	50.00
SP-26	EXPLORATORY TRENCH	CUYD	2.0	1.00	2.00
	<b>TOTAL BASE BID</b>				27,324.00

**BID 2 - PRAIRIE AND LINSCOTT NE**

ITEM NO.	ITEMS	UNIT	QNTY	UNIT PRICE	TOTAL PRICE
20101700	SUPPLEMENTAL WATERING	UNIT	1.0	250.00	250.00
67100100	MOBILIZATION	LSUM	1.0	2,220.00	2,220.00
44000600	SIDEWALK REMOVAL	SQ FT	535.0	2.00	1,070.00
SP-5	PRECONSTRUCTION VIDEOTAPING	LSUM	1.0	1.00	1.00
SP-6	CONSTRUCTION STAKING	LSUM	1.0	1.00	1.00
SP-7	TRAFFIC CONTROL, MAINTENANCE OF TRAFFIC, DETOURS	L SUM	1.0	1,000.00	1,000.00
SP-8	ADDITIONAL HAULING SURCHARGE, NON-HAZARDOUS SPECIAL WASTE	LOAD	1.0	250.00	250.00
SP-11	STREET SWEEPING AND DUST CONTROL	HOUR	2.0	50.00	100.00
SP-12	PORTLAND CEMENT CONCRETE SIDEWALK, 5 INCH	SQ FT	535.0	38.00	20,330.00
SP-13	DETECTABLE WARNINGS	SQ FT	20.0	40.00	800.00
SP-16	TREE ROOT PRUNING	FOOT	50.0	30.00	1,500.00
SP-17	AGGREGATE FOR TEMPORARY ACCESS	TON	2.0	20.00	40.00
SP-18	EARTH EXCAVATION, SPECIAL	CUYD	25.0	10.00	250.00
SP-19	WEED CONTROL, PRE-EMERGENT	LBS	1.0	50.00	50.00
SP-23	GROWTH-INHIBITING EROSION CONTROL BLANKET	SQYD	45.0	1.00	45.00
SP-23	SOD RESTORATION	SQYD	45.0	30.00	1,350.00
SP-24	INLET FILTERS	EACH	2.0	25.00	50.00
SP-25	MODULAR CONCRETE BLOCK RETAINING WALL	SQ FT	40.0	140.00	5,600.00
SP-26	EXPLORATORY TRENCH	CUYD	2.0	1.00	2.00
	<b>TOTAL BASE BID</b>				34,909.00

**BID 3 - PRAIRIE AND LINSCOTT NW**

ITEM NO.	ITEMS	UNIT	QNTY	UNIT PRICE	TOTAL PRICE
20101700	SUPPLEMENTAL WATERING	UNIT	1.0	250.00	250.00
67100100	MOBILIZATION	LSUM	1.0	2,220.00	2,220.00
44000600	SIDEWALK REMOVAL	SQ FT	495.0	2.00	990.00
SP-5	PRECONSTRUCTION VIDEOTAPING	LSUM	1.0	1.00	1.00
SP-6	CONSTRUCTION STAKING	LSUM	1.0	1.00	1.00
SP-7	TRAFFIC CONTROL, MAINTENANCE OF TRAFFIC, DETOURS	LSUM	1.0	1,000.00	1,000.00
SP-8	ADDITIONAL HAULING SURCHARGE, NON-HAZARDOUS SPECIAL WASTE	LOAD	1.0	250.00	250.00
SP-11	STREET SWEEPING AND DUST CONTROL	HOURL	2.0	50.00	100.00
SP-12	PORTLAND CEMENT CONCRETE SIDEWALK, 5 INCH	SQ FT	495.0	38.00	18,810.00
SP-13	DETECTABLE WARNINGS	SQ FT	20.0	40.00	800.00
SP-14	CONCRETE CURB, TYPE B-6"	FOOT	26.5	105.00	2,782.50
SP-16	TREE ROOT PRUNING	FOOT	25.0	30.00	750.00
SP-17	AGGREGATE FOR TEMPORARY ACCESS	TON	2.0	20.00	40.00
SP-18	EARTH EXCAVATION, SPECIAL	CUYD	15.0	10.00	150.00
SP-19	WEED CONTROL, PRE-EMERGENT	LBS	1.0	50.00	50.00
SP-23	GROWTH-INHIBITING EROSION CONTROL BLANKET	SQYD	45.0	1.00	45.00
SP-23	SOD RESTORATION	SQYD	45.0	30.00	1,350.00
SP-24	INLET FILTERS	EACH	2.0	25.00	50.00
SP-26	EXPLORATORY TRENCH	CUYD	2.0	1.00	2.00
	<b>TOTAL BASE BID</b>				<b>29,641.50</b>

BID 4 - PRAIRIE AND PRINCE SW

ITEM NO.	ITEMS	UNIT	QNTY	UNIT PRICE	TOTAL PRICE
67100100	MOBILIZATION	LSUM	1.0	2,076.00	2,076.00
20101700	SUPPLEMENTAL WATERING	UNIT	1.0	250.00	250.00
44000600	SIDEWALK REMOVAL	SQ FT	385.0	2.00	770.00
SP-5	PRECONSTRUCTION VIDEOTAPING	LSUM	1.0	1.00	1.00
SP-6	CONSTRUCTION STAKING	LSUM	1.0	1.00	1.00
SP-7	TRAFFIC CONTROL, MAINTENANCE OF TRAFFIC, DETOURS	LSUM	1.0	1,000.00	1,000.00
SP-8	ADDITIONAL HAULING SURCHARGE, NON-HAZARDOUS SPECIAL WASTE	LOAD	1.0	250.00	250.00
SP-11	STREET SWEEPING AND DUST CONTROL	HOUR	2.0	50.00	100.00
SP-12	PORTLAND CEMENT CONCRETE SIDEWALK, 5 INCH	SQ FT	385.0	38.00	14,630.00
SP-13	DETECTABLE WARNINGS	SQ FT	20.0	40.00	800.00
SP-14	CONCRETE CURB, TYPE B-6"	FOOT	25.0	105.00	2,625.00
SP-16	TREE ROOT PRUNING	FOOT	25.0	30.00	750.00
SP-17	AGGREGATE FOR TEMPORARY ACCESS	TON	2.0	20.00	40.00
SP-18	EARTH EXCAVATION, SPECIAL	CUYD	10.5	10.00	105.00
SP-19	WEED CONTROL, PRE-EMERGENT	LBS	1.0	50.00	50.00
SP-23	GROWTH-INHIBITING EROSION CONTROL BLANKET	SQYD	36.0	1.00	36.00
SP-23	SOD RESTORATION	SOYD	36.0	30.00	1,080.00
SP-24	INLET FILTERS	EACH	2.0	25.00	50.00
SP-26	EXPLORATORY TRENCH	CUYD	2.0	1.00	2.00
	<b>TOTAL BASE BID</b>				24,616.00

**BID 5 - PRAIRIE AND FOREST NW**

ITEM NO.	ITEMS	UNIT	QNTY	UNIT PRICE	TOTAL PRICE
20101700	SUPPLEMENTAL WATERING	UNIT	1.0	250.00	250.00
67100100	MOBILIZATION	LSUM	1.0	2,812.00	2,812.00
44000600	SIDEWALK REMOVAL	SQ FT	550.0	2.00	1,100.00
SP-5	PRECONSTRUCTION VIDEOTAPING	L SUM	1.0	1.00	1.00
SP-6	CONSTRUCTION STAKING	L SUM	1.0	1.00	1.00
SP-7	TRAFFIC CONTROL, MAINTENANCE OF TRAFFIC, DETOURS	LSUM	1.0	1,000.00	1,000.00
SP-8	ADDITIONAL HAULING SURCHARGE, NON-HAZARDOUS SPECIAL WASTE	LOAD	1.0	250.00	250.00
SP-11	STREET SWEEPING AND DUST CONTROL	HOUR	2.0	50.00	100.00
SP-12	PORTLAND CEMENT CONCRETE SIDEWALK, 5 INCH	SQ FT	550.0	38.00	20,900.00
SP-13	DETECTABLE WARNINGS	SQ FT	20.0	40.00	800.00
SP-15	DRAINAGE & UTILITY STRUCTURE TO BE ADJUSTED.	EACH	1.0	500.00	500.00
SP-16	TREE ROOT PRUNING	FOOT	50.0	30.00	1,500.00
SP-17	AGGREGATE FOR TEMPORARY ACCESS	TON	2.0	20.00	40.00
SP-18	EARTH EXCAVATION, SPECIAL	CUYD	25.0	10.00	250.00
SP-19	WEED CONTROL, PRE-EMERGENT	LBS	1.0	50.00	50.00
SP-23	GROWTH-INHIBITING EROSION CONTROL BLANKET	SQYD	82.0	1.00	82.00
SP-23	SOD RESTORATION	SQYD	82.0	30.00	2,460.00
SP-24	INLET FILTERS	EACH	2.0	25.00	50.00
SP-25	MODULAR CONCRETE BLOCK RETAINING WALL	SQ FT	30.0	140.00	4,200.00
SP-26	EXPLORATORY TRENCH	CUYD	2.0	1.00	2.00
	<b>TOTAL BASE BID</b>				36,348.00

**BID 6 - PRAIRIE AND FOREST SE**

ITEM NO.	ITEMS	UNIT	QNTY	UNIT PRICE	TOTAL PRICE
20101700	SUPPLEMENTAL WATERING	UNIT	1.0	250.00	250.00
67100100	MOBILIZATION	LSUM	1.0	2,460.00	2,460.00
44000600	SIDEWALK REMOVAL	SQ FT	560.0	2.00	1,120.00
SP-5	PRECONSTRUCTION VIDEOTAPING	L SUM	1.0	1.00	1.00
SP-6	CONSTRUCTION STAKING	L SUM	1.0	1.00	1.00
SP-7	TRAFFIC CONTROL, MAJNTENANCE OF TRAFFIC, DETOURS	LSUM	1.0	1,000.00	1,000.00
SP-8	ADDITIONAL HAULING SURCHARGE, NON-HAZARDOUS SPECIAL WASTE	LOAD	1.0	250.00	250.00
SP-11	STREET SWEEPING AND DUST CONTROL	HOUR	2.0	50.00	100.00
SP-12	PORTLAND CEMENT CONCRETE SIDEWALK, 5 INCH	SQ FT	560.0	38.00	21,280.00
SP-13	DETECTABLE WARNINGS	SQ FT	20.0	40.00	800.00
SP-14	CONCRETE CURB, TYPE B-6"	FOOT	75.0	105.00	7,875.00
SP-15	DRAINAGE & UTILITY STRUCTURE TO BE ADJUSTED.	EACH	2.0	500.00	1,000.00
SP-16	TREE ROOT PRUNING	FOOT	25.0	30.00	750.00
SP-17	AGGREGATE FOR TEMPORARY ACCESS	TON	2.0	20.00	40.00
SP-18	EARTH EXCAVATION, SPECIAL	CUYD	18.0	10.00	180.00
SP-19	WEED CONTROL, PRE-EMERGENT	LBS	1.0	50.00	50.00
SP-23	GROWTH-INHIBITING EROSION CONTROL BLANKET	SQYD	60.0	1.00	60.00
SP-23	SOD RESTORATION	SQYD	60.0	30.00	1,800.00
SP-24	INLET FILTERS	EACH	2.0	25.00	50.00
SP-26	EXPLORATORY TRENCH	CUYD	2.0	1.00	2.00
	<b>TOTAL BASE BID</b>				39,069.00

## BID 7 - HATCH AND CAMDEN SW

ITEM NO.	ITEMS	UNIT	QNTY	UNIT PRICE	TOTAL PRICE
20101700	SUPPLEMENTAL WATERING	UNIT	1.0	250.00	250.00
67100100	MOBILIZATION	LSUM	1.0	1,768.00	1,768.00
44000600	SIDEWALK REMOVAL	SQ FT	300.0	2.00	600.00
SP-5	PRECONSTRUCTION VIDEOTAPING	LSUM	1.0	1.00	1.00
SP-6	CONSTRUCTION STAKING	LSUM	1.0	1.00	1.00
SP-7	TRAFFIC CONTROL, MAINTENANCE OF TRAFFIC, DETOURS	L SUM	1.0	1,000.00	1,000.00
SP-8	ADDITIONAL HAULING SURCHARGE, NON-HAZARDOUS SPECIAL WASTE	LOAD	1.0	250.00	250.00
SP-11	STREET SWEEPING AND DUST CONTROL	HOUR	2.0	50.00	100.00
SP-12	PORTLAND CEMENT CONCRETE SIDEWALK, 5 INCH	SQ FT	300.0	38.00	11,400.00
SP-13	DETECTABLE WARNINGS	SQ FT	20.0	40.00	800.00
SP-14	CONCRETE CURB, TYPE B-6"	FOOT	31.0	105.00	3,255.00
SP-15	DRAINAGE & UTILITY STRUCTURE TO BE ADJUSTED.	EACH	2.0	500.00	1,000.00
SP-16	TREE ROOT PRUNING	FOOT	25.0	30.00	750.00
SP-17	AGGREGATE FOR TEMPORARY ACCESS	TON	2.0	20.00	40.00
SP-18	EARTH EXCAVATION, SPECIAL	CUYD	7.0	10.00	70.00
SP-19	WEED CONTROL, PRE-EMERGENT	LBS	1.0	50.00	50.00
SP-23	GROWTH-INHIBITING EROSION CONTROL BLANKET	SQYD	23.0	1.00	23.00
SP-23	SOD RESTORATION	SQYD	23.0	30.00	690.00
SP-24	INLET FILTERS	EACH	1.0	25.00	25.00
SP-26	EXPLORATORY TRENCH	CUYD	2.0	1.00	2.00
	<b>TOTAL BASE BID</b>				22,075.00

## BID 8 - HALL AND DEVEREUX NE

ITEM NO.	ITEMS	UNIT	QNTY	UNIT PRICE	TOTAL PRICE
20101700	SUPPLEMENTAL WATERING	UNIT	1.0	250.00	250.00
67100100	MOBILIZATION	LSUM	1.0	1,800.00	1,800.00
44000600	SIDEWALK REMOVAL	SQ FT	300.0	2.00	600.00
SP-5	PRECONSTRUCTION VIDEOTAPING	LSUM	1.0	1.00	1.00
SP-6	CONSTRUCTION STAKING	LSUM	1.0	1.00	1.00
SP-7	TRAFFIC CONTROL, MAINTENANCE OF TRAFFIC, DETOURS	LSUM	1.0	1,000.00	1,000.00
SP-8	ADDITIONAL HAULING SURCHARGE, NON-HAZARDOUS SPECIAL WASTE	LOAD	1.0	250.00	250.00
SP-11	STREET SWEEPING AND DUST CONTROL	HOUR	2.0	50.00	100.00
SP-12	PORTLAND CEMENT CONCRETE SIDEWALK, 5 INCH	SQ FT	300.0	38.00	11,400.00
SP-13	DETECTABLE WARNINGS	SQ FT	20.0	40.00	800.00
SP-14	CONCRETE CURB, TYPE B-6"	FOOT	28.0	105.00	2,940.00
SP-15	DRAINAGE & UTILITY STRUCTURE TO BE ADJUSTED.	EACH	1.0	500.00	500.00
SP-16	TREE ROOT PRUNING	FOOT	50.0	30.00	1,500.00
SP-17	AGGREGATE FOR TEMPORARY ACCESS	TON	2.0	20.00	40.00
SP-18	EARTH EXCAVATION, SPECIAL	CUYD	6.0	10.00	60.00
SP-19	WEED CONTROL, PRE-EMERGENT	LBS	1.0	50.00	50.00
SP-23	GROWTH-INHIBITING EROSION CONTROL BLANKET	SQYD	25.0	1.00	25.00
SP-23	SOD RESTORATION	SQYD	25.0	30.00	750.00
SP-24	INLET FILTERS	EACH	1.0	25.00	25.00
SP-26	EXPLORATORY TRENCH	CUYD	2.0	1.00	2.00
	<b>TOTAL BASE BID</b>				22,094.00

**BID 9 - BORMAN AND DEVEREUX NE**

ITEM NO.	ITEMS	UNIT	QNTY	UNIT PRICE	TOTAL PRICE
20101700	SUPPLEMENTAL WATERING	UNIT	1.0	250.00	250.00
67100100	MOBILIZATION	LSUM	1.0	1,656.00	1,656.00
44000600	SIDEWALK REMOVAL	SQ FT	205.0	2.00	410.00
SP-5	PRECONSTRUCTION VIDEOTAPING	LSUM	1.0	1.00	1.00
SP-6	CONSTRUCTION STAKING	LSUM	1.0	1.00	1.00
SP-7	TRAFFIC CONTROL, MAJNTENANCE OF TRAFFIC, DETOURS	LSUM	1.0	1,000.00	1,000.00
SP-8	ADDITIONAL HAULING SURCHARGE, NON-HAZARDOUS SPECIAL WASTE	LOAD	1.0	250.00	250.00
SP-11	STREET SWEEPING AND DUST CONTROL	HOUR	2.0	50.00	100.00
SP-12	PORTLAND CEMENT CONCRETE SIDEWALK, 5 INCH	SQ FT	205.0	38.00	7,790.00
SP-13	DETECTABLE WARNINGS	SQ FT	10.0	40.00	400.00
SP-14	CONCRETE CURB, TYPE B-6"	FOOT	19.0	105.00	1,995.00
SP-16	TREE ROOT PRUNING	FOOT	25.0	30.00	750.00
SP-17	AGGREGATE FOR TEMPORARY ACCESS	TON	2.0	20.00	40.00
SP-18	EARTH EXCAVATION, SPECIAL	CUYD	2.5	10.00	25.00
SP-19	WEED CONTROL, PRE-EMERGENT	LBS	1.0	50.00	50.00
SP-23	GROWTH-INHIBITING EROSION CONTROL BLANKET	SQYD	16.0	1.00	16.00
SP-23	SOD RESTORATION	SQYD	16.0	30.00	480.00
SP-24	INLET FILTERS	EACH	1.0	25.00	25.00
SP-26	EXPLORATORY TRENCH	CUYD	2.0	1.00	2.00
	<b>TOTAL BASE BID</b>				15,241.00

BID 10 - KLEIN AND BARRETT NE

ITEM NO.	ITEMS	UNIT	QNTY	UNIT PRICE	TOTAL PRICE
20101700	SUPPLEMENTAL WATERING	UNIT	1.0	250.00	250.00
67100100	MOBILIZATION	LSUM	1.0	1,988.00	1,988.00
44000600	SIDEWALK REMOVAL	SQ FT	475.0	2.00	950.00
SP-5	PRECONSTRUCTION VIDEOTAPING	L SUM	1.0	1.00	1.00
SP-6	CONSTRUCTION STAKING	LSUM	1.0	1.00	1.00
SP-7	TRAFFIC CONTROL, MAINTENANCE OF TRAFFIC, DETOURS	LSUM	1.0	1,000.00	1,000.00
SP-8	ADDITIONAL HAULING SURCHARGE, NON-HAZARDOUS SPECIAL WASTE	LOAD	1.0	250.00	250.00
SP-11	STREET SWEEPING AND DUST CONTROL	HOUR	2.0	50.00	100.00
SP-12	PORTLAND CEMENT CONCRETE SIDEWALK, 5 INCH	SQ FT	475.0	38.00	18,050.00
SP-13	DETECTABLE WARNINGS	SQ FT	20.0	40.00	800.00
SP-14	CONCRETE CURB, TYPE B-6"	FOOT	45.0	105.00	4,725.00
SP-16	TREE ROOT PRUNING	FOOT	25.0	30.00	750.00
SP-17	AGGREGATE FOR TEMPORARY ACCESS	TON	2.0	20.00	40.00
SP-18	EARTH EXCAVATION, SPECIAL	CUYD	18.0	10.00	180.00
SP-19	WEED CONTROL, PRE-EMERGENT	LBS	1.0	50.00	50.00
SP-23	GROWTH-INHIBITING EROSION CONTROL BLANKET	SQYD	43.0	1.00	43.00
SP-23	SOD RESTORATION	SQYD	43.0	30.00	1,290.00
SP-26	EXPLORATORY TRENCH	CUYD	2.0	1.00	2.00
	<b>TOTAL BASE BID</b>				30,470.00

**BID 11 - LANE & SUMMIT NE**

ITEM NO.	ITEMS	UNIT	QNTY	UNIT PRICE	TOTAL PRICE
20101700	SUPPLEMENTAL WATERING	UNIT	1.0	250.00	250.00
67100100	MOBILIZATION	LSUM	1.0	2,620.00	2,620.00
44000600	SIDEWALK REMOVAL	SQ FT	550.0	2.00	1,100.00
SP-5	PRECONSTRUCTION VIDEOTAPING	L SUM	1.0	1.00	1.00
SP-6	CONSTRUCTION STAKING	LSUM	1.0	1.00	1.00
SP-7	TRAFFIC CONTROL, MAINTENANCE OF TRAFFIC, DETOURS	LSUM	1.0	1,000.00	1,000.00
SP-8	ADDITIONAL HAULING SURCHARGE, NON-HAZARDOUS SPECIAL WASTE	LOAD	1.0	250.00	250.00
SP-11	STREET SWEEPING AND DUST CONTROL	HOUR	2.0	50.00	100.00
SP-12	PORTLAND CEMENT CONCRETE SIDEWALK, 5 INCH	SQ FT	550.0	38.00	20,900.00
SP-13	DETECTABLE WARNINGS	SQ FT	10.0	40.00	400.00
SP-15	DRAINAGE & UTILITY STRUCTURE TO BE ADJUSTED.	EACH	1.0	500.00	500.00
SP-16	TREE ROOT PRUNING	FOOT	50.0	30.00	1,500.00
SP-17	AGGREGATE FOR TEMPORARY ACCESS	TON	2.0	20.00	40.00
SP-18	EARTH EXCAVATION, SPECIAL	CUYD	25.0	10.00	250.00
SP-19	WEED CONTROL, PRE-EMERGENT	LBS	1.0	50.00	50.00
SP-23	GROWTH-INHIBITING EROSION CONTROL BLANKET	SQYD	70.0	1.00	70.00
SP-23	SOD RESTORATION	SQYD	70.0	30.00	2,100.00
SP-24	INLET FILTERS	EACH	2.0	25.00	50.00
SP-25	MODULAR CONCRETE BLOCK RETAINING WALL	SQ FT	37.0	140.00	5,180.00
SP-26	EXPLORATORY TRENCH	CUYD	2.0	1.00	2.00
SP-27	HOT-MIX ASPHALT DRIVEWAY REMOVAL & REPLACEMENT, 3"	SQYD	18.0	200.00	3,600.00
SP-28	PCC DRIVEWAY REMOVAL & REPLACEMENT, 6"	SQYD	14.0	40.00	560.00
	<b>TOTAL BASE BID</b>				40,524.00

**BID 12 - CHICAGO & SARATOGA NW**

ITEM NO.	ITEMS	UNIT	QNTY	UNIT PRICE	TOTAL PRICE
20101700	SUPPLEMENTAL WATERING	UNIT	2.0	250.00	500.00
67100100	MOBILIZATION	LSUM	1.0	3,692.00	3,692.00
44000600	SIDEWALK REMOVAL	SQ FT	600.0	2.00	1,200.00
44201690	CLASS D PATCHES, TYPE I, 4 INCH	SQYD	25.0	200.00	5,000.00
SP-5	PRECONSTRUCTION VIDEOTAPING	LSUM	1.0	1.00	1.00
SP-6	CONSTRUCTION STAKING	LSUM	1.0	1.00	1.00
SP-7	TRAFFIC CONTROL, MAINTENANCE OF TRAFFIC, DETOURS	LSUM	1.0	1,000.00	1,000.00
SP-8	ADDITIONAL HAULING SURCHARGE, NON-HAZARDOUS SPECIAL WASTE	LOAD	1.0	250.00	250.00
SP-11	STREET SWEEPING AND DUST CONTROL	HOURL	2.0	50.00	100.00
SP-12	PORTLAND CEMENT CONCRETE SIDEWALK, 5 INCH	SQ FT	600.0	38.00	22,800.00
SP-13	DETECTABLE WARNINGS	SQ FT	20.0	40.00	800.00
SP-14	CONCRETE CURB TYPE B, 6"	FOOT	90.0	105.00	9,450.00
SP-15	DRAINAGE & UTILITY STRUCTURE TO BE ADJUSTED.	EACH	1.0	500.00	500.00
SP-16	TREE ROOT PRUNING	FOOT	1.0	30.00	30.00
SP-17	AGGREGATE FOR TEMPORARY ACCESS	TON	1.0	20.00	20.00
SP-18	EARTH EXCAVATION, SPECIAL	CUYD	17.7	10.00	177.00
SP-19	WEED CONTROL, PRE-EMERGENT	LBS	1.0	50.00	50.00
SP-23	GROWTH-INHIBITING EROSION CONTROL BLANKET	SQYD	137.0	1.00	137.00
SP-23	SOD RESTORATION	SQYD	137.0	30.00	4,110.00
SP-24	INLET FILTERS	EACH	2.0	25.00	50.00
SP-26	EXPLORATORY TRENCH	CUYD	2.0	1.00	2.00
	<b>TOTAL BASE BID</b>				<b>49,870.00</b>

**BID 13 - 7TH & FAIRVIEW NE**

ITEM NO.	ITEMS	UNIT	QNTY	UNIT PRICE	TOTAL PRICE
20101700	SUPPLEMENTAL WATERING	UNIT	2.0	250.00	500.00
67100100	MOBILIZATION	LSUM	1.0	3,100.00	3,100.00
44000600	SIDEWALK REMOVAL	SQ FT	394.0	2.00	788.00
44201690	CLASS D PATCHES, TYPE I, 4INCH	SQYD	13.0	200.00	2,600.00
SP-5	PRECONSTRUCTION VIDEOTAPING	LSUM	1.0	1.00	1.00
SP-6	CONSTRUCTION STAKING	LSUM	1.0	1.00	1.00
SP-7	TRAFFIC CONTROL, MAINTENANCE OF TRAFFIC, DETOURS	LSUM	1.0	1,000.00	1,000.00
SP-8	ADDITIONAL HAULING SURCHARGE, NON-HAZARDOUS SPECIAL WASTE	LOAD	1.0	250.00	250.00
SP-11	STREET SWEEPING AND DUST CONTROL	HOUR	2.0	50.00	100.00
SP-12	PORTLAND CEMENT CONCRETE SIDEWALK, 5 INCH	SQ FT	394.0	38.00	14,972.00
SP-13	DETECTABLE WARNINGS	SQ FT	10.0	40.00	400.00
SP-14	CONCRETE CURB TYPE B, 6"	FOOT	25.0	105.00	2,625.00
SP-15	DRAINAGE & UTILITY STRUCTURE TO BE ADJUSTED.	EACH	1.0	500.00	500.00
SP-16	TREE ROOT PRUNING	FOOT	1.0	30.00	30.00
SP-17	AGGREGATE FOR TEMPORARY ACCESS	TON	1.0	20.00	20.00
SP-18	EARTH EXCAVATION, SPECIAL	CUYD	50.0	10.00	500.00
SP-19	WEED CONTROL, PRE-EMERGENT	LBS	1.0	50.00	50.00
SP-23	GROWTH-INHIBITING EROSION CONTROL BLANKET	SQYD	100.0	1.00	100.00
SP-23	SOD RESTORATION	SQYD	100.0	30.00	3,000.00
SP-24	INLET FILTERS	EACH	2.0	25.00	50.00
SP-25	MODULAR CONCRETE BLOCK RETAINING WALL	SQ FT	36.0	140.00	5,040.00
SP-26	EXPLORATORY TRENCH	CUYD	2.0	1.00	2.00
	<b>TOTAL BASE BID</b>				<b>35,629.00</b>

## BID 14 7TH &amp; FAIRVIEW SE

ITEM NO.	ITEMS	UNIT	QNTY	UNIT PRICE	TOTAL PRICE
20101700	SUPPLEMENTAL WATERING	UNIT	2.0	250.00	500.00
67100100	MOBILIZATION	LSUM	1.0	3,580.00	3,580.00
44000600	SIDEWALK REMOVAL	SQ FT	475.0	2.00	950.00
44201690	CLASS D PATCHES, TYPE I, 4INCH	SQYD	9.0	200.00	1,800.00
SP-5	PRECONSTRUCTION VIDEOTAPING	LSUM	1.0	1.00	1.00
SP-6	CONSTRUCTION STAKING	LSUM	1.0	1.00	1.00
SP-7	TRAFFIC CONTROL, MAINTENANCE OF TRAFFIC, DETOURS	LSUM	1.0	1,000.00	1,000.00
SP-8	ADDITIONAL HAULING SURCHARGE, NON-HAZARDOUS SPECIAL WASTE	LOAD	1.0	250.00	250.00
SP-11	STREET SWEEPING AND DUST CONTROL	HOUR	2.0	50.00	100.00
SP-12	PORTLAND CEMENT CONCRETE SIDEWALK, 5 INCH	SQ FT	475.0	38.00	18,050.00
SP-13	DETECTABLE WARNINGS	SQ FT	10.0	40.00	400.00
SP-14	CONCRETE CURB TYPE B, 6"	FOOT	100.0	105.00	10,500.00
SP-15	DRAINAGE & UTILITY STRUCTURE TO BE ADJUSTED.	EACH	1.0	500.00	500.00
SP-16	TREE ROOT PRUNING	FOOT	1.0	30.00	30.00
SP-17	AGGREGATE FOR TEMPORARY ACCESS	TON	1.0	20.00	20.00
SP-18	EARTH EXCAVATION, SPECIAL	CUYD	60.0	10.00	600.00
SP-19	WEED CONTROL, PRE-EMERGENT	LBS	1.0	50.00	50.00
SP-23	GROWTH-INHIBITING EROSION CONTROL BLANKET	SQYD	130.0	1.00	130.00
SP-23	SOD RESTORATION	SQYD	130.0	30.00	3,900.00
SP-24	INLET FILTERS	EACH	2.0	25.00	50.00
SP-26	EXPLORATORY TRENCH	CUYD	2.0	1.00	2.00
	<b>TOTAL BASE BID</b>				42,414.00

## BID ALT - VENARD &amp; RED BUD

ITEM NO.	ITEMS	UNIT	QNTY	UNIT PRICE	TOTAL PRICE
20101700	SUPPLEMENTAL WATERING	UNIT	2.0	250.00	500.00
67100100	MOBILIZATION	LSUM	1.0	3,356.00	3,356.00
44000600	SIDEWALK REMOVAL	SQ FT	600.0	2.00	1,200.00
44201690	CLASS D PATCHES, TYPE I, 4INCH	SQYD	3.0	200.00	600.00
SP-5	PRECONSTRUCTION VIDEOTAPING	LSUM	1.0	1.00	1.00
SP-6	CONSTRUCTION STAKING	LSUM	1.0	1.00	1.00
SP-7	TRAFFIC CONTROL, MAINTENANCE OF TRAFFIC, DETOURS	LSUM	1.0	1,000.00	1,000.00
SP-8	ADDITIONAL HAULING SURCHARGE, NON-HAZARDOUS SPECIAL WASTE	LOAD	1.0	250.00	250.00
SP-11	STREET SWEEPING AND DUST CONTROL	HOUR	2.0	50.00	100.00
SP-12	PORTLAND CEMENT CONCRETE SIDEWALK, 5 INCH	SQ FT	705.0	38.00	26,790.00
SP-13	DETECTABLE WARNINGS	SQ FT	20.0	40.00	800.00
SP-14	CONCRETE CURB TYPE B, 6"	FOOT	30.0	105.00	3,150.00
SP-15	DRAINAGE & UTILITY STRUCTURE TO BE ADJUSTED.	EACH	1.0	500.00	500.00
SP-16	TREE ROOT PRUNING	FOOT	1.0	30.00	30.00
SP-17	AGGREGATE FOR TEMPORARY ACCESS	TON	1.0	20.00	20.00
SP-18	EARTH EXCAVATION, SPECIAL	CUYD	17.7	10.00	177.00
SP-19	WEED CONTROL, PRE-EMERGENT	LBS	1.0	50.00	50.00
SP-23	GROWTH-INHIBITING EROSION CONTROL BLANKET	SQYD	116.0	1.00	116.00
SP-23	SOD RESTORATION	SQYD	116.0	30.00	3,480.00
SP-24	INLET FILTERS	EACH	2.0	25.00	50.00
SP-25	MODULAR CONCRETE BLOCK RETAINING WALL	SQ FT	35.0	140.00	4,900.00
SP-26	EXPLORATORY TRENCH	CUYD	2.0	1.00	2.00
	<b>TOTAL BASE BID</b>				47,073.00

## Village of Downers Grove – S-008-23 ROW ACCESSIBILITY IMPROVEMENTS

27,324.00 (TOTAL BID 1)

+ 34,909.00 (TOTAL BID 2)

+ 29,641.50 (TOTAL BID 3)

+ 24,616.00 (TOTAL BID 4)

+ 36,348.00 (TOTAL BID 5)

+ 39,069.00 (TOTAL BID 6)

+ 22,075.00 (TOTAL BID 7)

+ 22,044.00 (TOTAL BID 8)

+ 15,241.00 (TOTAL BID 9)

+ 30,470.00 (TOTAL BID 10)

+ 40,524.00 (TOTAL BID 11)

+ 49,870.00 (TOTAL BID 12)

+ 35,629.00 (TOTAL BID 13)

+ 42,414.00 (TOTAL BID 14)

+ 47,073.00 (TOTAL BID ALT)

=TOTAL BID

497,297.50
------------



Illinois Department of Transportation

Local Public Agency Proposal Bid Bond



Local Public Agency	County	Section Number
Village of Downers Grove	DuPage	

WE, Alliance Contractors, Inc., 1188 Lake Avenue, Woodstock, IL 60098 as PRINCIPAL, and Travelers Casualty and Surety of America, 215 Shuman Blvd., Naperville, IL 60563 as SURETY, are held jointly, severally and firmly bound unto the above Local Public Agency (hereafter referred to as "LPA") in the penal sum of 5% of the total bid price, or for the amount specified in the proposal documents in effect on the date of invitation for bids, whichever is the lesser sum. We bind ourselves, our heirs, executors, administrators, successors, and assigns, jointly pay to the LPA this sum under the conditions of this instrument.

WHEREAS THE CONDITION OF THE FOREGOING OBLIGATION IS SUCH that, the said PRINCIPAL is submitting a written proposal to the LPA acting through its awarding authority for the construction of the work designated as the above section.

THEREFORE if the proposal is accepted and a contract awarded to the PRINCIPAL by the LPA for the above designated section and the PRINCIPAL shall within fifteen (15) days after award enter into a formal contract, furnish surety guaranteeing the faithful performance of the work, and furnish evidence of the required insurance coverage, all as provided in the "Standard Specifications for Road and Bridge Construction" and applicable Supplemental Specifications, then this obligation shall become void; otherwise it shall remain in full force and effect.

IN THE EVENT the LPA determines the PRINCIPAL has failed to enter into a formal contract in compliance with any requirements set forth in the preceding paragraph, then the LPA acting through its awarding authority shall immediately be entitled to recover the full penal sum set out above, together with all court costs, all attorney fees, and any other expense of recovery.

IN TESTIMONY WHEREOF, the said PRINCIPAL and the said SURETY have caused this instrument to be signed by their respective officers this 22<sup>nd</sup> of February, 2023  
Day Month and Year

Principal

Company Name	
Alliance Contractors, Inc.	
Signature	Date
<i>Scott Marquart</i>	2/22/2023
Title	
Vice President	

Company Name	
Signature	Date
Title	

(If Principal is a joint venture of two or more contractors, the company names, and authorized signatures of each contractor must be affixed.)

Surety

Name of Surety
Travelers Casualty and Surety of America

Signature of Attorney-in-Fact	Date
<i>Kathleen Stewart</i>	2/22/23

STATE OF IL  
COUNTY OF

I Dawn L. Thibadeau, a Notary Public in and for said county do hereby certify that  
Scott A. Marquart and Kathleen Stewart

(Insert names of individuals signing on behalf of PRINCIPAL & SURETY)

who are each personally known to me to be the same persons whose names are subscribed to the foregoing instrument on behalf of PRINCIPAL and SURETY, appeared before me this day in person and acknowledged respectively, that they signed and delivered said instruments as their free and voluntary act for the uses and purposes therein set forth.

Given under my hand and notarial seal this 22<sup>nd</sup> day of February, 2023  
Day Month and Year

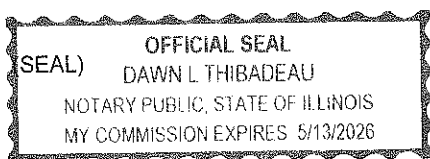

Notary Public Signature  
*D. Thibadeau*

Date commission expires 5/13/2026

Local Public Agency	County	Section Number

ELECTRONIC BID BOND

**Electronic bid bond is allowed (box must be checked by LPA if electronic bid bond is allowed)**

The Principal may submit an electronic bid bond, in lieu of completing the above section of the Proposal Bid Bond Form. By providing an electronic bid bond ID code and signing below, the Principal is ensuring the identified electronic bid bond has been executed and the Principal and Surety are firmly bound unto the LPA under the conditions of the bid bond as shown above. (If PRINCIPAL is a joint venture of two or more contractors, an electronic bid bond ID code, company/Bidder name title and date must be affixed for each contractor in the venture.)

Electronic Bid Bond ID Code

--	--	--	--	--	--	--	--	--	--	--	--	--	--	--	--	--	--	--	--

Company/Bidder Name

--

Signature	Date

Title

--



Travelers Casualty and Surety Company of America
Travelers Casualty and Surety Company
St. Paul Fire and Marine Insurance Company

POWER OF ATTORNEY

KNOW ALL MEN BY THESE PRESENTS: That Travelers Casualty and Surety Company of America, Travelers Casualty and Surety Company, and St. Paul Fire and Marine Insurance Company are corporations duly organized under the laws of the State of Connecticut (herein collectively called the "Companies"), and that the Companies do hereby make, constitute and appoint Kathleen Stewart of Chicago / Naperville Illinois, their true and lawful Attorney(s)-in-Fact to sign, execute, seal and acknowledge any and all bonds, recognizances, conditional undertakings and other writings obligatory in the nature thereof on behalf of the Companies in their business of guaranteeing the fidelity of persons, guaranteeing the performance of contracts and executing or guaranteeing bonds and undertakings required or permitted in any actions or proceedings allowed by law.

IN WITNESS WHEREOF, the Companies have caused this instrument to be signed, and their corporate seals to be hereto affixed, this 21st day of April, 2021.



State of Connecticut

City of Hartford ss.

By: [Signature] Robert L. Raney, Senior Vice President

On this the 21st day of April, 2021, before me personally appeared Robert L. Raney, who acknowledged himself to be the Senior Vice President of each of the Companies, and that he, as such, being authorized so to do, executed the foregoing instrument for the purposes therein contained by signing on behalf of said Companies by himself as a duly authorized officer.

IN WITNESS WHEREOF, I hereunto set my hand and official seal.

My Commission expires the 30th day of June, 2026

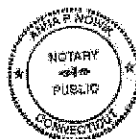

[Signature] Anna P. Nowik, Notary Public

This Power of Attorney is granted under and by the authority of the following resolutions adopted by the Boards of Directors of each of the Companies, which resolutions are now in full force and effect, reading as follows:

RESOLVED, that the Chairman, the President, any Vice Chairman, any Executive Vice President, any Senior Vice President, any Vice President, any Second Vice President, the Treasurer, any Assistant Treasurer, the Corporate Secretary or any Assistant Secretary may appoint Attorneys-in-Fact and Agents to act for and on behalf of the Company and may give such appointee such authority as his or her certificate of authority may prescribe to sign with the Company's name and seal with the Company's seal bonds, recognizances, contracts of indemnity, and other writings obligatory in the nature of a bond, recognizance, or conditional undertaking, and any of said officers or the Board of Directors at any time may remove any such appointee and revoke the power given him or her; and it is

FURTHER RESOLVED, that the Chairman, the President, any Vice Chairman, any Executive Vice President, any Senior Vice President or any Vice President may delegate all or any part of the foregoing authority to one or more officers or employees of this Company, provided that each such delegation is in writing and a copy thereof is filed in the office of the Secretary; and it is

FURTHER RESOLVED, that any bond, recognizance, contract of indemnity, or writing obligatory in the nature of a bond, recognizance, or conditional undertaking shall be valid and binding upon the Company when (a) signed by the President, any Vice Chairman, any Executive Vice President, any Senior Vice President or any Vice President, any Second Vice President, the Treasurer, any Assistant Treasurer, the Corporate Secretary or any Assistant Secretary and duly attested and sealed with the Company's seal by a Secretary or Assistant Secretary; or (b) duly executed (under seal, if required) by one or more Attorneys-in-Fact and Agents pursuant to the power prescribed in his or her certificate or their certificates of authority or by one or more Company officers pursuant to a written delegation of authority; and it is

FURTHER RESOLVED, that the signature of each of the following officers: President, any Executive Vice President, any Senior Vice President, any Vice President, any Assistant Vice President, any Secretary, any Assistant Secretary, and the seal of the Company may be affixed by facsimile to any Power of Attorney or to any certificate relating thereto appointing Resident Vice Presidents, Resident Assistant Secretaries or Attorneys-in-Fact for purposes only of executing and attesting bonds and undertakings and other writings obligatory in the nature thereof, and any such Power of Attorney or certificate bearing such facsimile signature or facsimile seal shall be valid and binding upon the Company and any such power so executed and certified by such facsimile signature and facsimile seal shall be valid and binding on the Company in the future with respect to any bond or understanding to which it is attached.

I, Kevin E. Hughes, the undersigned, Assistant Secretary of each of the Companies, do hereby certify that the above and foregoing is a true and correct copy of the Power of Attorney executed by said Companies, which remains in full force and effect.

Dated this 22nd day of February 2022



[Signature] Kevin E. Hughes, Assistant Secretary

To verify the authenticity of this Power of Attorney, please call us at 1-800-421-3880. Please refer to the above-named Attorney(s)-in-Fact and the details of the bond to which this Power of Attorney is attached.



Karena Rios  
Account Manager, Construction Services, Travelers Bond  
215 Shuman Blvd., Naperville, IL 60563  
Telephone: (630) 961-7162  
Fax: (866)216-5979  
Email: krios4@travelers.com

February 22, 2023

Village of Downers Grove  
5101 Walnut Ave.  
Downers Grove, IL 60515

**RE:** Alliance Contractors Inc.  
1166 Lake Avenue, Woodstock, IL 60098

**Project:** 2023 ROW Accessibility Improvements  
Downers Grove, IL

Ladies and Gentlemen:

We are pleased to share with you our experience as surety for ALLIANCE CONTRACTORS, INC. We consider ALLIANCE CONTRACTORS, INC. one of our outstanding and most valued clients in whom we have the highest confidence. Through the years this company has, in our opinion, remained properly financed, well equipped and capably managed.

TRAVELERS CASUALTY AND SURETY COMPANY OF AMERICA is prepared to give favorable consideration to the execution of contract performance and payment bonds running to the Owner, in association with the 2023 ROW Accessibility Improvements Project. We understand that ALLIANCE CONTRACTORS, INC.'S contract is in the \$7,000,000.00 Single to \$20,000,000.00 Aggregate range.

Our willingness to provide surety credit on this project is subject to ALLIANCE CONTRACTORS, INC.'S acceptance of an award of the contract, ALLIANCE CONTRACTORS, INC. applying to the TRAVELERS CASUALTY AND SURETY COMPANY OF AMERICA on or about the day work is scheduled to begin for bonding, and ALLIANCE CONTRACTORS, INC. and us, as surety, determining that the contract documents, contract specifications and bond forms are acceptable.

We are pleased to share with you our experience with this fine organization. If you require any additional information, please let us know.

Best regards,

TRAVELERS CASUALTY AND SURETY  
COMPANY OF AMERICA



Karena Rios  
Attorney-in-Fact





**Illinois Department  
of Transportation**

# Certificate of Eligibility

Contractor No 0103

Alliance Contractors, Inc.  
1166 Lake Avenue Woodstock, IL 60098

WHO HAS FILED WITH THE DEPARTMENT AN APPLICATION FOR PREQUALIFICATION STATEMENT OF EXPERIENCE, EQUIPMENT AND FINANCIAL CONDITION IS HEREBY QUALIFIED TO BID AT ANY OF DEPARTMENT OF TRANSPORTATION LETTINGS IN THE CLASSES OF WORK AND WITHIN THE AMOUNT AND OTHER LIMITATIONS OF EACH CLASSIFICATION, AS LISTED BELOW, FOR SUCH PERIOD AS THE UNCOMPLETED WORK FROM ALL SOURCES DOES NOT EXCEED \$101,597,000.00

001	EARTHWORK	\$6,775,000
002	PCC PAVING	\$21,350,000
005	HMA PAVING	\$625,000 B
012	DRAINAGE	\$3,525,000
014	ELECTRICAL	\$350,000
017	CONCRETE CONSTRUCTION	\$6,125,000
022	FENCING	\$100,000
023	GUARDRAIL	\$175,000
026	SIGNING	\$525,000
032	COLD MILL, PLAN. & ROTOMILL	\$450,000
034	DEMOLITION	\$400,000
08A	AGGREGATE BASES & SURF. (A)	\$2,750,000
09C	HWY., R.R. & WATERWAY STR.	\$5,650,000

THIS CERTIFICATE OF ELIGIBILITY IS VALID FROM 7/19/2022 TO 7/31/2023 INCLUSIVE, AND SUPERSEDES ANY CERTIFICATE PREVIOUSLY ISSUED, BUT IS SUBJECT TO REVISION OR REVOCATION, IF AND WHEN CHANGES IN THE FINANCIAL CONDITION OF THE CONTRACTING FIRM OR OTHER FACTS JUSTIFY SUCH REVISIONS OR REVOCATION. ISSUED AT SPRINGFIELD, ILLINOIS ON 7/19/2022.

B Restricted to 1200 tons in any 1 contract (Class I and/or BAM) or as specified by local agency

*[Signature]*  
Engineer of Construction

# Illinois Department of Transportation

## Affidavit of Availability

For the Letting of: Feb. 22, 2023

Bureau of Construction  
2300 South Dirksen Parkway/ Room 322  
Springfield, Illinois 62764

Instructions: Complete this form by either typing or using black ink. "Authorization to Bid" will not be issued unless both sides of this form are completed in detail. Use additional forms as needed to list all work.

### Part I. Work Under Contract

List below all work you have under contract as either a prime contractor or a subcontractor. It is required to include all pending low bids not yet awarded or rejected. In a joint venture, list only that portion of the work which is the responsibility of your company. The uncompleted dollar value is to be based upon the most recent engineer's or owners estimate, and must include work subcontracted to others. If no work is contracted, show **NONE**.

	1	2	3	4	Awards Pending	
	21024	Cont.	22001	Cont.		
Contract Number	62633		62K02			
Contract With	IDOT		IDOT			
Estimated Completion Date	5/1/2023		7/1/2023			Accumulated
Total Contract Price	\$4,496,491.00		\$2,935,409.00			Totals
Uncompleted Dollar Value if Firm is the Prime Contractor	\$46,480.00		\$275,876.00			\$322,356.00
Uncompleted Dollar Value if Firm is the Subcontractor						\$0.00
						\$322,356.00

### Part II. Awards Pending and Uncompleted Work to be done with your own forces.

List below the uncompleted dollar value of work for each contract and awards pending to be completed with your own forces. All work subcontracted to others will be listed on the reverse of this form. In a joint venture, list only that portion of the work to be done by your company. If no work is contracted, show **NONE**.

					Accumulated Totals
Earthwork			\$28,434.00		\$28,434.00
Portland Cement Concrete Paving					\$0.00
HMA Plant Mix					\$0.00
HMA Paving					\$0.00
Clean & Seal Cracks / Joints					\$0.00
Aggregate Bases & Surfaces			\$7,216.00		\$7,216.00
Highway, R.R. and Waterway Structures					\$0.00
Drainage					\$0.00
Electrical					\$0.00
Cover and Seal Coats					\$0.00
Concrete Construction	\$4,325.00		\$198,010.00		\$202,335.00
Landscaping					\$0.00
Fencing					\$0.00
Guardrail					\$0.00
Temp Soil Retention	22nd				\$0.00
Sound Wall	February	\$2,023.00			\$2,023.00
Cold Milling, Planning & Rotomilling					\$0.00
Demolition					\$0.00
Pavement Markings (Paint)					\$0.00
Signing					\$0.00
Layout					\$0.00
<b>Totals</b>	\$4,325.00	\$2,023.00	\$233,660.00	\$0.00	\$0.00

Disclosure of this information is **REQUIRED** to accomplish the statutory purpose as outlined in the "Illinois Procurement Code". Failure to comply will result in non-issuance of an "Authorization To Bid." This form has been approved by the State Forms Management Center.

Part III. Work Subcontracted to Others.

Feb. 22, 2023

For each contract described in Part 1, list all the work you have subcontracted to others.

	1	Cont.	3	Cont.	Awards Pending
Subcontractor	Resource Illinois	Clean Cut	Schroeder	Mackie	
Type of Work	Spl Waste	Tree Removal	Asphalt	Const. Layout	
Subcontract Price	\$87,700.00	\$5,970.00	\$638,575.00	\$15,900.00	
Amount Uncompleted	\$0.00	\$0.00	\$0.00	\$0.00	
Subcontractor	Galaxy	LPS	Elmund Nelson	Lands. By G. Weiss	
Type of Work	SS	Brick	Electrical	Landscaping	
Subcontract Price	\$52,165.00	\$39,744.00	\$724,624.00	\$38,268.00	
Amount Uncompleted	\$0.00	\$0.00	\$0.00	\$0.00	
Subcontractor	D2K	Mackie	Horvath		
Type of Work	Traffic Control	Const. Layout	Spl Waste		
Subcontract Price	\$381,096.00	\$34,900.00	\$88,400.00		
Amount Uncompleted	\$0.00	\$0.00	\$0.00		
Subcontractor	Peter Baker	Home Towne	D2K		
Type of Work	Asphalt	Electrical	Pvt Marking		
Subcontract Price	\$1,035,928.00	\$1,103,289.00	\$29,656.00		
Amount Uncompleted	\$0.00	\$42,155.00	\$29,656.00		
Subcontractor	Espinoza		Traffic Contr & Prot		
Type of Work	Landscaping		Traffic Control		
Subcontract Price	\$33,119.00		\$107,570.00		
Amount Uncompleted	\$0.00		\$12,560.00		
Total Uncompleted	\$0.00	\$42,155.00	\$42,216.00	\$0.00	\$0.00

I, being duly sworn, do hereby declare that this affidavit is a true and correct statement relating to ALL uncompleted contracts of the undersigned for Federal, State, County, City and private work, including ALL subcontract work, ALL pending low bids not yet awarded or rejected and ALL estimated completion dates.

Subscribed and sworn to before me  
 this 22nd day of  
February 2023

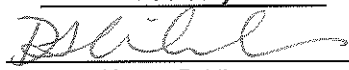
  
 Notary Public

My commission expires 5/13/2026



Type or Print Name Scott A. Marquart, Vice President  
 Officer or director Title

Signed 

Company Alliance Contractors, Inc.

Address 1166 Lake Avenue  
Woodstock, Illinois 60098

# Illinois Department of Transportation

## Affidavit of Availability

For the Letting of: Feb. 22, 2023

Bureau of Construction  
2300 South Dirksen Parkway/ Room 322  
Springfield, Illinois 62764

Instructions: Complete this form by either typing or using black ink. "Authorization to Bid" will not be issued unless both sides of this form are completed in detail. Use additional forms as needed to list all work.

### Part I. Work Under Contract

List below all work you have under contract as either a prime contractor or a subcontractor. It is required to include all pending low bids not yet awarded or rejected. In a joint venture, list only that portion of the work which is the responsibility of your company. The uncompleted dollar value is to be based upon the most recent engineer's or owners estimate, and must include work subcontracted to others. If no work is contracted, show **NONE**.

	5 22009	6 Cont.	7 Cont.	8 22011	Cont.	
Contract Number	61H35			61E87		
Contract With	IDOT			IDOT		
Estimated Completion Date	6/1/2023			12/1/2023		Accumulated
Total Contract Price	\$1,093,662.00			\$4,371,729.00		Totals
Uncompleted Dollar Value if Firm is the Prime Contractor	\$568,559.00			\$4,371,729.00		\$5,262,644.00
Uncompleted Dollar Value if Firm is the Subcontractor						\$0.00
						\$5,262,644.00

### Part II. Awards Pending and Uncompleted Work to be done with your own forces.

List below the uncompleted dollar value of work for each contract and awards pending to be completed with your own forces. All work subcontracted to others will be listed on the reverse of this form. In a joint venture, list only that portion of the work to be done by your company. If no work is contracted, show **NONE**.

					Accumulated Totals
Earthwork	\$56,412.00			\$565,263.00	\$650,109.00
Portland Cement Concrete Paving	\$34,088.00			\$290,213.00	\$324,301.00
HMA Plant Mix					\$0.00
HMA Paving					\$0.00
Clean & Seal Cracks / Joints					\$0.00
Aggregate Bases & Surfaces	\$6,547.00			\$115,997.00	\$129,760.00
Highway, R.R. and Waterway Structures					\$0.00
Drainage					\$0.00
Electrical					\$0.00
Cover and Seal Coats					\$0.00
Concrete Construction	\$57,089.00			\$273,315.00	\$532,739.00
Landscaping					\$0.00
Fencing					\$0.00
Guardrail					\$0.00
Temp Soil Retention	22nd				\$0.00
Sound Wall	February	\$2,023.00			\$4,046.00
Cold Milling, Planning & Rotomilling					\$0.00
Demolition					\$0.00
Pavement Markings (Paint)					\$0.00
Signing					\$0.00
Layout					\$0.00
<b>Totals</b>	<b>\$154,136.00</b>	<b>\$2,023.00</b>	<b>\$0.00</b>	<b>\$1,244,788.00</b>	<b>\$0.00</b>
					<b>\$1,640,955.00</b>

Disclosure of this information is **REQUIRED** to accomplish the statutory purpose as outlined in the "Illinois Procurement Code". Failure to comply will result in non-issuance of an "Authorization To Bid." This form has been approved by the State Forms Management Center.

**Part III. Work Subcontracted to Others.**

Feb. 22, 2023

For each contract described in Part 1, list all the work you have subcontracted to others.

	5	Cont.	Cont.	8	Cont.
Subcontractor	Homer	Western Remac	Metromex	Resource Cons.	Traffic Contr & Prot
Type of Work	Tree Removal	Signage	Asphalt	Spl Waste	Traffic Control
Subcontract Price	\$8,453.00	\$24,408.00	\$111,580.00	\$24,625.00	\$133,163.00
Amount Uncompleted	\$0.00	\$24,408.00	\$111,580.00	\$24,625.00	\$133,163.00
Subcontractor	Resource Cons.	Utility Dynamics		Lands. By G Weiss	Ray Edwards
Type of Work	Spl Waste	Electrical		Landscaping	Underground
Subcontract Price	\$76,522.00	\$170,368.00		\$300,000.00	\$601,087.00
Amount Uncompleted	\$16,724.00	\$112,045.00		\$300,000.00	\$601,087.00
Subcontractor	Quigg Eng.	Work Zone Safety		Clean Cut	Home Towne
Type of Work	Const. Layout	Traffic Control		Tree Removal	Electrical
Subcontract Price	\$5,965.00	\$39,282.00		\$5,375.00	\$669,567.00
Amount Uncompleted	\$1,965.00	\$21,715.00		\$5,375.00	\$669,567.00
Subcontractor	A. Horn	Conin		Mackie Cons.	Northern
Type of Work	Masonry	Landscaping		Const. Layout	Railing
Subcontract Price	\$62,920.00	\$40,230.00		\$22,500.00	\$131,232.00
Amount Uncompleted	\$62,920.00	\$40,230.00		\$22,500.00	\$131,232.00
Subcontractor	Northern	Marking Spec.		Traffic Control Co.	Schroeder
Type of Work	Railing	Pvt Marking		Pvt Marking	Asphalt
Subcontract Price	\$8,000.00	\$14,836.00		\$24,392.00	\$1,215,000.00
Amount Uncompleted	\$8,000.00	\$14,836.00		\$24,392.00	\$1,215,000.00
<b>Total Uncompleted</b>	<b>\$89,609.00</b>	<b>\$213,234.00</b>	<b>\$111,580.00</b>	<b>\$376,892.00</b>	<b>\$2,750,049.00</b>

I, being duly sworn, do hereby declare that this affidavit is a true and correct statement relating to ALL uncompleted contracts of the undersigned for Federal, State, County, City and private work, including ALL subcontract work, ALL pending low bids not yet awarded or rejected and ALL estimated completion dates.

Subscribed and sworn to before me  
 this 22nd day of  
February 2023

*[Signature]*  
 Notary Public

My commission expires 5/13/2026

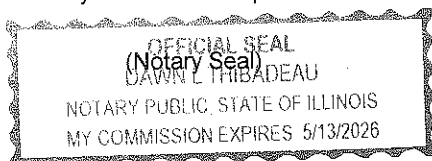

Type or Print Name Scott A. Marquart, Vice President  
Officer or director Title

Signed *[Signature]*

Company Alliance Contractors, Inc.

Address 1166 Lake Avenue  
Woodstock, Illinois 60098

# Illinois Department of Transportation

## Affidavit of Availability

For the Letting of: Feb. 22, 2023

Bureau of Construction  
2300 South Dirksen Parkway/ Room 322  
Springfield, Illinois 62764

Instructions: Complete this form by either typing or using black ink. "Authorization to Bid" will not be issued unless both sides of this form are completed in detail. Use additional forms as needed to list all work.

### Part I. Work Under Contract

List below all work you have under contract as either a prime contractor or a subcontractor. It is required to include all pending low bids not yet awarded or rejected. In a joint venture, list only that portion of the work which is the responsibility of your company. The uncompleted dollar value is to be based upon the most recent engineer's or owners estimate, and must include work subcontracted to others. If no work is contracted, show **NONE**.

	9 22016	10 Cont.	11 22017	12 22018	Awards Pending	
Contract Number	62D30		61H61			
Contract With	IDOT		Home Towne	DuPage Co. Forest Preserve		
Estimated Completion Date	8/1/2023		6/1/2023	5/15/2023		Accumulated
Total Contract Price	\$6,228,576.00		\$14,391.00	\$1,264,628.00		Totals
Uncompleted Dollar Value if Firm is the Prime Contractor	\$6,228,576.00		\$14,391.00	\$123,964.00		\$11,629,575.00
Uncompleted Dollar Value if Firm is the Subcontractor						\$0.00
	Total Value of Work					\$11,629,575.00

### Part II. Awards Pending and Uncompleted Work to be done with your own forces.

List below the uncompleted dollar value of work for each contract and awards pending to be completed with your own forces. All work subcontracted to others will be listed on the reverse of this form. In a joint venture, list only that portion of the work to be done by your company. If no work is contracted, show **NONE**.

					Accumulated Totals	
Earthwork	\$636,486.00		\$5,632.00		\$1,292,227.00	
Portland Cement Concrete Paving	\$1,690,967.00				\$2,015,266.00	
HMA Plant Mix					\$0.00	
HMA Paving					\$0.00	
Clean & Seal Cracks / Joints					\$0.00	
Aggregate Bases & Surfaces	\$204,949.00				\$334,709.00	
Highway, R.R. and Waterway Structures	\$190,870.00			\$10,244.00	\$201,114.00	
Drainage	\$142,290.00				\$142,290.00	
Electrical					\$0.00	
Cover and Seal Coats					\$0.00	
Concrete Construction	\$275,886.00		\$8,759.00		\$817,384.00	
Landscaping					\$0.00	
Fencing					\$0.00	
Guardrail					\$0.00	
Temp Soil Retention	22nd				\$0.00	
Sound Wall	February	\$2,023.00			\$6,069.00	
Cold Milling, Planning & Rotomilling					\$0.00	
Demolition					\$0.00	
Pavement Markings (Paint)					\$0.00	
Signing					\$0.00	
Layout					\$0.00	
<b>Totals</b>	\$3,141,448.00	\$2,023.00	\$14,391.00	\$10,244.00	\$0.00	\$4,809,061.00

Disclosure of this information is **REQUIRED** to accomplish the statutory purpose as outlined in the "Illinois Procurement Code". Failure to comply will result in non-issuance of an "Authorization To Bid." This form has been approved by the State Forms Management Center.

Part III. Work Subcontracted to Others.

Feb. 22, 2023

For each contract described in Part 1, list all the work you have subcontracted to others.

	9	Cont.	11	12	Awards Pending
Subcontractor	JA Johnson	Traf Contr & Prot		McGinty	
Type of Work	Asphalt	Traffic Control		Landscaping	
Subcontract Price	\$270,148.00	\$252,202.00		\$26,234.00	
Amount Uncompleted	<b>\$270,148.00</b>	<b>\$252,202.00</b>		<b>\$0.00</b>	
Subcontractor	Home Towne	Lands, by G Weiss		Bach Steel	
Type of Work	Electrical	Landscaping		Iron Work	
Subcontract Price	\$707,753.00	\$198,156.00		\$384,829.00	
Amount Uncompleted	<b>\$707,753.00</b>	<b>\$198,156.00</b>		<b>\$113,720.00</b>	
Subcontractor	Abitua	Geo Eng.		Mackie	
Type of Work	Underground	Spl Waste		Const. Layout	
Subcontract Price	\$1,483,904.00	\$32,350.00		\$5,800.00	
Amount Uncompleted	<b>\$1,483,904.00</b>	<b>\$32,350.00</b>		<b>\$0.00</b>	
Subcontractor	CES	Clean Cut			
Type of Work	Const. Layout	Tree Removal			
Subcontract Price	\$36,450.00	\$31,830.00			
Amount Uncompleted	<b>\$36,450.00</b>	<b>\$31,830.00</b>			
Subcontractor	Precision	Northern			
Type of Work	Pvt Marking	Railing			
Subcontract Price	\$40,899.00	\$33,436.00			
Amount Uncompleted	<b>\$40,899.00</b>	<b>\$33,436.00</b>			
Total Uncompleted	\$2,539,154.00	\$547,974.00	\$0.00	\$113,720.00	\$0.00

I, being duly sworn, do hereby declare that this affidavit is a true and correct statement relating to ALL uncompleted contracts of the undersigned for Federal, State, County, City and private work, including ALL subcontract work, ALL pending low bids not yet awarded or rejected and ALL estimated completion dates.

Subscribed and sworn to before me  
 this 22nd day of  
February 2023

  
 Notary Public

My commission expires 5/13/2026



Type or Print Name Scott A. Marquart, Vice President  
 Officer or director Title

Signed 

Company Alliance Contractors, Inc.

Address 1166 Lake Avenue  
Woodstock, Illinois 60098

# Illinois Department of Transportation

## Affidavit of Availability

For the Letting of: Feb. 22, 2023

Bureau of Construction  
2300 South Dirksen Parkway/ Room 322  
Springfield, Illinois 62764

Instructions: Complete this form by either typing or using black ink. "Authorization to Bid" will not be issued unless both sides of this form are completed in detail. Use additional forms as needed to list all work.

### Part I. Work Under Contract

List below all work you have under contract as either a prime contractor or a subcontractor. It is required to include all pending low bids not yet awarded or rejected. In a joint venture, list only that portion of the work which is the responsibility of your company. The uncompleted dollar value is to be based upon the most recent engineer's or owners estimate, and must include work subcontracted to others. If no work is contracted, show **NONE**.

	13 22023	14 Cont.	15 22036	16 Cont.	Awards Pending	
Contract Number	61H71		61H44			
Contract With	IDOT		IDOT			
Estimated Completion Date	10/1/2023		10/1/2023			Accumulated
Total Contract Price	\$5,262,614.00		\$8,264,103.00			Totals
Uncompleted Dollar Value if Firm is the Prime Contractor	\$5,262,614.00		\$8,264,103.00			\$25,156,292.00
Uncompleted Dollar Value if Firm is the Subcontractor						\$0.00
						\$25,156,292.00

### Part II. Awards Pending and Uncompleted Work to be done with your own forces.

List below the uncompleted dollar value of work for each contract and awards pending to be completed with your own forces. All work subcontracted to others will be listed on the reverse of this form. In a joint venture, list only that portion of the work to be done by your company. If no work is contracted, show **NONE**.

					Accumulated Totals	
Earthwork	\$470,195.00		\$774,279.00		\$2,536,701.00	
Portland Cement Concrete Paving	\$798,080.00		\$1,199,369.00		\$4,012,717.00	
HMA Plant Mix					\$0.00	
HMA Paving					\$0.00	
Clean & Seal Cracks / Joints					\$0.00	
Aggregate Bases & Surfaces	\$401,264.00		\$417,971.00		\$1,153,944.00	
Highway, R.R. and Waterway Structures			\$218,751.00		\$419,865.00	
Drainage	\$1,130,400.00		\$467,050.00		\$1,739,740.00	
Electrical					\$0.00	
Cover and Seal Coats					\$0.00	
Concrete Construction	\$413,438.00		\$617,461.00		\$1,848,283.00	
Landscaping					\$0.00	
Fencing					\$0.00	
Guardrail					\$0.00	
Temp Soil Retention	22nd				\$0.00	
Sound Wall	February	\$2,023.00			\$8,092.00	
Cold Milling, Planning & Rotomilling					\$0.00	
Demolition					\$0.00	
Pavement Markings (Paint)					\$0.00	
Signing					\$0.00	
Layout					\$0.00	
Totals	\$3,213,377.00	\$2,023.00	\$3,694,881.00	\$0.00	\$0.00	\$11,719,342.00

Disclosure of this information is **REQUIRED** to accomplish the statutory purpose as outlined in the "Illinois Procurement Code". Failure to comply will result in non-issuance of an "Authorization To Bid." This form has been approved by the State Forms Management Center.

Part III. Work Subcontracted to Others.

Feb. 22, 2023

For each contract described in Part 1, list all the work you have subcontracted to others.

	13	Cont.	15	Cont.	Awards Pending
Subcontractor	JEM	Homer	Home Towne	Traffic Contr & Prot	
Type of Work	Traffic Control	Tree Removal	Electrical	Traffic Control	
Subcontract Price	\$175,172.00	\$16,493.00	\$3,061,118.00	\$147,394.00	
Amount Uncompleted	<b>\$175,172.00</b>	<b>\$16,493.00</b>	<b>\$3,061,118.00</b>	<b>\$147,394.00</b>	
Subcontractor	Metromex	Roadway Lines	McGinty	Maint Coatings	
Type of Work	Asphalt	Pvt Marking	Tree Rem	Pvt Marking	
Subcontract Price	\$559,715.00	\$21,595.00	\$9,792.00	\$60,976.00	
Amount Uncompleted	<b>\$559,715.00</b>	<b>\$21,595.00</b>	<b>\$9,792.00</b>	<b>\$60,976.00</b>	
Subcontractor	Berger	Arteaga	Arteaga	Schroeder	
Type of Work	Underground	Landscaping	Landscaping	Asphalt	
Subcontract Price	\$640,220.00	\$155,021.00	\$69,908.00	\$960,742.00	
Amount Uncompleted	<b>\$640,220.00</b>	<b>\$155,021.00</b>	<b>\$69,908.00</b>	<b>\$960,742.00</b>	
Subcontractor	Resource III.	Elmund Nelson	Brownfield	Surface Const.	
Type of Work	Spl Waste	Electrical	Spl Waste	Asphalt Stamping	
Subcontract Price	\$15,500.00	\$450,031.00	\$35,800.00	\$179,329.00	
Amount Uncompleted	<b>\$15,500.00</b>	<b>\$450,031.00</b>	<b>\$35,800.00</b>	<b>\$179,329.00</b>	
Subcontractor	Quigg		Mackie	LPS	
Type of Work	Const. Layout		Const. Layout	Brick	
Subcontract Price	\$15,490.00		\$29,500.00	\$14,663.00	
Amount Uncompleted	<b>\$15,490.00</b>		<b>\$29,500.00</b>	<b>\$14,663.00</b>	
Total Uncompleted	\$1,406,097.00	\$643,140.00	\$3,206,118.00	\$1,363,104.00	\$0.00

I, being duly sworn, do hereby declare that this affidavit is a true and correct statement relating to ALL uncompleted contracts of the undersigned for Federal, State, County, City and private work, including ALL subcontract work, ALL pending low bids not yet awarded or rejected and ALL estimated completion dates.

Subscribed and sworn to before me  
 this 22nd day of  
February 2023

  
 Notary Public

My commission expires 5/13/2026

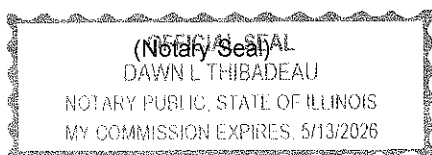

Type or Print Name Scott A. Marquart, Vice President  
 Officer or director Title

Signed 

Company Alliance Contractors, Inc.

Address 1166 Lake Avenue  
Woodstock, Illinois 60098

# Illinois Department of Transportation

## Affidavit of Availability

For the Letting of: Feb. 22, 2023

Bureau of Construction  
2300 South Dirksen Parkway/ Room 322  
Springfield, Illinois 62764

Instructions: Complete this form by either typing or using black ink. "Authorization to Bid" will not be issued unless both sides of this form are completed in detail. Use additional forms as needed to list all work.

### Part I. Work Under Contract

List below all work you have under contract as either a prime contractor or a subcontractor. It is required to include all pending low bids not yet awarded or rejected. In a joint venture, list only that portion of the work which is the responsibility of your company. The uncompleted dollar value is to be based upon the most recent engineer's or owners estimate, and must include work subcontracted to others. If no work is contracted, show **NONE**.

	17 22052	18 Cont.	19 23002	20	Awards Pending 23001	
Contract Number						
Contract With	Carol Stream		Bolder		Campanella	
Estimated Completion Date	6/30/2023		8/1/2023		8/1/2023	Accumulated
Total Contract Price	\$452,315.00		\$32,300.00		\$190,440.00	Totals
Uncompleted Dollar Value if Firm is the Prime Contractor	\$452,315.00					\$25,608,607.00
Uncompleted Dollar Value if Firm is the Subcontractor			\$32,300.00		\$190,440.00	\$222,740.00
Total Value of Work						\$25,831,347.00

### Part II. Awards Pending and Uncompleted Work to be done with your own forces.

List below the uncompleted dollar value of work for each contract and awards pending to be completed with your own forces. All work subcontracted to others will be listed on the reverse of this form. In a joint venture, list only that portion of the work to be done by your company. If no work is contracted, show **NONE**.

					Accumulated Totals	
Earthwork	\$44,816.00				\$2,581,517.00	
Portland Cement Concrete Paving					\$4,012,717.00	
HMA Plant Mix					\$0.00	
HMA Paving					\$0.00	
Clean & Seal Cracks / Joints					\$0.00	
Aggregate Bases & Surfaces	\$17,087.00				\$1,171,031.00	
Highway, R.R. and Waterway Structures	\$209,163.00				\$629,028.00	
Drainage	\$72,120.00				\$1,811,860.00	
Electrical					\$0.00	
Cover and Seal Coats					\$0.00	
Concrete Construction			\$32,300.00	\$190,440.00	\$2,071,023.00	
Landscaping					\$0.00	
Fencing					\$0.00	
Guardrail					\$0.00	
Temp Soil Retention	22nd				\$0.00	
Sound Wall	February	\$2,023.00			\$10,115.00	
Cold Milling, Planning & Rotomilling					\$0.00	
Demolition					\$0.00	
Pavement Markings (Paint)					\$0.00	
Signing					\$0.00	
Layout					\$0.00	
<b>Totals</b>	<b>\$343,186.00</b>	<b>\$2,023.00</b>	<b>\$32,300.00</b>	<b>\$0.00</b>	<b>\$190,440.00</b>	<b>\$12,287,291.00</b>

Disclosure of this information is **REQUIRED** to accomplish the statutory purpose as outlined in the "Illinois Procurement Code". Failure to comply will result in non-issuance of an "Authorization To Bid." This form has been approved by the State Forms Management Center.

**Part III. Work Subcontracted to Others.**

Feb. 22, 2023

For each contract described in Part 1, list all the work you have subcontracted to others.

	17	Cont.	19	20	Awards Pending
Subcontractor	TAT	Work Zone Safety			
Type of Work	Asphalt	Traffic Control			
Subcontract Price	\$33,149.00	\$10,400.00			
Amount Uncompleted	<b>\$33,149.00</b>	<b>\$10,400.00</b>			
Subcontractor	Sincere	Hamilton			
Type of Work	Landscaping	Const. Layout			
Subcontract Price	\$10,685.00	\$4,180.00			
Amount Uncompleted	<b>\$10,685.00</b>	<b>\$4,180.00</b>			
Subcontractor	Clean Cut	MA Rebar			
Type of Work	Tree Removal	Rebar Setting			
Subcontract Price	\$3,120.00	\$17,000.00			
Amount Uncompleted	<b>\$3,120.00</b>	<b>\$17,000.00</b>			
Subcontractor	Northern				
Type of Work	Railing				
Subcontract Price	\$23,115.00				
Amount Uncompleted	<b>\$23,115.00</b>				
Subcontractor	AC				
Type of Work	Pavt Marking				
Subcontract Price	\$7,480.00				
Amount Uncompleted	<b>\$7,480.00</b>				
<b>Total Uncompleted</b>	<b>\$77,549.00</b>	<b>\$31,580.00</b>	<b>\$0.00</b>	<b>\$0.00</b>	<b>\$0.00</b>

I, being duly sworn, do hereby declare that this affidavit is a true and correct statement relating to ALL uncompleted contracts of the undersigned for Federal, State, County, City and private work, including ALL subcontract work, ALL pending low bids not yet awarded or rejected and ALL estimated completion dates.

Subscribed and sworn to before me  
 this 22nd day of  
February 2023

  
 Notary Public

My commission expires 5/13/2026

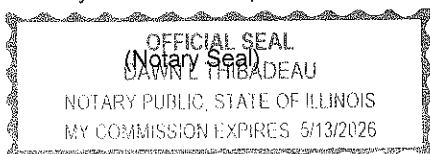

Type or Print Name Scott A. Marquart, Vice President  
 Officer or director Title

Signed 

Company Alliance Contractors, Inc.

Address 1166 Lake Avenue  
Woodstock, Illinois 60098

## Village of Downers Grove – S-008-23 ROW ACCESSIBILITY IMPROVEMENTS

**BIDDER'S CERTIFICATION (page 1 of 3)**

With regard to 2023 ROW Accessibility Improvements, Bidder Alliance Contractors, Inc.  
 (Name of Project) (Name of Bidder)

hereby certifies the following:

1. Bidder is not barred from bidding this Contract as a result of violations of Section 720 ILCS 5/33E-3 (Bid Rigging) or 720 ILCS 5/33E-4 (Bid-Rotating);
2. Bidder certifies that it has a written sexual harassment policy in place and full compliance with 775 ILCS 5/2-105(A)(4);
3. Bidder certifies that not less than the prevailing rate of wages as determined by the Village of Downers Grove, DuPage County or the Illinois Department of Labor shall be paid to all laborers, workers and mechanics performing work for the Village of Downers Grove. All bonds shall include a provision as will guarantee the faithful performance of such prevailing wage clause. Bidder agrees to comply with the Illinois Prevailing Wage Act, 820 ILCS 130/1 et seq., for all work completed. Bidder agrees to pay the prevailing wage and require that all of its subcontractors pay prevailing wage to any laborers, workers or mechanics who perform work pursuant to this Contract or related subcontract. Bidder and each subcontractor shall keep or cause to be kept an accurate record of each worker's name, address, telephone number when available, the last four digits of the worker's social security number, gender, race, ethnicity, veteran's status, skill level, classification, hourly wage paid (including itemized hourly cash and fringe benefits paid in each pay period), number of hours worked each day, the starting and ending times of work each day, the worker's hourly wage rate, the worker's hourly overtime wage rate, the worker's hourly fringe benefit rates, the name and address of each fringe benefit fund, the plan sponsor of each fringe benefit, if applicable, and the plan administrator of each fringe benefit, if applicable. This record shall be sent to the Illinois Department of Labor no later than the fifteenth (15th) day of each calendar month for the immediately preceding month in which construction on a public works project has occurred. Contractor shall then provide an IDOL certification and case number to the Village. The records must be preserved for five (5) years following completion of the contract. Bidder certifies that Bidder and any subcontractors working on the project are aware that filing false payroll records is a Class A misdemeanor and that the monetary penalties for violations are to be paid pursuant to law by the Bidder, contractor and subcontractor. The Village shall not be liable for any underpayments. If applicable: Since this is a contract for a fixed public works project, as defined in 820 ILCS 130/2, Contractor agrees to post at the job site in an easily accessible place, the prevailing wages for each craft or type of worker or mechanic needed to execute the contract or work to be performed;
4. Bidder certifies that it is in full compliance with the Federal Highway Administrative Rules on Controlled Substances and Alcohol Use and Testing, 49 C.F.R. Parts 40 and 382 and that all employee drivers are currently participating in a drug and alcohol testing program pursuant to the Rules;
5. Bidder further certifies that it is not delinquent in the payment of any tax administered by the Department of Revenue, or that Bidder is contesting its liability for the tax delinquency or the amount of a tax delinquency in accordance with the procedures established by the appropriate Revenue Act. Bidder further certifies that if it owes any tax payment(s) to the Department of Revenue, Bidder has entered into an agreement with the Department of Revenue for the payment of all such taxes that are due, and Bidder is in compliance with the agreement.

Village of Downers Grove – S-008-23 ROW ACCESSIBILITY IMPROVEMENTS

**BIDDER'S CERTIFICATION (page 2 of 3)**

BY: Scott A. Marquart  
Scott A. Marquart, Vice President

3 6 - 2 9 0 2 8 5 0

FEDERAL TAXPAYER IDENTIFICATION NUMBER

or \_\_\_\_\_  
Social Security Number

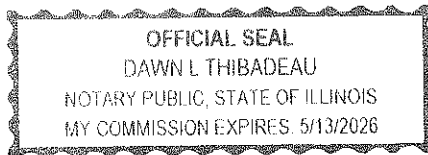

Subscribed and sworn to before me  
this 22nd day of February, 2023.  
D. Thibadeau  
Notary Public

(Fill Out Applicable Paragraph Below)

**(a) Corporation**

The Bidder is a corporation organized and existing under the laws of the State of Delaware, which operates under the Legal name of Alliance Contractors, Inc., and the full names of its Officers are as follows:

President: Michael J. Paulson

Secretary: Helen J. Ruth

Treasurer: \_\_\_\_\_

and it does have a corporate seal. (In the event that this bid is executed by other than the President, attach hereto a certified copy of that section of Corporate By-Laws or other authorization by the Corporation which permits the person to execute the offer for the corporation.)

**Limited Liability Company (LLC)**

The Bidder is a LLC organized and existing under the laws of the State of \_\_\_\_\_, which operates under the legal name of \_\_\_\_\_, and the full names of its managers or members are as follows:

Manager or Member: \_\_\_\_\_

Manager or Member: \_\_\_\_\_

Manager or Member: \_\_\_\_\_

Manager or Member: \_\_\_\_\_

Village of Downers Grove – S-008-23 ROW ACCESSIBILITY IMPROVEMENTS

**BIDDER’S CERTIFICATION (page 3 of 3)**

**(c) Partnership**

The partnership does business under the legal name of: \_\_\_\_\_,  
which name is registered with the office of \_\_\_\_\_ in the State of  
\_\_\_\_\_.

Names and Addresses of All Partners:

\_\_\_\_\_  
\_\_\_\_\_  
\_\_\_\_\_  
\_\_\_\_\_

**(d) Sole Proprietor**

The Bidder is a Sole Proprietor whose full name is: \_\_\_\_\_; and if  
operating under a trade name, said trade name is: \_\_\_\_\_, which name is  
registered with the office of \_\_\_\_\_ in the State of \_\_\_\_\_.

6. Are you willing to comply with the Village’s insurance requirements within 10 days of the award of  
the contract?  YES NO (circle one)

INSURER’S NAME: Cincinnati Insurance Company

AGENT: Arthur J. Gallagher Risk Management Services, Inc.

Street Address: 240 Commerce Dr.

City, State, Zip Code: Crystal Lake, IL 60014

Telephone Number: (815) 459-6300

I/We hereby affirm that the above certifications are true and accurate and that I/we have read and understand  
them.

Print Name of Company: Alliance Contractors, Inc.

Print Name and Title of Authorizing Signature: Scott A. Marquart, Vice President

Signature: 

Date: 2/22/2023

Village of Downers Grove – S-008-23 ROW ACCESSIBILITY IMPROVEMENTS

MUNICIPAL REFERENCE LIST

Municipality: Please see attached. \_\_\_\_\_

Address: \_\_\_\_\_

Contact Name: \_\_\_\_\_ Phone #: \_\_\_\_\_

Name of Project: \_\_\_\_\_

Contract Value: \_\_\_\_\_ Date of Completion: \_\_\_\_\_

Municipality: \_\_\_\_\_

Address: \_\_\_\_\_

Contact Name: \_\_\_\_\_ Phone #: \_\_\_\_\_

Name of Project: \_\_\_\_\_

Contract Value: \_\_\_\_\_ Date of Completion: \_\_\_\_\_

Municipality: \_\_\_\_\_

Address: \_\_\_\_\_

Contact Name: \_\_\_\_\_ Phone #: \_\_\_\_\_

Name of Project: \_\_\_\_\_

Contract Value: \_\_\_\_\_ Date of Completion: \_\_\_\_\_

Municipality: \_\_\_\_\_

Address: \_\_\_\_\_

Contact Name: \_\_\_\_\_ Phone #: \_\_\_\_\_

Name of Project: \_\_\_\_\_

Contract Value: \_\_\_\_\_ Date of Completion: \_\_\_\_\_

Municipality: \_\_\_\_\_

Address: \_\_\_\_\_

Contact Name: \_\_\_\_\_ Phone #: \_\_\_\_\_

Name of Project: \_\_\_\_\_

Contract Value: \_\_\_\_\_ Date of Completion: \_\_\_\_\_

**ALLIANCE CONTRACTORS, INC.**

1166 LAKE AVENUE • WOODSTOCK, ILLINOIS 60098

OFFICE: 815/338-5900 FAX: 815/338-9109

[www.alliancecontractors.com](http://www.alliancecontractors.com)**CONTRACTOR JOB REFERENCES**

Job Name: Downtown Streetscape Improvements

Contact: Village of Huntley

Phone No.: 847-515-5200

Type of Work: Reconstruction of Downtown

Contract Amount \$ 2,928,890.58

---

Job Name: Des Plaines River Road Construction

Contact: City of Des Plaines

Phone No.: 847-391-5300

Type of Work: Reconstruction

Contract Amount \$ 23,668,084.59

---

Job Name: Oak Park Village Hall

Contact: Village of Oak Park

Phone No. 708-383-6400

Type of Work: Parking Lot Rehab

Contract Amount \$ 1,344,461.00

---

Job Name: Pilot Gas Station/Rochelle

Contact: Curran Contracting Company

Phone No. 815-455-5100

Type of Work: Concrete Paving

Contract Amount \$ 1,071,742.60

---

Job Name: DuPage Co. 2020 Bridge Repairs

Contact: DuPage County Div. of Transportation

Phone No.: 630-407-6900

Type of Work: Bridge Repairs

Contract Amount \$ 630-407-6900

---

Job Name: Burlington @ Bolcum/Kane Co.

Contact: Kane Co. Div. of Transportation

Phone No.: 630-584-1170

Type of Work: Roundabout Construction

Contract Amount \$ 782,297.00

**ALLIANCE CONTRACTORS, INC.**

1166 LAKE AVENUE • WOODSTOCK, ILLINOIS 60098

OFFICE: 815/338-5900 FAX: 815/338-9109

[www.alliancecontractors.com](http://www.alliancecontractors.com)

In the past five (5) years, Alliance Contractors, Inc., has completed many projects for the Illinois Department of Transportation, including, but not limited to:

East Avenue/Streamwood  
Contract #61E72  
Contract Amount \$ 459,642.73

Willow Springs Road/Countryside  
Contract #62B63  
Contract Amount \$ 951,393.58

Walnut Lane/Schaumburg  
Contract #61F22  
Contract Amount 2,645,613.00

Rt. 31 Box Culvert/McHenry  
Contract #62G49  
Contract Amount \$ 1,012,036.00

Elgin O'Hare Access Corridor Signs  
Contract #61E69  
Contract Amount \$ 1,004,285.00

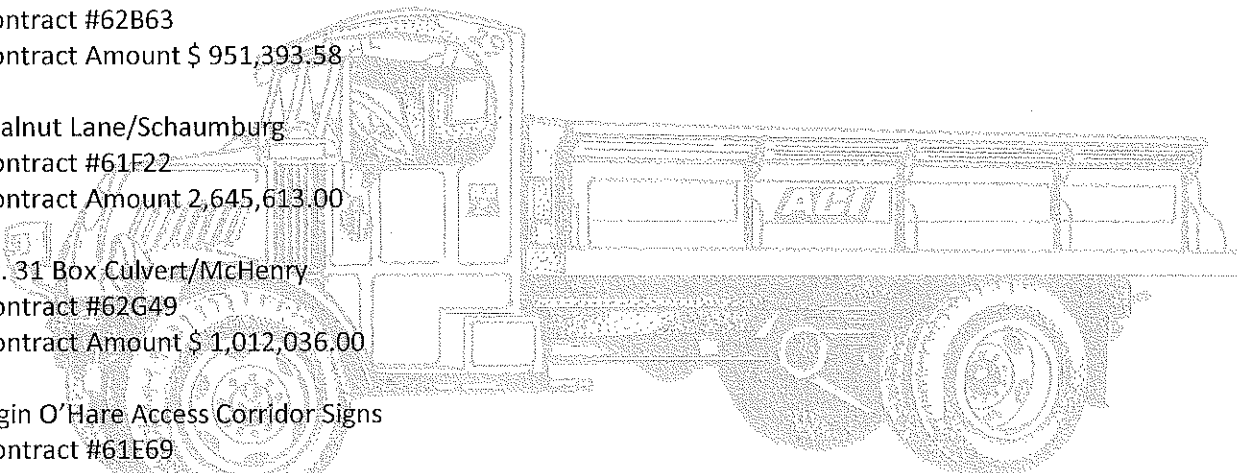

For information regarding performance, contact: Illinois Department of Transportation  
201 West Center Court  
Schaumburg, IL 60196-1096  
Phone: 847-705-4110

Village of Downers Grove – S-008-23 ROW ACCESSIBILITY IMPROVEMENTS

**SUBCONTRACTORS LIST**

The Bidder hereby states the following items of work will not be performed by its organization. (List items to be subcontracted as well as the names, addresses and phone numbers of the subcontractors.)

1) to be determined Type of Work \_\_\_\_\_

Addr: if needed City \_\_\_\_\_ State \_\_\_\_\_ Zip \_\_\_\_\_

2) \_\_\_\_\_ Type of Work \_\_\_\_\_

Addr: \_\_\_\_\_ City \_\_\_\_\_ State \_\_\_\_\_ Zip \_\_\_\_\_

3) \_\_\_\_\_ Type of Work \_\_\_\_\_

Addr: \_\_\_\_\_ City \_\_\_\_\_ State \_\_\_\_\_ Zip \_\_\_\_\_

4) \_\_\_\_\_ Type of Work \_\_\_\_\_

Addr: \_\_\_\_\_ City \_\_\_\_\_ State \_\_\_\_\_ Zip \_\_\_\_\_

5) \_\_\_\_\_ Type of Work \_\_\_\_\_

Addr: \_\_\_\_\_ City \_\_\_\_\_ State \_\_\_\_\_ Zip \_\_\_\_\_

6) \_\_\_\_\_ Type of Work \_\_\_\_\_

Addr: \_\_\_\_\_ City \_\_\_\_\_ State \_\_\_\_\_ Zip \_\_\_\_\_

7) \_\_\_\_\_ Type of Work \_\_\_\_\_

Addr: \_\_\_\_\_ City \_\_\_\_\_ State \_\_\_\_\_ Zip \_\_\_\_\_

8) \_\_\_\_\_ Type of Work \_\_\_\_\_

Addr: \_\_\_\_\_ City \_\_\_\_\_ State \_\_\_\_\_ Zip \_\_\_\_\_

Village of Downers Grove – S-008-23 ROW ACCESSIBILITY IMPROVEMENTS



**VENDOR W-9 REQUEST FORM**

The law requires that we maintain accurate taxpayer identification numbers for all individuals and partnerships to whom we make payments, because we are required to report to the I.R.S all payments of \$600 or more annually. We also follow the I.R.S. recommendation that this information be maintained for all payees including corporations.

Please complete the following substitute W-9 letter to assist us in meeting our I.R.S. reporting requirements. The information below will be used to determine whether we are required to send you a Form 1099. Please respond as soon as possible, as failure to do so will delay our payments.

**BUSINESS (PLEASE PRINT OR TYPE):**

NAME: Alliance Contractors, Inc.

ADDRESS: 1166 Lake Ave.

CITY: Woodstock

STATE: IL

ZIP: 60098

PHONE: (815) 338-5900 FAX: (815) 338-9109

TAX ID #(TIN): 36-2902850

(If you are supplying a social security number, please give your full name)

**REMIT TO ADDRESS (IF DIFFERENT FROM ABOVE):**

NAME: \_\_\_\_\_

ADDRESS: \_\_\_\_\_

CITY: \_\_\_\_\_

STATE: \_\_\_\_\_ ZIP: \_\_\_\_\_

**TYPE OF ENTITY (CIRCLE ONE):**

- Individual
- Sole Proprietor
- Partnership
- Charitable/Nonprofit
- Limited Liability Company – Member-Managed
- Limited Liability Company- Manager-Managed
- Medical
- Corporation**
- Government Agency

SIGNATURE: *[Handwritten Signature]*

DATE: 2/22/2023

Village of Downers Grove – S-008-23 ROW ACCESSIBILITY IMPROVEMENTS

**Apprenticeship and Training Certification**

(Does not apply to federal aid projects. Applicable only to maintenance and construction projects that use Motor Fuel Tax funds or state grant monies.)

Name of Bidder: Alliance Contractors, Inc.

In accordance with the provisions of Section 30-22 (6) of the Illinois Procurement Code, the Bidder certifies that it is a participant, either as an individual or as part of a group program, in the approved apprenticeship and training programs applicable to each type of work or craft that the bidder will perform with its own forces. The Bidder further certifies for work that will be performed by subcontract that each of its subcontractors submitted for approval either (a) is, at the time of such bid, participating in an approved, applicable apprenticeship and training program; or (b) will, prior to commencement of performance of work pursuant to this Contract, begin participation in an approved apprenticeship and training program applicable to the work of the subcontract. The Illinois Department of Labor, at any time before or after award, may require the production of a copy of each applicable Certificate of Registration issued by the United States Department of Labor evidencing such participation by the contractor and any or all of its subcontractors. Applicable apprenticeship and training programs are those that have been approved and registered with the United States Department of Labor. The Bidder shall list in the space below, the official name of the program sponsor holding the Certificate of Registration for all of the types of work or crafts in which the Bidder is a participant and that will be performed with the Bidder's forces. Types of work or craft work that will be subcontracted shall be included and listed as subcontract work. The list shall also indicate any type of work or craft job category that does not have an applicable apprenticeship or training program. **The Bidder is responsible for making a complete report and shall make certain that each type of work or craft job category that will be utilized on the project is accounted for and listed. Return this with the Bid.**

Please see attached.

The requirements of this certification and disclosure are a material part of the Contract, and the Contractor shall require this certification provision to be included in all approved subcontracts. In order to fulfill this requirement, it shall not be necessary that an applicable program sponsor be currently taking or that it will take applications for apprenticeship, training or employment during the performance of the work of this Contract.

Print Name and Title of Authorizing Signature: Scott A. Marquart, Vice President

Signature: 

Date: 2/22/2023

K. Apprenticeship and Training Certification

1. DuPage County Cement Masons Local #803 Joint Apprenticeship Committee
2. Bureau of Apprenticeship and Training Operating Engineers Local #150
3. Chicagoland Laborers Training and Apprenticeship Program
4. Cement Masons Area Joint Apprenticeship and Cement Masons Union Local #502
5. Chicago and Northeast Illinois District Council of Carpenters Apprenticeship and Training Program

Village of Downers Grove – S-008-23 ROW ACCESSIBILITY IMPROVEMENTS

**BUY AMERICA CERTIFICATION**

**Certification requirement for procurement of steel, iron, or manufactured products when Federal funds (Grant Agreement or Cooperative Agreement) are used.**

*Instructions:*

*Bidder to complete the Buy America Certification listed below. Bidder shall certify EITHER COMPLIANCE OR NON-COMPLIANCE (not both). This Certification MUST BE submitted with the Bidder's bid response. Special Note: Make sure you have signed only one of the above statements – either Compliance OR Non-Compliance (not both).*

**Certificate of Compliance**

The bidder or offeror hereby certifies that it **will meet** the requirements of 49 U.S.C. 5323(j)(1), as amended, and the applicable regulations in 49 CFR Part 661.

Signature *Scott A. Magnum*

Company Name Alliance Contractors, Inc.

Title Vice President

Date 2/22/2023

**Certificate of Non-Compliance**

The bidder or offeror hereby certifies that it **cannot comply** with the requirements of 49 U.S.C. 5323(j)(1), as amended, and 49 C.F.R. 661, but it may qualify for an exception pursuant to 49 U.S.C. 5323(j)(2)(A), 5323(j)(2)(B), or 5323(j)(2)(D), and 49 C.F.R. 661.7.

Signature \_\_\_\_\_

Company Name \_\_\_\_\_

Title \_\_\_\_\_

Date \_\_\_\_\_

**AFTER THIS CERTIFICATE HAS BEEN EXECUTED, A BIDDER MAY NOT SEEK A WAIVER.**

Note: The U.S./Canadian Free Trade Agreement does not supersede the Buy America requirement.

## Village of Downers Grove – S-008-23 ROW ACCESSIBILITY IMPROVEMENTS

<b>Suspension or Debarment Certificate</b>
--

Non-Federal entities are prohibited from contracting with or making sub-awards under covered transactions to parties that are suspended or debarred or whose principals are suspended or debarred. Covered transactions include procurement for goods or services equal to or in excess of \$100,000.00. Contractors receiving individual awards for \$100,000.00 or more and all sub-recipients must certify that the organization and its principals are not suspended or debarred.

By submitting this offer and signing this certificate, the Bidder certifies to the best of its knowledge and belief, that the company and its principals:

1. Are not presently debarred, suspended, proposed for debarment, declared ineligible or voluntarily excluded from covered transactions by any federal, state or local governmental entity, department or agency;
2. Have not within a three-year period preceding this Bid been convicted of or had a civil judgment rendered against them for commission of fraud or a criminal offense in connection with obtaining, attempting to obtain, or performing a public (Federal, State or local) transaction or contract under a public transaction, or convicted of or had a civil judgment against them for a violation of Federal or state antitrust statutes or commission of embezzlement, theft, forgery, bribery, falsification or destruction of records, making false statements, or receiving stolen property;
3. Are not presently indicted for or otherwise criminally or civilly charged by a governmental entity (Federal, State, or local) with commission of any of the offenses enumerated in paragraph (2) of this certification; and
4. Have not within a three-year period preceding this application/proposal/contract had one or more public transactions (Federal, State or local) terminated for cause or default.

**If the Bidder is unable to certify to any of the statements in this certification, Bidder shall attach an explanation to this certification.**

Company Name: Alliance Contractors, Inc.

Address: 1166 Lake Ave.

City: Woodstock Zip Code: 60098

Telephone: (815) 338-5900 Fax Number: (815) 338-9109

E-mail Address: estimating@alliancecontractors.com

Authorized Company Signature: 

Print Signature Name: Scott A. Marquart Title of Official: Vice President

Date: 2/22/2023

Village of Downers Grove – S-008-23 ROW ACCESSIBILITY IMPROVEMENTS

**CAMPAIGN DISCLOSURE CERTIFICATE**

Any contractor, proposer, bidder or vendor who responds by submitting a bid or proposal to the Village of Downers Grove shall be required to submit with its bid submission, an executed Campaign Disclosure Certificate.

The Campaign Disclosure Certificate is required pursuant to the Village of Downers Grove Council Policy on Ethical Standards and is applicable to those campaign contributions made to any member of the Village Council.

Said Campaign Disclosure Certificate requires any individual or entity bidding to disclose campaign contributions, as defined in Section 9-1.4 of the Election Code (10 ILCS 5/9-1.4), made to current members of the Village Council within the five (5) year period preceding the date of the bid or proposal release.

By signing the bid documents, contractor/proposer/bidder/vendor agrees to refrain from making any campaign contributions as defined in Section 9-1.4 of the Election Code (10 ILCS 5/9-1.4) to any Village Council member and any challengers seeking to serve as a member of the Downers Grove Village Council.

Under penalty of perjury, I declare:

- Bidder/vendor has not contributed to any elected Village position within the last five (5) years.

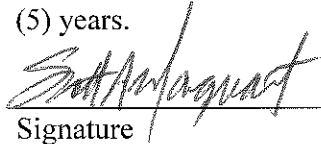
  
Signature

Scott A. Marquart  
Print Name

- Bidder/vendor has contributed a campaign contribution to a current member of the Village Council within the last five (5) years.

Print the following information:

Name of Contributor: \_\_\_\_\_  
(company or individual)

To whom contribution was made: \_\_\_\_\_

Year contribution made: \_\_\_\_\_ Amount: \$ \_\_\_\_\_

\_\_\_\_\_  
Signature

\_\_\_\_\_  
Print Name

## Village of Downers Grove – S-008-23 ROW ACCESSIBILITY IMPROVEMENTS

**BID SUBMITTAL CHECKLIST**

Each Bidder's Bid Package must be submitted with all requisite forms properly completed, and all documentation included. The following list is not all-inclusive, but is designed to facilitate a good, competitive bidding environment.

1.  Instructions to Bidders read and understood. Any questions must be asked according to the instructions.
2.  Cover sheet filled-in
3.  Bid Form copies filled-in. All copies must have original signatures and seals on them.
4.  Bid Bond or cashier's check enclosed with bid package.
5.  Schedule of Prices completed. Check your math!
6.  Bidder Certifications signed and sealed.
7.  Letter from Surety ensuring issuance of Performance and Labor Bonds.
8.  Letter from Insurance Agent or Carrier ensuring issuance of required job coverage.
9.  Municipal Reference List completed.
10.  Vendor request form W-9 completed.
11.  Affidavit (IDOT Form BC-57, or similar).
12.  Bid package properly sealed and labeled before delivery. If sending by mail or messenger, enclose in a second outer envelope or container. Project plan sheets do not have to be included with the bid package.



# Village of Downers Grove

## Contractor Evaluation

---

Contractor: Alliance Contractors, Inc.

Project: 2022 DBD Crosswalk Upgrades S-007

Primary Contact: Brad Spiniolas Phone: 815-338-5900

Time Period: March-May 2022

On Schedule (allowing for uncontrollable circumstances)  Yes  No

Provide details if early or late completion:

Change Orders (attach information if needed): CO to be processed for final quantity balancing. Project under original contract amount.

Difficulties / Positives: Performed satisfactory work, stayed on schedule. Cleanup was consistent throughout project and pedestrian access was maintained. Contractor maintained good traffic control. Contractor has excellent attention to detail, which is required for the type of work.

Interaction with public:

Excellent  Good  Average  Poor

(Attach information on any complaints or compliments)

General Level of Satisfaction with work:

Well Satisfied  Satisfied  Not Satisfied

Reviewers: Katherine Zirbel

Date: 9/14/22