

**VILLAGE OF DOWNERS GROVE**  
**REPORT FOR THE VILLAGE COUNCIL MEETING**  
**APRIL 9, 2013 AGENDA**

<b>SUBJECT:</b>	<b>TYPE:</b>	<b>SUBMITTED BY:</b>
2013 Resurfacing (A) Project (CIP Project ST-004 A), (CIP ST-043)	Resolution Ordinance ✓ Motion Discussion Only	Nan Newlon, P.E. Director of Public Works

**SYNOPSIS**

A motion is requested to award a contract for the 2013 Resurfacing (A) Project to Central Blacktop Company, Inc. of LaGrange, Illinois in the amount of \$1,918,509.63.

**STRATEGIC PLAN ALIGNMENT**

The Goals for 2013 to 2017 identified *Top Quality Infrastructure*.

**FISCAL IMPACT**

The FY13 budget includes \$2,159,000 in the Capital Projects Fund for this project.

**UPDATE & RECOMMENDATION**

This item was discussed at the April 2, 2013 Village Council meeting. Staff recommends approval on the April 9, 2013 Consent Agenda.

**BACKGROUND**

This contract is a component of the 2013 Roadway Maintenance Program (CIP Project ST-004) and includes the reconstruction of one-half block of Chase Road south of Maple (CIP Project ST-043). The scope of this contract includes resurfacing the streets included on the attached list with a new layer of asphalt along with the repair of defective sections of pavement and concrete curb and gutter.

This contract represents a portion of the budgeted roadway maintenance work. Other projects include 2013 Preventive Seal, 2013 Resurfacing (B), 2013 Fall Roadway Patching and proposed hot in-place recycling on Lacey Road and Authority Drive.

A Call for Bids (CFB) was issued and published in accordance with the Village's Purchasing Policy. Four bids were received by the due date of March 18, 2013. A synopsis of the bids is as follows:

<u>Contractor</u>	<u>Base Bid</u>	
<b>Central Blacktop Company</b>	<b>\$1,918,509.63</b>	<b>Low Bid</b>
James D Fiala Paving Co	\$2,039,349.09	
K-Five Construction Corp	\$2,179,055.70	
Geneva Construction Co	\$2,193,734.35	

Central Blacktop Company satisfactorily completed the Village's 2006 Resurfacing Project, 2007 Resurfacing Project and 2012 Resurfacing (A) Project.

**ATTACHMENTS**

Signature Pages

Campaign Disclosure

Contractor Evaluation Form

Capital Project Sheets ST-004, ST-043

List of Streets

2013 ROADWAY MAINTENANCE PROGRAM  
STREETS ESTIMATED TO BE RESURFACED  
STREET RESURFACING (PHASE I)

STREET	FROM	TO
41ST ST	MAIN ST	ELM ST
59TH ST	MAIN ST	FAIRVIEW AVE
61ST ST	W. OF PLYMOUTH ST	DUNHAM RD
67TH PL	DUNHAM RD	POWELL ST
68TH PL	POWELL ST	WEST END
BARRETT ST	67TH ST	CUL DE SAC S. OF 68TH
BELLE AIRE LN	OGDEN AVE	BELLE AIRE SCHOOL
BROOKSIDE LN	VENARD RD	SARATOGA AVE
CHASE AVE	LIMIT S. OF MAPLE AVE	N. OF MAPLE AVE
COMMERCE DR	WARRENVILLE RD	N. CUL DE SAC
DUCHESS CT	BROOKSIDE LN	N. CUL DE SAC
HIGHLAND AVE	OGDEN AVE	HIGHLAND SCHOOL
HILLCREST RD	61ST ST	S. CUL DE SAC
LINDLEY ST	OGDEN AVE	NORTH END
PERSHING AVE	S. OF PRAIRIE AVE	PRAIRIE AVE
POWELL ST	67TH ST	S. OF 68TH PL
RIDGE CT	61ST ST	N. CUL DE SAC
WOODWARD AVE	PRAIRIE AVE	WARREN AVE

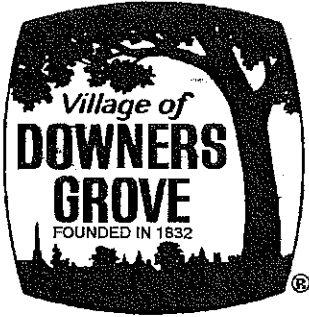

## CALL FOR BIDS – FIXED WORKS PROJECT

- I. Name of Company Bidding: Central Blacktop Co, Inc.
- II. Instructions and Specifications:
- A. Bid No.: ST004A-2013
  - B. For: 2013 RESURFACING (A)
  - C. Bid Opening Date/Time: MARCH 18, 2013 @ 10:00 AM
  - D. Pre-Bid Conference Date/Time: N/A
  - E. Pre-Bid Conference Location: N/A
- III. Required of All Bidders:
- A. Bid Deposit: 5%
  - B. Letter of Capability of Acquiring Performance Bond: NO
  - C. Certificate of Eligibility from IDOT, Prequalified 003 HMA Plant Mix: YES
- IV. Required of Awarded Contractor(s)
- A. Performance Bond or Letter of Credit: YES
  - B. Certificate of Insurance: YES

Legal Advertisement Published: MONDAY, MARCH 4, 2013

This document comprises 106 pages including inserted Check Sheets, Details & Quantity Summary

RETURN ORIGINAL BID IN SEALED ENVELOPE MARKED WITH THE BID NUMBER AS NOTED ABOVE TO:

SCOTT BARR  
STAFF ENGINEER  
VILLAGE OF DOWNERS GROVE  
5101 WALNUT AVENUE  
DOWNERS GROVE, IL 60515  
PHONE: 630/434-5460  
FAX: 630/434-5495  
[www.downers.us](http://www.downers.us)

**CALL FOR BIDS – FIXED WORKS PROJECT**

**Bid No.:** ST004A-2013

The VILLAGE OF DOWNERS GROVE will receive bids Monday thru Friday, 8:00 A.M. to 5:00 P.M. at the Public Works Building, 5101 Walnut Avenue, Downers Grove, IL 60515.

The Village Council reserves the right to accept or reject any and all bids, to waive technicalities and to accept or reject any item of any Bid.

The documents constituting component parts of this Contract are the following:

- I. CALL FOR BIDS
- II. TERMS & CONDITIONS
- III. GENERAL PROVISIONS
- IV. SPECIAL PROVISIONS
- V. BID & CONTRACT FORM

All Bidders MUST submit the entire bid package, with one original Bid Form. Upon formal Award, the successful Bid will automatically convert to a Contract, and the successful Bidder will receive a copy of the executed contract upon formal award of the Bid with the Notice of Award.

**DO NOT DETACH ANY PORTION OF THIS DOCUMENT. INVALIDATION COULD RESULT.**

## **I. CALL FOR BIDS and INSTRUCTIONS TO BIDDERS**

### **1. GENERAL**

- 1.1 Notice is hereby given that Village of Downers Grove will receive sealed bids up to:  
MARCH 18, 2013 @ 10:00 AM
- 1.2 Defined Terms:
  - 1.2.1 Village – the Village of Downers Grove acting through its officers or agents.
  - 1.2.2 Contract Documents – this document plus any drawings issued therewith, any addenda and the Bidder's completed proposal, bonds and all required certifications.
  - 1.2.3 Bid – this document completed by an individual or entity and submitted to the Village.
  - 1.2.4 Bidder – the individual or entity who submits or intends to submit a bid proposal to the Village.
  - 1.2.5 Contractor – the individual or entity whose bid is selected by the Village and who enters into a contract with the Village.
  - 1.2.6 Work – the construction or service defined herein.
  - 1.2.7 Day – unless otherwise stated all references to day “Day” “Days”, “day” or “days” shall refer to calendar days.
  - 1.2.8 Proposal Guaranty – the required bid deposit.
- 1.3 Bids must be received at the Village by the time and date specified. Bids received after the specified time and date will not be accepted and will be returned unopened to the Bidder.
- 1.4 Bids shall be sent to the Village of Downers Grove, ATTN: Scott Barr, in a sealed envelope marked "SEALED BID". The envelope shall be marked with the name of the project, date, and time set for receipt of Bids. The bid package may be submitted any time prior to the time set for receipt of Bids.
- 1.5 All Bids must be submitted on the forms supplied by the Village and signed by a proper official of the company submitting the Bid. Telephone, email and fax Bids will not be accepted.
- 1.6 Under penalty of perjury, the Bidder certifies by submitting this Bid that he has not acted in collusion with any other Bidder or potential Bidder.

### **2. BID PREPARATION**

- 2.1 It is the responsibility of the Bidder to carefully examine the Contract Documents and to be familiar with all of the requirements, stipulations, provisions, and conditions surrounding the proposed Work.

- 2.2 The Bidder shall inspect the site of the proposed Work in detail, investigate and become familiar with all the local conditions affecting the Work and become fully acquainted with the detailed requirements of the Work. Submitting a Bid shall be a conclusive assurance and warranty that the Bidder has made these examinations and that the Bidder understands all requirements for the performance of the Work. If the Bid is accepted, the Bidder will be responsible for all errors in the Bid resulting from his willing or neglectful failure to comply with these instructions. IN NO CASE WILL THE VILLAGE BE RESPONSIBLE FOR ANY COSTS, EXPENSES, LOSSES OR CHANGES IN ANTICIPATED MARGINS OF PROFIT RESULTING FROM THE WILLING OR NEGLECTFUL FAILURE OF THE BIDDER TO MAKE THESE EXAMINATIONS. THE VILLAGE WILL NOT BE RESPONSIBLE FOR ANY COSTS, EXPENSES, LOSSES OR CHANGES IN ANTICIPATED MARGINS OF PROFIT RESULTING FROM THE WILLING OR NEGLECTFUL FAILURE OF THE CONTRACTOR TO PROVIDE THE KNOWLEDGE, EXPERIENCE AND ABILITY TO PERFORM THE WORK REQUIRED BY THIS CONTRACT. No changes in the prices, quantities or contract provisions shall be made to accommodate the inadequacies of the Bidder, which might be discovered subsequent to award of contract. The Bidder shall take no advantage of any error or omission in the Contract Documents nor shall any error or omission in the Contract Documents serve as the basis for an adjustment of the amounts paid to the Bidder.
- 2.3 When the Contract Documents include information pertaining to subsurface explorations, borings, test pits, and other preliminary investigations, such information is included solely for the convenience of the Bidder. *The Village assumes no responsibility whatsoever with respect to the sufficiency of the information, and does not warrant, neither expressly nor by implication, that the conditions indicated represent those existing throughout the Work, or that unanticipated developments may not occur.*
- 2.4 Any information shown in the Contract Documents regarding the locations of underground utility facilities is included solely for the convenience of the Bidder. The Village assumes no responsibility whatsoever with respect to the sufficiency, accuracy or inadequacy of such information. It shall be the Bidder's responsibility to obtain detailed information from the respective utility companies relating to the location of their facilities and the work schedules of the utility companies for removing or adjusting them. Utilities whose facilities may be affected by the work include, but may not be limited to, the following: Nicor, ComEd, SBC, Comcast Cable, Downers Grove Sanitary District, and Village water, storm sewer, and street lighting systems.
- 2.5 No oral or telephone interpretations of specifications shall be binding upon the Village. All requests for interpretations or clarifications shall be made in writing and received by the Village at least five (5) business days prior to the date set for receipt of Bids or the pre-bid conference, if offered. The Village shall make all changes or interpretations of the Contract Documents in a written addendum and shall provide an addendum to any Bidder of record. Any and all changes to the Contract Documents are valid only if they are included by written addendum to all Bidders. Each Bidder must acknowledge receipt of any addenda by indicating same on the Bid Form. Each Bidder, by acknowledging receipt of any addenda, is responsible for the contents of the addenda and any changes to the Bid therein. Failure to acknowledge any addenda may cause the Bid to be rejected. The Village will not assume responsibility for receipt of any addenda. In all cases, it will be the Bidder's responsibility to obtain all addenda issued. Bidders will provide written acknowledgement of receipt of each addendum issued with the bid submission.

- 2.6 An estimate of the quantities of Work to be performed and the materials to be furnished is shown in the Bid Form. It is given as a basis for comparing the properly submitted Bids, and shall be used by the Village in awarding the Contract. The Village does not expressly warrant nor imply that the estimated quantities shown will correspond with those quantities required to perform the Work. No Bidder shall plead misunderstanding or deception because of such an estimate of quantities, or because of the character, location or other conditions pertaining to the Work. Payment shall be based on the actual quantities of work properly performed in accordance with the Contract, at the Contract unit prices specified. The Village reserves the right to increase, decrease or omit entirely, any or all items. No allowance will be made for any change in anticipated profits due to an increase or decrease in the original estimate of quantities.
- 2.7 The Bidder must submit his Bid on the form furnished by the Village. The Bid shall be executed properly, and Bids shall be made for all items indicated in the Bid Form. The Bidder shall indicate, in figures, a unit price or lump sum price for each of the separate items called for in the Bid Form. The Bidder shall show the products of the respective quantities and unit prices in the column provided for that purpose. The gross sum shown in the place indicated in the Bid Form shall be the summation of said products. All writing shall be with ink or typewriter, except the signature of the Bidder, which shall be written with ink.
- 2.8 In case of error in the extension of prices in the Bid, the hourly rate or unit price will govern. In case of discrepancy in the price between the written and numerical amounts, the written amount will govern.
- 2.9 All costs incurred in the preparation, submission, and/or presentation of any Bid including the Bidder's travel or personal expenses shall be the sole responsibility of the Bidder and will not be reimbursed by the Village.
- 2.10 The Bidder hereby affirms and states that the prices quoted herein constitute the total cost to the Village for all work involved in the respective items, as well as the materials to be furnished in accordance with the collective requirements of the Contract Documents. The Bidder also affirms that this cost includes all insurance, bonds, royalties, transportation charges, use of all tools and equipment, superintendence, overhead expense, profits and other work, services and conditions necessarily involved in the work to be done.

2.11 The Bidder shall complete and submit with the Bid an "Affidavit" (IDOT Form BC-57, or similar) listing all uncompleted contracts, including subcontract work; all pending low bids not yet awarded or rejected, and equipment available.

2.12 The Bidder shall complete and submit with the Bid a "Municipal Reference List" indicating other municipalities for which the Bidder has successfully performed similar work.

**3. PRE-BID CONFERENCE**

3.1 A pre-bid conference may be offered to provide additional information, inspection or review of current facilities or equipment, and to provide an open forum for questions from Bidders. This pre-bid conference is not mandatory (unless stated "Required" on the cover of this document), but attendance by Bidders is strongly advised as this will be the last opportunity to ask questions concerning the Bid.

3.2 Questions may be posed in writing to the Village (faxed and emailed questions are acceptable), but must be received by the Village prior to the scheduled time for the pre-bid conference. Questions received will be considered at the conference. An addendum may be issued as a result of the pre-bid conference. Such an addendum is subject to the provisions for issuance of an addendum as set forth in Section 2.5 above.

3.3 No Contract Documents will be issued after the pre-bid conference except to attendees.

**4. BID SUBMISSION**

4.1 An original copy of the sealed bid marked as indicated in Section 1 shall be submitted to the Village.

4.2 A bid deposit will be required, which shall not exceed ten percent (10%) of the estimated cost of the work to be furnished. Such bid deposit shall be in the form of a bid bond, certified check, cash or money order. Checks shall be drawn upon a bank of good standing payable to the order of the Village and said deposit shall be forfeited to the Village in the event the Bidder neglects or refuses to enter into a contract and bond when required, with approved sureties, to execute the Work or furnish the material for the price mentioned in his Bid and according to the plans and specifications in case the contract shall be awarded to him.

4.3 Bids shall be publicly opened at the hour and place indicated above.

**5. BID MODIFICATION OR WITHDRAWAL**

5.1 A Bid that is in the possession of the Village may be altered by a letter bearing the signature or name of the person authorized for submitting a Bid, provided that it is received prior to the time and date set for the bid opening. Telephone, email or verbal alterations of a Bid will not be accepted.

5.2 A Bid that is in the possession of the Village may be withdrawn by the Bidder, up to the time set for the bid opening, by a letter bearing the signature or name of the person authorized for submitting Bids. Bids may not be withdrawn after the bid opening and shall remain valid for a period of ninety (90) days from the date set for the bid opening, unless otherwise specified.

5.3 Any Bidder who does not submit a Bid is requested to return the enclosed Statement of “No Bid” postcard. Bidders not submitting Bids or “No Bid Statement” may otherwise be removed from the Village’s bid mailing list.

**6. BID REJECTION**

6.1 Bids that contain omissions, erasures, alterations, additions not called for, conditional bids or alternate bids not called for, or irregularities of any kind, shall be rejected as informal or insufficient. Bids otherwise acceptable, which are not accompanied by the proper Proposal Guaranty, shall also be rejected as informal or insufficient. The Village reserves the right however, to reject any or all Bids and to waive such technical error as may be deemed best for the interest of the Village.

**7. BIDDER COMPETENCY**

7.1 No Bid will be accepted from or contract awarded to any person, firm or corporation that is in arrears or is in default upon any debt or contract. The Bidder, if requested, must present evidence to the Village of ability and possession of necessary facilities, and financial resources to comply with the terms of the Contract Documents. Evidence must be presented within three (3) business days.

**8. BIDDER DISQUALIFICATION**

8.1 Any one or more of the following causes may be considered as sufficient for the disqualification of a Bidder and the rejection of their Bid.

8.1.1 More than one Bid for the same Work from an individual, firm partnership, or corporation under the same or different names.

8.1.2 Evidence of collusion among Bidders.

8.1.3 Unbalanced Bids in which the prices for some items are substantially out of proportion to the prices for other items.

8.1.4 Failure to submit a unit price for each item of Work listed in the Bid Form.

8.1.5 Lack of competency as revealed by financial statement or experience questionnaire.

8.1.6 Unsatisfactory performance record as shown by past work, judged from the standpoint of workmanship and progress.

8.1.7 Uncompleted work which, in the judgment of the Village, might hinder or prevent the prompt completion of this Work.

8.1.8 Failure to submit a signed Bidder’s Certificate stating the following:

8.1.8.1 That the Bidder is not barred from bidding on this Contract as a result of a violation

of Sections 720 ILCS 5/33-E3 and 720 ILCS 5/33-E4 of the Illinois Compiled Statutes; and

8.1.8.2 The Bidder is not delinquent in the payment of any tax administered by the Illinois Department of Revenue; and

8.1.8.3 The Bidder will maintain the types and levels of insurance required by the terms of this contract; and

8.1.8.4 The Bidder will comply with the Illinois Prevailing Wage Act, 820 ILCS 130/1 *et seq.*

**9. BASIS OF AWARD**

9.1 The Village reserves the exclusive right to accept or reject any and all Bids or to waive sections, technicalities and irregularities, or to accept or reject any Bid or any item of any Bid.

**10. AWARD OF CONTRACT**

10.1 Unless the Village exercises its right to reject all Bids, the Contract will be awarded to that responsible Bidder whose Bid, conforming to the Contract Documents, will be most advantageous to the Village, price and other factors considered. (the credentials, financial information, bonding capacity, insurance protection, qualifications of the labor and management of the firm, past experience and ability to complete the project within time frame required - lowest responsible bidder)

10.2 Unless otherwise specified, if a Contract is not awarded within ninety (90) days after the opening of Bids, a Bidder may file a written request with the Village for the withdrawal of their Bid. The Village will have a maximum of ten (10) days after the receipt of such request to award the Contract or release the Bidder from further obligation by return of the Bidder's bid deposit. Any attempt or actual withdrawal or cancellation of a Bid by the awarded contractor who has been notified by the Village of the acceptance of said Bid shall be considered a breach of contract.

**11. RETURN OF BID DEPOSIT**

11.1 The bid deposit of all except the three (3) lowest responsive bidders on each contract will be returned within fifteen (15) days after the opening of Bids. The remaining bid deposits of each contractor will be returned within fifteen (15) days after the Village Council has awarded the contract and the required appurtenances to the contract have been received.

**12. FAILURE TO ENTER INTO CONTRACT**

12.1 Failure on the part of the successful Bidder to execute a Contract and provide acceptable bonds, as provided herein, within ten (10) days from the date of receipt of the Contract and Notice of Award from the Village, will be considered as just cause for the revocation of the award. The Bidder's bid security shall then be forfeited to the Village, not as a penalty but in payment of liquidated damages sustained as a result of such failure.

12.2 The Bidder shall not be allowed to claim lack of receipt where the Contract and Notice of Award was mailed by U.S. Postal Services certified mail to the business address listed in his Bid. In case the Village does not receive evidence of receipt within ten (10) days of the date of Notice of Award, the

Village may revoke the award. The Bidder shall then forfeit the bid security to the Village, not as a penalty but in payment of liquidated damages sustained as the result of such failure to execute the Contract.

- 12.3 By submitting a Bid, the Bidder understands and agrees that, if his Bid is accepted, and he fails to enter into a contract forthwith, he shall be liable to the Village for any damages the Village may thereby suffer.

**13. SECURITY FOR PERFORMANCE**

- 13.1 The successful Bidder shall, within ten (10) days after acceptance of the Bidder's Bid by the Village, furnish a Performance Bond and a Materials and Labor Payment Bond acceptable to the Village in the full amount of the Bid. Said bonds shall guarantee the Bidder's performance under the Contract Documents and shall guarantee payment of all subcontractors and material suppliers. Any bond shall include a provision as will guarantee faithful performance of the Illinois Prevailing Wage Act, 820 ILCS 130/1 et seq.

**14. TAX EXEMPTION**

- 14.1 The Village is exempt from Illinois sales or use tax for direct purchases of materials and supplies. A copy of the Illinois Sales Tax Exemption Form will be issued upon request. The Village's federal identification number will also be provided to the selected Bidder.

**15. RESERVED RIGHTS**

- 15.1 The Village reserves the right to waive sections, irregularities, technicalities and informalities to this Contract and to accept any Bid and to reject any and all Bids and to disapprove of any and all subcontractors as may be in the best interest of the Village. Time and date requirements for receipt of Bids, however, will not be waived.

**16. CATALOGS AND SHOP DRAWINGS**

- 16.1 Each Bidder shall submit catalogs, descriptive literature, and detailed drawings, where applicable, to fully illustrate and describe the work or material he proposes to furnish.

**17. TRADE NAMES AND SUBSTITUTIONS**

- 17.1 Certain materials and equipment are specified by a manufacturer or trade name to establish standards or quality and performance and not for the purpose of limiting competition. Products of other manufacturers may be substituted, if, in the opinion of the Village, they are equal to those specified in quality, performance, design, and suitability for intended use. If the Bidder proposes to furnish an "equal", the proposed "equal" item must be so indicated in the written Bid. Where two or more items are specified, the selection among those specified is the Bidder's option, or he may submit his Bid on all such items. Detail specification sheets shall be provided by Bidder for all substituted items.

## **II. TERMS AND CONDITIONS**

### **18. VILLAGE ORDINANCES**

18.1 The successful Bidder, now the Contractor, will strictly comply with all ordinances of the Village of Downers Grove and laws of the State of Illinois.

### **19. USE OF VILLAGE'S NAME**

19.1 The Contractor is specifically denied the right of using in any form or medium the name of the Village for public advertising unless the Village grants express permission.

### **20. HOURS OF WORK**

20.1 The Contractor shall do no work between the hours of 7:00 p.m. and 7:00 a.m., nor on Saturdays, Sundays or legal holidays, unless otherwise approved in writing by the Village. However, such work may be performed at any time if necessary, for the proper care and protection of work already performed, or in case of an emergency. All after-hour work is still subject to the permission of the Village.

### **21. PERMITS AND LICENSES**

21.1 The Contractor shall obtain all necessary permits and licenses required to complete the Work. The cost of acquisition of all necessary permits, bonds, insurance and services as specified herein shall be considered INCIDENTAL, and no additional compensation will be allowed the Contractor.

### **22. INSPECTION**

22.1 The Village shall have a right to inspect, by its authorized representative, any material, components or workmanship as herein specified. Materials, components or workmanship that have been rejected by the Village as not in accordance with the terms of the contract specifications shall be replaced by the Contractor at no cost to the Village.

### **23. DELIVERIES**

23.1 All materials shipped to the Village must be shipped F.O.B. designated location, Downers Grove, Illinois.

### **24. SPECIAL HANDLING**

24.1 Prior to delivery of any product that is caustic, corrosive, flammable or dangerous to handle, the Contractor will provide written directions as to methods of handling such products, as well as the antidote or neutralizing material required for its first aid before delivery. Contractor shall also notify the Village and provide material safety data sheets for all substances used in connection with this Contract which are defined as toxic under the Illinois Toxic Substances Disclosure to Employees Act.

### **25. NONDISCRIMINATION**

25.1 Contractor shall, as a party to a public contract:

25.1.1 Refrain from unlawful discrimination in employment and undertake affirmative action to assure equality of employment opportunity and eliminate the effects of past discrimination;

25.1.2 By submission of this Bid, the Contractor certifies that he is an "equal opportunity employer"

as defined by Section 2000(e) of Chapter 21, Title 42, U.S. Code Annotated and Executive Orders #11246 and #11375, which are incorporated herein by reference. The Equal Opportunity clause, Section 6.1 of the Rules and Regulations of the Department of Human Rights of the State of Illinois, is a material part of any contract awarded on the basis of this Bid.

- 25.2 It is unlawful to discriminate on the basis of race, color, sex, national origin, ancestry, age, marital status, physical or mental handicap or unfavorable discharge for military service. Contractor shall comply with standards set forth in Title VII of the Civil Rights Act of 1964, 42 U.S.C. Secs. 2000 et seq., The Human Rights Act of the State of Illinois, 775 ILCS 5/1-101 et. seq, and The Americans With Disabilities Act, 42 U.S.C. Secs. 12101 et. seq.

**26. SEXUAL HARASSMENT POLICY**

26.1 The Contractor, as a party to a public contract, shall have a written sexual harassment policy that:

26.1.1 Notes the illegality of sexual harassment;

26.1.2 Sets forth the State law definition of sexual harassment;

26.1.3 Describes sexual harassment utilizing examples;

26.1.4 Describes the Contractor's internal complaint process including penalties;

26.1.5 Describes the legal recourse, investigative and complaint process available through the Illinois Department of Human Rights and the Human Rights Commission and how to contact these entities; and

26.1.6 Describes the protection against retaliation afforded under the Illinois Human Rights Act.

**27. EQUAL EMPLOYMENT OPPORTUNITY**

27.1 In the event of the Contractor's non-compliance with the provisions of this Equal Employment Opportunity Clause, the Illinois Human Rights Act or the Rules and Regulations of the Illinois Department of Human Rights ("Department"), the Contractor may be declared ineligible for future contracts or subcontracts with the State of Illinois or any of its political subdivisions or municipal corporations, and the contract may be canceled or voided in whole or in part, and such other sanctions or penalties may be imposed or remedies invoked as provided by statute or regulation. During the performance of this Contract, the Contractor agrees as follows:

27.1.1 That it will not discriminate against any employee or applicant for employment because of race, color, religion, sex, marital status, national origin or ancestry, age, physical or mental disability unrelated to ability, military status, order of protection status, sexual orientation, sexual identity, or an unfavorable discharge from military service; and further that it will examine all job classifications to determine if minority persons or women are underutilized and will take appropriate affirmative action to rectify any such underutilization.

27.1.2 That, if it hires additional employees in order to perform this Contract or any portion thereof, it will determine the availability (in accordance with the Department's Rules and Regulations) of

minorities and women in the area(s) from which it may reasonably recruit and it will hire for each job classification for which employees are hired in such a way that minorities and women are not underutilized.

- 27.1.3 That, in all solicitations or advertisements for employees placed by it or on its behalf, it will state that all applicants will be afforded equal opportunity without discrimination because of race, color, religion, sex, marital status, national origin or ancestry, age, physical or mental disability unrelated to ability, military status, order of protection status, sexual orientation, or an unfavorable discharge from military services.
- 27.1.4 That it will send to each labor organization or representative of workers with which it has or is bound by a collective bargaining or other agreement or understanding, a notice advising such labor organization or representative of the Contractor's obligations under the Illinois Human Rights Act and the Department's Rules and Regulations. If any such labor organization or representative fails or refuses to cooperate with the Contractor in its efforts to comply with such Act and Rules and Regulations, the Contractor will promptly so notify the Department and the contracting agency and will recruit employees from other sources when necessary to fulfill its obligations thereunder.
- 27.1.5 That it will submit reports as required by the Department's Rules and Regulations, furnish all relevant information as may from time to time be requested by the Department or the contracting agency, and in all respects comply with the Illinois Human Rights Act and the Department's Rules and Regulations.
- 27.1.6 That it will permit access to all relevant books, records, accounts and work sites by personnel of the contracting agency and the Department for purpose of investigation to ascertain compliance with the Illinois Human Rights Act and the Department's Rules and Regulations.
- 27.1.7 That it will include verbatim or by reference the provisions of this clause in every subcontract it awards under which any portion of the contract obligations are undertaken or assumed, so that such provisions will be binding upon such subcontractor. In the same manner as with other provisions of this Contract, the Contractor will be liable for compliance with applicable provisions of this clause by such subcontractors; and further it will promptly notify the contracting agency and the Department in the event any subcontractor fails or refuses to comply therewith. In addition, the Contractor will not utilize any subcontractor declared by the Illinois Human Rights Commission to be ineligible for contracts or subcontracts with the State of Illinois or any of its political subdivision or municipal corporations.

**28. DRUG FREE WORK PLACE**

28.1 Contractor, as a party to a public contract, certifies and agrees that it will provide a drug free workplace by:

28.1.1 Publishing a statement:

(1) Notifying employees that the unlawful manufacture, distribution, dispensation, possession or use of a controlled substance, including cannabis, is prohibited in the Village's or Contractor's workplace.

(2) Specifying the actions that will be taken against employees for violations of such

prohibition.

(3) Notifying the employee that, as a condition of employment on such contract or grant, the employee will:

- (A) abide by the terms of the statement; and
- (B) notify the employer of any criminal drug statute conviction for a violation occurring in the workplace no later than five (5) days after such conviction.

28.1.2 Establishing a drug free awareness program to inform employees about:

- (1) the dangers of drug abuse in the workplace;
- (2) the Village's or Contractor's policy of maintaining a drug free workplace;
- (3) any available drug counseling, rehabilitation and employee assistance programs;
- (4) the penalties that may be imposed upon employees for drug violations.

28.1.3 Providing a copy of the statement required by subparagraph 1.1 to each employee engaged in the performance of the contract or grant and to post the statement in a prominent place in the workplace.

28.1.4 Notifying the contracting or granting agency within ten (10) days after receiving notice under part (3)(B) of subparagraph 1.1 above from an employee or otherwise receiving actual notice of such conviction.

28.1.5 Imposing a sanction on, or requiring the satisfactory participation in a drug abuse assistance or rehabilitation program by, any employee who is so convicted as required by section 5 of the Drug Free Workplace Act.

28.1.6 Assisting employees in selecting a course of action in the event drug counseling, treatment and rehabilitation is required and indicating that a trained referral team is in place.

28.1.7 Making a good faith effort to continue to maintain a drug free workplace through implementation of the Drug Free Workplace Act.

**29. SUBSTANCE ABUSE PREVENTION ON PUBLIC WORKS PROJECTS ACT**

29.1 In the event this is a public works project as defined under the Prevailing Wage Act, 820 ILCS 130/2, Contractor agrees to comply with the Substance Abuse Prevention on Public Works Projects Act, 820 ILCS 265/1 *et seq.*, and further agrees that all of its subcontractors shall comply with such Act. As required by the Act, Contractor agrees that it will file with the Village prior to commencing work its written substance abuse prevention program and/or that of its subcontractor(s) which meet or exceed the requirements of the Act.

**30. PREVAILING WAGE ACT**

30.1 Contractor agrees to comply with the Illinois Prevailing Wage Act, 820 ILCS 130/1 *et seq.*, for all work completed under this Contract. Contractor agrees to pay the prevailing wage and require that all of its subcontractors pay prevailing wage to any laborers, workers or mechanics who perform work pursuant to this Contract or related subcontract. For applicable rates, go to the State of Illinois – Department of Labor website and use the most current DuPage County rate.

- 30.2 Contractor and each subcontractor shall keep or cause to be kept an accurate record of names, occupations and actual wages paid to each laborer, workman and mechanic employed by the Contractor in connection with the contract. This record shall be open to inspection at all reasonable hours by any representative of the Village or the Illinois Department of Labor and must be preserved for four (4) years following completion of the contract.
- 30.3 Since this is a contract for a public works project, as defined in 820 ILCS 130/2, Contractor agrees to post at the job site in an easily accessible place, the prevailing wages for each craft or type of worker or mechanic needed to execute the contract or work to be performed.
- 30.4 Because this is a public works project as defined under the Prevailing Wage Act, 820 ILCS 130/2, any and all contractors and subcontractors shall submit certified payroll records to the Village no later than the tenth (10<sup>th</sup>) day of each calendar month for the immediately preceding month in which construction on a public works project has occurred. **WITHOUT THIS PAPERWORK, NO INVOICE SHALL BE PAID BY THE VILLAGE.** Contractors and subcontractors must also submit a statement affirming that the records are true and accurate, that the wages paid to each worker are not less than the prevailing rate, and that the contractor and subcontractor are aware that filing false records is a Class A misdemeanor. The records must include the name, address, telephone number, social security number, job classification, hours of work, hourly rate, and start and end time of work each day for every worker employed on the public work. The Village reserves the right to check the pay stubs of the workers on the job. The Village further cautions that payment for any services rendered pursuant to this Contract may be predicated upon receipt of said records.
- 30.5 In the event that this is a construction project where Motor Fuel tax monies or state grant monies are used in the construction, maintenance and extension of municipal streets, traffic control signals, street lighting systems, storm sewers, pedestrian subways or overhead crossings, sidewalks and off-street parking facilities, and the like, the Village will require an Apprenticeship and Training Certification, attached after the Bidder's Certification.
- 30.6 Any bond furnished as security for performance shall include a provision as will guarantee faithful performance of the Illinois Prevailing Wage Act, 820 ILCS 130/1 et seq.

**31. PATRIOT ACT COMPLIANCE**

- 31.1 The Contractor represents and warrants to the Village that neither it nor any of its principals, shareholders, members, partners, or affiliates, as applicable, is a person or entity named as a Specially Designated National and Blocked Person (as defined in Presidential Executive Order 13224) and that it is not acting, directly or indirectly, for or on behalf of a Specially Designated National and Blocked Person. The Contractor further represents and warrants to the Village that the it and its principals, shareholders, members, partners, or affiliates, as applicable are not, directly or indirectly, engaged in, and are not facilitating, the transactions contemplated by this Contract on behalf of any person or entity named as a Specially Designated National and Blocked Person. The Contractor hereby agrees to defend, indemnify and hold harmless the Village, and its elected or appointed officers, employees, agents, representatives, engineers and attorneys, from and against any and all claims, damages, losses, risks, liabilities and expenses (including reasonable attorney's fees and costs) arising from or related to any breach of the foregoing representations and warranties.

**32. INSURANCE REQUIREMENTS**

32.1 Prior to starting the Work, Contractor and any Subcontractors shall procure, maintain and pay for such insurance as will protect against claims for bodily injury or death, or for damage to property, including loss of use, which may arise out of operations by the Contractor or Subcontractor or any Sub-Sub Contractor or by anyone employed by any of them, or by anyone for whose acts any of them may be liable. Such insurance shall not be less than the greater of coverages and limits of liability specified below or any coverages and limits of liability specified in the Contract Documents or coverages and limits required by law unless otherwise agreed to by the Village.

Workers Compensation	\$500,000	Statutory
Employers Liability	\$1,000,000	Each Accident
	\$1,000,000	Disease Policy Limit
	\$1,000,000	Disease Each Employee
Comprehensive General Liability	\$2,000,000	Each Occurrence
	\$2,000,000	Aggregate
		<i>(Applicable on a Per Project Basis)</i>
Commercial Automobile Liability	\$1,000,000	Each Accident
Professional Errors & Omissions (pursuant to section.9 below)	\$2,000,000	Each Claim
	\$2,000,000	Annual Aggregate
Umbrella Liability	\$ 5,000,000	

32.2 Comprehensive General Liability Insurance required under this paragraph shall be written on an occurrence form and shall include coverage for Products/Completed Operations, Personal Injury with Employment Exclusion (if any) deleted, Blanket XCU and Blanket Contractual Liability insurance applicable to defense and indemnity obligations and other contractual indemnity assumed under the Contract Documents. The limit must be on a “Per Project Basis”.

32.3 Commercial Automobile Liability Insurance required under this paragraph shall include coverage for all owned, hired and non-owned automobiles.

32.4 Workers Compensation coverage shall include a waiver of subrogation against the Village.

32.5 Comprehensive General Liability, Employers Liability and Commercial Automobile Liability Insurance may be arranged under single policies for full minimum limits required, **or** by a combination of underlying policies with the balance provided by Umbrella and/or Excess Liability policies.

32.6 Contractor and all Subcontractors shall have their respective Comprehensive General Liability (including products/completed operations coverage), Employers Liability, Commercial Automobile

Liability, and Umbrella/Excess Liability policies endorsed to add the “Village of Downers, its officers, officials, employees and volunteers” as “additional insureds” with respect to liability arising out of operations performed; claims for bodily injury or death brought against the Village by any Contractor or Subcontractor employees, or the employees of Subcontractor’s subcontractors of any tier, however caused, related to the performance of operations under the Contract Documents. Such insurance afforded to the Village shall be endorsed to provide that the insurance provided under each policy shall be *Primary and Non-Contributory*.

- 32.7 Contractor and all Subcontractors shall maintain in effect all insurance coverages required by the Contract Documents at their sole expense and with insurance carriers licensed to do business in the State of Illinois and having a current A. M. Best rating of no less than A- VIII. In the event that the Contractor or any Subcontractor fails to procure or maintain any insurance required by the Contract Documents, the Village may, at its option, purchase such coverage and deduct the cost thereof from any monies due to the Contractor or Subcontractor, or withhold funds in an amount sufficient to protect the Village, or terminate this Contract pursuant to its terms.
- 32.8 All insurance policies shall contain a provision that coverages and limits afforded hereunder shall not be canceled, materially changed, non-renewed or restrictive modifications added, without thirty (30) days prior written notice to the Village. Renewal certificates shall be provided to the Village not less than five (5) days prior to the expiration date of any of the required policies. All Certificates of Insurance shall be in a form acceptable to the Village and shall provide satisfactory evidence of compliance with all insurance requirements. The Village shall not be obligated to review such certificates or other evidence of insurance, or to advise Contractor or Subcontractor of any deficiencies in such documents, and receipt thereof shall not relieve the Contractor or Subcontractor from, nor be deemed a waiver of the right to enforce the terms of the obligations hereunder. The Village shall have the right to examine any policy required and evidenced on the Certificate of Insurance.
- 32.9 If the Work under the Contract Documents includes design, consultation, or any other professional services, Contractor or the Subcontractor shall procure, maintain, and pay for Professional Errors and Omissions insurance with limits of not less than \$2,000,000 per claim and \$2,000,000 annual aggregate. If such insurance is written on a claim made basis, the retrospective date shall be prior to the start of the Work under the Contract Documents. Contractor and all Subcontractors agree to maintain such coverage for three (3) years after final acceptance of the Project by the Village or such longer period as the Contract Documents may require. Renewal policies during this period shall maintain the same retroactive date.
- 32.10 Any deductibles or self-insured retentions shall be the sole responsibility of the Insured. At the option of the Village, either: the insurer shall reduce or eliminate such deductibles or self-insured retentions as respects the Village, its officers, officials, employees and volunteers; or the Contractor shall procure a bond guaranteeing payment of losses and related investigations, claim administration and defense expenses.

### **33. INDEMNITY AND HOLD HARMLESS AGREEMENT**

- 33.1 To the fullest extent permitted by law, the Contractor shall indemnify, keep and save harmless the Village and its agents, officers, and employees, against all injuries, deaths, strikes, losses, damages, claims, suits, liabilities, judgments, costs and expenses, which may arise directly or indirectly from any negligence or from the reckless or willful misconduct of the Contractor, its employees, or its

subcontractors.

- 33.2 The Contractor shall at its own expense, appear, defend and pay all charges of attorneys and all costs and other expenses arising therefrom or incurred in connection therewith, and, if any judgment shall be rendered against the Village in any such action, the Contractor shall, at its own expense, satisfy and discharge the same. This agreement shall not be construed as requiring the Contractor to indemnify the Village for its own negligence. The Contractor shall indemnify, keep and save harmless the Village only where a loss was caused by the negligent, willful or reckless acts or omissions of the Contractor, its employees, or its subcontractors.

**34. SUBLETTING OF CONTRACT**

- 34.1 No contract awarded by the Village shall be assigned or any part subcontracted without the written consent of the Village. In no case shall such consent relieve the Contractor from his obligation or change the terms of this Contract.

All approved subcontracts shall contain language which incorporates the terms and conditions of this Contract.

**35. TERMINATION OF CONTRACT**

- 35.1 The Village reserves the right to terminate the whole or any part of this Contract, upon written notice to the Contractor, for any reason.

- 35.2 The Village further reserves the right to terminate the whole or any part of this Contract, upon ten (10) days' written notice to the Contractor, in the event of default by the Contractor. Default is defined as failure of the Contractor to perform any of the provisions of this Contract or failure to make sufficient progress so as to endanger performance of this Contract in accordance with its terms. In the event that the Contractor fails to cure the default upon notice, and the Village declares default and termination, the Village may procure, upon such terms and in such manner as it may deem appropriate, supplies or services similar to those so terminated. The Village may also contact the issuer of the Performance Bond to complete the Work. The Contractor shall be liable for any excess costs for such similar supplies or services. Any such excess costs incurred by the Village may be set-off against any monies due and owing by the Village to the Contractor.

**36. BILLING AND PAYMENT PROCEDURES**

- 36.1 Payment will be made upon receipt of an invoice referencing Village purchase order number. Once an invoice and receipt of materials or service have been verified, the invoice will be processed for payment in accordance with the Village's payment schedule. The Village will comply with the Local Government Prompt Payment Act, 50 ILCS 505/1 et seq., in that any bill approved for payment must be paid or the payment issued to the Contractor within 60 days of receipt of a proper bill or invoice. If payment is not issued to the Contractor within this 60 day period, an interest penalty of 1.0% of any amount approved and unpaid shall be added for each month or fraction thereof after the end of this 60 day period, until final payment is made.
- 36.2 The Village shall review each bill or invoice in a timely manner after its receipt. If the Village determines that the bill or invoice contains a defect making it unable to process the payment request, the Village shall notify the Contractor as soon as possible after discovering the defect pursuant to rules promulgated under 50 ILCS 505/1 et seq. The notice shall identify the defect and any additional

information necessary to correct it.

36.3 As this Contract is for work defined as a “fixed public work” project under the Illinois Prevailing Wage Act, 820 ILCS 130/2, any contractor or subcontractor is required to submit certified payroll records along with the invoice. No invoice shall be paid without said records.

36.4 Please send all invoices to the attention of: Village of Downers Grove, Accounts Payable, 801 Burlington, Downers Grove, IL 60515.

**37. COMPLIANCE WITH OSHA STANDARDS**

37.1 Equipment supplied to the Village must comply with all requirements and standards as specified by the Occupational Safety and Health Act. All guards and protectors as well as appropriate markings will be in place before delivery. Items not meeting any OSHA specifications will be refused.

**38. CERCLA INDEMNIFICATION**

38.1 The Contractor shall, to the maximum extent permitted by law, indemnify, defend, and hold harmless the Village, its officers, employees, agents, and attorneys from and against any and all liability, including without limitation, costs of response, removal, remediation, investigation, property damage, personal injury, damage to natural resources, health assessments, health settlements, attorneys' fees, and other related transaction costs arising under the Comprehensive Environmental Response, Compensation, and Liability Act (CERCLA) of 1980, 42 U.S.C.A. Sec. 9601, et seq., as amended, and all other applicable statutes, regulations, ordinances, and under common law for any release or threatened release of the waste material collected by the Contractor, both before and after its disposal.

38.2 If the Contractor encounters any waste material governed by the above Act, it shall immediately notify the Village and stop working in the area until the above requirements can be met.

**39. COPYRIGHT or PATENT INFRINGEMENT**

39.1 The Contractor agrees to indemnify, defend, and hold harmless the Village against any suit, claim, or proceeding brought against the Village for alleged use of any equipment, systems, or services provided by the Contractor that constitutes a misuse of any proprietary or trade secret information or an infringement of any patent or copyright.

**40. BUY AMERICA**

40.1 The Contractor agrees to comply with 49 U.S.C.5323(j), the Federal Transportation Administration's (FTA) Buy America regulations at 49 C.F.R. Part 661, and any amendments thereto, and any implementing guidance issued by the FTA, with respect to this Contract, when financed by Federal funds (through a grant agreement or cooperative agreement).

40.2 As a condition of responsiveness, the Contractor agrees to submit with its Bid submission, an executed Buy America Certificate, attached hereto.

**41. CAMPAIGN DISCLOSURE**

41.1 Any contractor, proposer, bidder or vendor who responds by submitting a bid or proposal to the Village of Downers Grove shall be required to submit with its bid submission, an executed Campaign Disclosure Certificate, attached hereto.

- 41.2 The Campaign Disclosure Certificate is required pursuant to the Village of Downers Grove Council Policy on Ethical Standards and is applicable to those campaign contributions made to any member of the Village Council.
- 41.3 Said Campaign Disclosure Certificate requires any individual or entity bidding to disclose campaign contributions, as defined in Section 9-1.4 of the Election Code (10 ILCS 5/9-1.4), made to current members of the Village Council within the five (5) year period preceding the date of the bid or proposal release.
- 41.4 By signing the bid documents, contractor/proposer/bidder/vendor agrees to refrain from making any campaign contributions as defined in Section 9-1.4 of the Election Code (10 ILCS 5/9-1.4) to any Village Council member and any challengers seeking to serve as a member of the Downers Grove Village Council.

**42. GUARANTEE PERIOD**

- 42.1 The Contractor shall provide a guarantee in writing covering a minimum period of one (1) year after approval and acceptance of the Work. The Guarantee shall be in such form as the Village may prescribe, unless otherwise noted in the Specifications, and shall be submitted before receiving final payment. If longer guarantees are required, they will be noted in the Special Provisions for this project.

**43. SUCCESSORS AND ASSIGNS**

- 43.1 The terms of this Contract will be binding upon and inure to the benefit of the parties and their respective successors and assigns; provided, however, that neither party will assign this Contract in whole or in part without the prior written approval of the other. The Contractor will provide a list of key staff, titles, responsibilities, and contact information to include all expected subcontractors.

**44. WAIVER OF BREACH OF CONTRACT**

- 44.1 The waiver by one party of any breach of this Contract or the failure of one party to enforce at any time, or for any period of time, any of the provisions hereof will be limited to the particular instance and will not operate or be deemed to waive any future breaches of this Contract and will not be construed to be a waiver of any provision except for the particular instance.

**45. CHANGE ORDERS**

- 45.1 The contract price is a “not-to-exceed” cost. At any time additional work is necessary or requested, and the not-to-exceed price is increased thereby, all parties must agree to any change, addition or price increase in writing.
- 45.2 Change orders for public works projects which authorize an increase in the contract price that is 50% or more of the original contract price or that authorize or necessitate any increase in the price of a subcontract under the contract that is 50% or more of the original subcontract price must be resubmitted for bidding in the same manner by which the original contract was bid. (50 ILCS 525/1)

**46. SEVERABILITY OF INVALID PROVISIONS**

- 46.1 If any provisions of this Contract are held to contravene or be invalid under the laws of any state, country or jurisdiction, contravention will not invalidate the entire Contract, but it will be construed as if not containing the invalid provision and the rights or obligations of the parties will be construed and

enforced accordingly.

**47. GOVERNING LAW**

47.1 This Contract will be governed by and construed in accordance with the laws of the State of Illinois. Venue is proper only in the County of DuPage for state cases or the Northern District of Illinois for federal cases.

**48. NOTICE**

48.1 Any notice will be in writing and will be deemed to be effectively served when deposited in the mail with sufficient first class postage affixed, and addressed to the party at the party's place of business. Notices shall be addressed to the Village as follows:

**Village Manager  
Village of Downers Grove  
801 Burlington Ave.  
Downers Grove, IL 60515**

And to the Contractor as designated on the Contract Form.

**49. AMENDMENT**

49.1 This Contract will not be subject to amendment unless made in writing and signed by all parties.

**50. COOPERATION WITH FOIA COMPLIANCE**

50.1 Contractor acknowledges that the Freedom of Information Act may apply to public records in possession of the Contractor or a subcontractor. Contractor and all of its subcontractors shall cooperate with the Village in its efforts to comply with the Freedom of Information Act. 5 ILCS 140/1 et.seq.

**51. EMPLOYMENT OF ILLINOIS WORKERS ON PUBLIC WORKS ACT**

51.1 If the work contemplated by this Contract is funded or financed in whole or in part with State Funds or funds administered by the State, Contractor agrees to comply with the terms of the Employment of Illinois Workers on Public Works Act by employing at least 90% Illinois laborers on the project. 30 ILCS 570/1 et seq. Contractor agrees further to require compliance with this Act by all of its subcontractors.

### **III. GENERAL PROVISIONS**

#### **1. STANDARD SPECIFICATIONS**

- 1.1 The following standards shall govern the construction of the proposed improvements:
  - 1.1.1 Standard Specifications for Water and Sewer Main Construction in Illinois, Sixth Edition, 2009 (the Water & Sewer Specs.); and
  - 1.1.2 Standard Specifications for Road and Bridge Construction as adopted by the Illinois Department of Transportation, January 1, 2012; along with Supplemental Specifications and Recurring Special Provisions (collectively the “SSRBC”) as adopted by the Illinois Department of Transportation, January 1, 2013; and
  - 1.1.3 Water Distribution Specifications, Village of Downers Grove, Illinois, revised March, 2006.
- 1.2 These Contract Documents shall take precedence whenever there are conflicts in the wording or statements made by the above specifications and these Contract Documents.
- 1.3 Unless otherwise referenced herein, Division I of the Water and Sewer Specs and Section 102 and Articles 104.02, 104.03, 104.07, 107.02, 107.27, 107.35, 108.10, 108.11, and 108.12 of the SSRBC are hereby suspended.

#### **2. COOPERATION OF CONTRACTOR**

- 2.1 The Contractor will be supplied with a minimum of 2 sets of approved plans and contract assemblies including Special Provisions, one set of which the Contractor shall keep available on the work site at all times. The Contractor shall give the work site constant attention necessary to facilitate the progress thereof, and shall cooperate with the Village in every way possible.
- 2.2 The Contractor shall have on the work site at all times, as the Contractor's agent, a competent English-speaking representative capable of reading and thoroughly understanding the Contract Documents, and thoroughly experienced in the type of work being performed. The representative shall also be capable of receiving instruction from the Village, and shall have full authority to promptly respond to such instruction. He shall be capable of supplying such materials, equipment, tools, labor and incidentals as may be required. The Contractor shall not replace him without prior written notification to the Village.

#### **3. LEGAL REGULATIONS AND RESPONSIBILITY TO THE PUBLIC**

- 3.1 Section 107 of the SSRBC shall govern the Contractor's legal regulations and responsibility to the public, with the following additions:
  - 3.1.1 PROJECT SAFETY. Add the following to Article 107.28:
    - 3.1.1.1 The Contractor shall conduct his work in such a manner as to provide an environment consistent with the safety, health and well being of those engaged in the completion of the Work specified in this Contract.

- 3.1.1.2 The Contractor shall comply with all State and Federal Safety Regulations as outlined in the latest revisions of the Federal Construction Safety Standards (Series 1926) and with applicable provisions and/or regulations of the Occupation Safety and Health Administration (OSHA) and Standards of the Williams-Stelger Occupational Health Safety Act of 1970 (Revised). SPECIAL ATTENTION SHALL BE PAID TO COMPLIANCE WITH OSHA'S SUBPART P – EXCAVATIONS STANDARD.
- 3.1.1.3 The Contractor and Village shall each be responsible for their own respective agents and employees.
- 3.1.2 BACKING PRECAUTIONS. Pursuant to Sections 14-139(b) and 14-171.1 of the Downers Grove Municipal Code, any motor vehicle which has an obstructed view to the rear and is to be operated at any time in reverse gear on the public streets of the Village by the Contractor or any subcontractor shall either be equipped with a reverse signal alarm (backup alarm) audible above and distinguishable from the surrounding noise level, or shall provide an observer to signal that it is safe to back up.
- 3.1.3 OVERWEIGHT, OVERWIDTH AND OVERHEIGHT PERMITS. The Village has and supports an overweight truck enforcement program. Contractors are required to comply with weight requirements and safety requirements as established by Illinois Law or Village Ordinance, for vehicles, vehicle operators and specialty equipment. In some instances, specialty equipment for road repairs or construction projects requires the movement of overweight, overwidth, or overheight loads utilizing a Village roadway. Such movement will require obtaining a permit from the Village Police Department's Traffic Supervisor.
- 3.1.4 BARRICADES AND WARNING SIGNS. The Contractor shall provide the Village with a telephone number of a person or company who is available 24 hours per day, seven days per week, to erect additional barricades or signs. If the Village or its representative deems it necessary for the Public's safety to erect additional barricades or signs during normal working hours, the Contractor will furnish the necessary barricades or signs, and have them in place within 30 minutes. If, after normal working hours, the requested signs are not in place within three hours after the request is made, the Village reserves the right to have the barricades and signs erected. The cost of erecting the barricades and signs shall be deducted by the Village from any payments due the Contractor.

**4. PROSECUTION AND PROGRESS**

4.1 Section 108 of the SSRBC shall govern the prosecution and progress of the work, with the following additions:

4.1.1 The Contractor shall schedule his work such that all improvements shall be substantially complete by **August 2, 2013**. Substantial completion shall mean all work excluding possible full parkway turf restoration. Although actual sod placement may be delayed until more favorable weather conditions, all disturbed turf areas shall be backfilled and dressed and left in a safe and useable condition conducive to possible foot traffic and to the satisfaction of the Village. The completion date will remain binding throughout the duration of the Contract unless revised in writing by the Village.

4.1.2 The total duration of disturbance for work related to means of public egress through the project site or access to private property (e.g. removal and replacement of curb and gutters, sidewalks, driveway entrances, etc.) must not exceed ten (10) calendar days. The Contractor may use high-early strength concrete, meeting all specifications herein, **at his own expense** to help meet this requirement.

4.1.3 The Contractor shall also make special note of the following work schedule requirements:

(A) Unless otherwise allowed by the Village, no contract work on 41<sup>st</sup> Street (area of Highland Ave to Lindley St) can begin until a separate watermain replacement project is completed this spring. It is estimated that the watermain project will be complete by mid June, 2013.

(B) The contractor shall also make special note that no contract work on Highland Ave (north of 41<sup>st</sup> St) or Belle Aire Ln (north of Drove St) or 59<sup>th</sup> St (between Lyman Ave and Grand Ave) can begin until after the school year ends for Downers Grove Grade Schools on or about June 5, 2013.

(C) A separate completion date for Parkway Restoration only has been established by the Village. This date shall be September 17, 2013. This completion date shall pertain only to those disturbed areas, as determined by the Village, where the Contractor is unable to complete sod placement prior to July 1, 2013.

4.1.4 Should the Contractor fail to complete the work on or before the specified completion dates set forth in Sections 4.1.1, 4.1.2 or 4.1.3 or within such extended time as may be allowed, the Contractor shall be liable for liquidated damages in accordance with the applicable sections of Article 108.09 of the SSRBC.

4.1.5 Prior to commencing construction, a meeting will be held with the Contractor and the Village. Any questions concerning procedures, general conditions, special provisions, plans or specific items related to the project shall be answered and clarified. No Pre-Construction meeting shall be scheduled until submittals, performance bonds, and certificates of insurance are delivered to, and approved by, the Village.

- 4.1.6 Weekly progress meetings may be required by the Village. If required, the Contractor shall have a capable person, such as a site superintendent or project manager, attend such meetings and be prepared to report on the prosecution of the Work according to the progress schedule. The Village reserves the right to require adjustments to scheduling of work.

**5. MEASUREMENT AND PAYMENT**

- 5.1 Section 109 of the SSRBC shall govern measurement and payment, with the following additions:

- 5.1.1 Modifies Article 109.07 - Partial payments will be made per Section 36 of Part II of this document (Billing and Payment Procedures.)
- 5.1.2 The Village will require that partial and final affidavits for all labor, materials and equipment used on the Project, be submitted with the partial and final payment requests. Such waivers shall indicate that charges for all labor, materials and equipment used on the project have been paid. Partial waivers from suppliers and subcontractors may be submitted after the first payment to the Contractor, and before the subsequent payment to that which they apply. However, partial waivers from the Contractor must accompany the invoice of the payment to which it applies. All final waivers, from all suppliers and subcontractors **MUST** accompany the Contractor's invoice upon submittal for final payment. A sworn statement by the Contractor shall accompany full waivers. Such requirement for full waivers is solely for the benefit of the Village and shall not be construed to benefit any other person. Partial payment for work done shall in no way imply acceptance of the work to that date.

**IV. SPECIAL PROVISIONS**

The following Special Provisions shall modify, supercede, or supplement the Standard Specifications referred to in Section III - General Provisions.

Where any section, subsection, paragraph, or subparagraph of the Standard Specifications is *supplemented* by any of the following paragraphs, the provisions of such section, subsection, paragraph, or subparagraph shall remain in effect. The Special Provisions shall govern in addition to the particular Standard Specification so supplemented, and not in lieu thereof.

Where any section, subsection, paragraph, or subparagraph of the Standard Specifications is *amended, voided, or superceded* by any of the following paragraphs, any provision of such section, subsection, paragraph, or subparagraph standing unaffected, shall remain in effect. The Special Provisions shall govern in lieu of any particular provision of the Standard Specification so amended, voided, or superceded, and not in addition to the portion changed.

**GENERAL SCOPE OF WORK**

This project consists of pavement removal and replacement, leveling binder, hot-mix asphalt surface course, curb and gutter removal and replacement and all related work. Project covers approximately 4 miles of streets.

INDEX OF LOCAL AGENCY SPECIAL PROVISIONS

TITLE	SP #
GENERAL CONSTRUCTION REQUIREMENTS	1
QUALIFICATIONS OF BIDDER	2
ACCESS AND WATER SHUT OFF NOTIFICATION	3
TREE PROTECTION	4
CLEANING UP	5
EXISTING UTILITIES	6
INCIDENTAL CONSTRUCTION	7
CLASS D PATCHES, 4" & 6"	8
PAVEMENT REMOVAL & HMA REPLACEMENT, 8" SPECIAL	9
COMBINATION CONCRETE CURB AND GUTTER REMOVAL	10
COMBINATION CONCRETE CURB AND GUTTER OF TYPE SPECIFIED	11
POROUS GRANULAR EMBANKMENT, SPECIAL	12
MANHOLES OR INLETS, TO BE ADJUSTED OR RECONSTRUCTED	13
TREE ROOT PRUING	14
PORTLAND CEMENT CONCRETE SIDEWALK	15
AGGREGATE SHOULDERS, TYPE B	16
PARKWAY RESTORATION, SALT TOLERANT, SPECIAL	17
HOT-MIX ASPHALT DRIVEWAY	18
PORTLAND CEMENT CONCRETE DRIVEWAY	19
TEMPORARY RAMP, HMA	20
DECORATIVE PAVER DRIVEWAY OR SIDEWALK REMOVAL & REPLACEMENT	21
CONSTRUCTION STAKING	22
MANHOLE AND INLET CONSTRUCTION	23

STORM SEWER (TYPE, MATERIAL, SIZE SPECIFIED)	24
SELECTED GRANULAR BACKFILL	25
DETECTOR LOOP, TYPE 1	26
EROSION, SEDIMENTATION AND DUST CONTROL	27
TRAFFIC CONTROL, MAINTENANCE OF TRAFFIC, DETOURS	28
HOT-MIX ASPHALT BINDER AND SURFACE COURSE	29
IEPA CLEAN CONSTRUCTION AND DEMOLITION DEBRIS	30

**1 GENERAL CONSTRUCTION REQUIREMENTS**

The following general requirements are intended to govern the overall priority for the performance of the work described in this contract. As general requirements, they are not intended to dictate to the Contractor the precise method by which these tasks shall be performed.

**Special consideration to hours and location of work near schools shall be made to allow for full and safe access during normal student arrival and departure schedules.**

The Contractor shall maintain traffic flow on All Streets during the day in accordance with the applicable special provision. Adequate signing and flagging is of particular importance for safe travel of all residents.

The Contractor shall conduct his operations to interfere as little as possible with Village employees or the public on or near the Work. All construction work specified under this contract shall be so engaged as to not impede normal traffic and pedestrian ways. Any barricading to detour traffic must receive prior written approval from the Engineer.

Unless otherwise allowed by the Village, non-poured and/or non-finished concrete shall not be allowed to extend over a Saturday and Sunday period. All construction work shall be done such that continuous access to schools or businesses is maintained, although it may be restricted to one lane with proper barricading.

All voids and open excavation remaining adjacent to newly constructed curb and gutter, sidewalks, driveways, etc., must be addressed in a timely manner. For that period prior to full parkway restoration or turf placement, the Contractor shall backfill and grade all disturbed areas in the parkway so as to insure the safety of the general public. Parkway shall be left in a safe, clean and usable condition conducive to foot traffic and to the satisfaction of the Village. The Contractor shall also work to keep disturbed areas in the parkway weed free.

All street openings made prior to November 15<sup>th</sup> shall be fully restored according to the applicable special provisions, and the street reopened to regular traffic upon the availability of hot-mix bituminous concrete. The Contractor shall assume the risk of restoration over those reaches of pipe installed but not yet pressure-tested for pipe integrity.

If the project requires the phasing of construction, the contractor is to follow the phasing shown in the plan set. Any variations in the phasing plan shown on the plan set must be approved in writing by the Engineer before construction begins. The contractor will not be allowed to proceed to another phase without the approval of the Engineer. **The contractor will receive no additional compensation for constructing the project in phases.**

No more than three hundred linear feet (300 LF) of pavement may be open-cut and closed to use by the motoring public, and access to **all** individual drives within the current work zone must be restored at the end of each workday, unless a Village-approved phasing plan shows otherwise.

**2 QUALIFICATIONS OF BIDDER**

This space intentionally left blank.

**3 ACCESS AND WATER SHUT OFF NOTIFICATION**

If access to a driveway will be blocked, or water will be turned off, the Contractor shall give that resident or business proper written notification at least 24 hours in advance. The Contractor must provide them the opportunity to remove their cars from the drive or make other arrangements, and prepare for any shutdown of the water system. Samples of written notices shall be submitted to the Engineer for approval.

In addition, the Contractor shall be responsible for notifying the resident or business verbally on the morning of any driveway closure, to ensure awareness of the lack of access.

**Basis of Payment:** This work shall be considered **INCIDENTAL** to the project.

**4 TREE PROTECTION**

Municipal Codes regarding trees, including tree protection requirements for public parkway trees, are located in Chapter 24 of the Downers Grove Municipal Code. Specifically, Municipal Codes 24-7 and 24-8 detail the public parkway tree protection sizes and fines for violations. The Village Forester shall approve all tree protection measures and any deviations. All tree protection measures and any deviations shall be noted in the contract specifications and on approved project plan sheets and permits using the guidelines listed below. Tree protection shall include avoiding damage to the above ground tree branches and trunk, and the below ground root system and surrounding soil. Tree crowns and trunks shall not suffer any branch or bark loss. Roots shall be protected from compaction, storage of materials, severing, regrading of the parkway or excavation unless specifically noted on the project plan sheets.

The Critical Root Zone, or CRZ, is the area immediately surrounding a tree that must be protected from damage. In a municipal parkway setting with utilities and paved or concrete surfaces, the size of the CRZ has been adjusted to form a rectangle around the parkway tree trunk with minimum dimensions listed in the following table. The depth of the CRZ extends to 4 feet below the natural ground surface level.

<u>Parkway Tree diameter at 4.5'</u>	<u>Width street to property (min. curb to sidewalk)</u>	<u>Length along street street(minimum)</u>	<u>Depth</u>
0 – 12.0 inches	10.0 feet	10 feet	4 feet
12.1 – 24.0 inches	10.0 feet	20 feet	4 feet
24.1 or more inches	10.0 feet	30 feet	4 feet

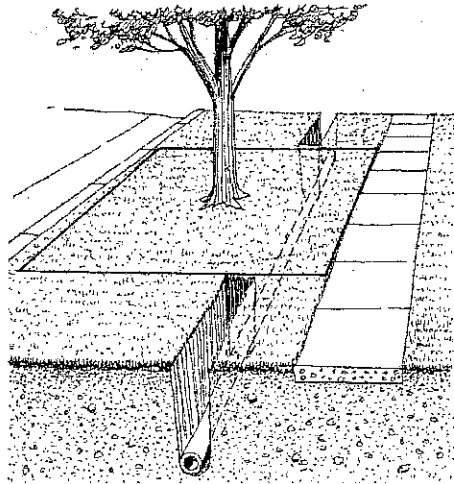

For projects that involve excavations of less than one (1) foot in depth in the parkway or street and are replacing structures in the same location, fencing of the public parkway trees shall not be required. Example projects include, but are not limited to, street pavement resurfacing, curb removal/replacement, driveway removal/replacement, or sidewalk removal/repairs or new sidewalk installations. Contractors shall be mindful of the CRZ dimensions and potential for fines if any parkway trees suffer any unauthorized damage as determined by the Village Forester.

For projects that involve excavations of one (1) or more feet in depth in the parkway or street or both, fencing of the public parkway trees shall be required. Example projects include, but are not limited to, watermain replacements with new roadway keystops and domestic service box installations, sanitary line replacements and new service connections, new or replacement natural gas services, new or replacement phone or fiber optic lines, or new or replacement storm sewers, or projects that widen roads which in turn decreases the parkway soil volume around public parkway trees.

Projects that require fencing (listed above) shall fence the public parkway trees with six (6) foot high chain link construction fence secured to metal posts driven in the ground which are spaced no further than ten (10) feet apart. The dimensions of the fence shall depend on the tree diameter size and shall follow the table listed for the CRZ above, or as large as practical dependent on driveways and other field conditions. The fenced rectangle shall have three (3) sides with the opening facing the adjacent residences for easy access for mowing or tree care. Under no circumstances shall any items be stored within the fence. All fencing shall be maintained daily in an upright good condition. The size and location of all fencing shall be shown on the project plan sheets.

To avoid damage to the CRZ, utilities must be augered underneath the public parkway trees. Excavation pits for augering equipment are to be outside the fenced area and are to be shown on the project plan sheets. Excavation pits for roadway keystops and domestic service boxes are to be as small as practical with excavation occurring in a direction away from the adjacent public parkway tree.

In cases when severing of roots within a portion of the CRZ may be unavoidable (ex. sidewalk installation, curb replacement, water or sanitary service replacement), subject to the approval of the Village Forester, sharp clean cuts shall be made on root ends to promote wound closure and root regeneration. Root pruning and excavation activities shall occur such that the smallest volume of soil and roots is disturbed, and the locations shall be shown on the project plan sheets.

In addition to fines and citations that may be assessed for violations of any Chapter 24 of the Municipal Code (such as not maintaining fencing around the CRZ or unauthorized removal of protected trees), the contractor may be subject to the following provisions:

- issuance of an invoice for the value or partial value of the tree lost due to damage to either the above ground or below ground portions of the parkway tree, or unauthorized tree removal.
- costs of repairs, such as pruning or cabling, or costs for removal of the damaged parkway tree along with the stump if the tree cannot remain in the right-of-way.
- fines of \$500 for the 1<sup>st</sup> offense; \$1,000 for the 2<sup>nd</sup> offense; \$2,500 for the 3<sup>rd</sup> and subsequent offenses.
- each day during which a violation continues shall be construed as a separate and distinct offense.

The value or partial value of the tree lost shall be determined by the Village Forester using the most current edition of the Guide for Plant Appraisal (prepared by the Council of Tree & Landscape Appraisers and the International Society of Arboriculture) and the most current edition of the Species Ratings & Appraisal Factors for Illinois (prepared by the Illinois Arborist Association). The total cost determined for the damage shall be deducted from the payments made to the Contractor for the project. Should the Village hire another Contractor or tree service to complete pruning work, these costs shall also be deducted from the payments made to the Contractor.

Method of Measurement: This work will be measured for payment at the contract unit price per linear foot of fencing as specified. **Only those trees meeting the guidelines and are properly fenced per the specifications shall be counted for payment.** All other work as specified herein shall be considered incidental and will not be paid for separately.

**Basis of Payment**: This work will be paid for at the contract unit price per Foot for:

#### **TREE PROTECTION,**

which price shall be payment in full for the work as specified herein, except tree removal as defined by the standard specifications, which will be paid for separately.

#### **5 CLEANING UP**

The Contractor shall, at all times, keep the premises free from an accumulation of waste material or rubbish caused by his employees or work. At the end of the day, he shall remove all his rubbish from and about the streets and sidewalks. All his tools, form boards, and surplus materials shall be removed and relocated to any temporary on-site storage location assigned by the Village or its Engineer, and shall leave his work "broom clean" or its equivalent, unless more precisely defined. Upon completion of the work called for by the

contract, and upon final inspection and acceptance, the Contractor shall remove any of his remaining rubbish, tools, form boards, and surplus materials completely from the work site.

In case of dispute, the Village may remove the rubbish or other materials and charge the cost to the Contractor.

## **6    EXISTING UTILITIES**

Existing Public Utilities, such as watermains, sewers, gas lines, streetlights, telephone lines, electric power lines, etc., shall be protected against damage during the construction of this project. The Contractor shall contact the Owners of all public utilities and obtain locations of all utilities within the limits of the proposed construction and make arrangements, if necessary, to adjust or move any existing utility at the utility company's expense. Any expense incurred by the contractor in connection with making arrangements shall be borne by the Contractor and considered incidental to the contract. It shall be this Contractor's responsibility to determine the actual location of all such facilities in the field.

The adjustment of all facilities of Nicor, SBC, the Commonwealth Edison Co., DuPage Water Commission, etc. shall be done by the respective utility company, and if known, are indicated on the plans as to be done "By Others". All other utility adjustments to sewer, water, and local facilities shall be performed under this contract, under the supervision of the Owner of the utility, and will be paid for under the respective items in the contract unless otherwise indicated on the plans or directed by the Engineer.

**Any existing facilities, residential or commercial sprinkler systems, etc. disturbed shall be returned to their original condition and any damage to said facilities shall be repaired immediately. The cost of repairs of any damaged utility shall be by agreement between the Contractor and the facility owner or utility company, and at no cost to the Village.**

Whenever the locations of existing utilities are known, the approximate location of said utility is indicated on the plans. This information is given only for the convenience of the Bidder and the Village assumes no responsibility as to accuracy of the information provided. The Contractor shall consider in his bid the location of all permanent and temporary utility appurtenances to their present or relocated positions, whether shown on the plans or not, and no additional compensation will be allowed for delays, inconvenience, or special construction methods required due to the existence of said appurtenances.

Whenever obstructions are encountered during the progress of the work and interfere to such an extent that an alteration in the plan is required, the Engineer shall order a deviation in the plan as required, the Engineer shall order a deviation in the line and/or grade to resolve the conflict, or relocation of the obstruction. The Contractor will be compensated for any additional pipe material, fittings, granular backfill, or structures required at the respective contract prices, and measured as specified in the Contract. No additional compensation will be allowed for delays or inconveniences, additional excavation, or any special construction methods required in prosecuting the work due to the existence of said obstruction.

## **7    INCIDENTAL CONSTRUCTION**

Whenever the performance of work is indicated on the plans and no provisions or specific pay items are included in the contract for payment, the work shall be considered incidental and no additional compensation shall be allowed.

**8 CLASS D PATCHES, 4" & 6"**

Description: This work shall consist of pavement patching by methods and with materials in accordance with Sec. 442 of the Standard Specifications, except as amended herein.

The Contractor shall not use equipment of excessive size or weight that causes damage to existing pavement or appurtenances. Any damage done to the existing pavement or appurtenances that are to remain in place shall be repaired or removed and replaced by the contractor at his/her own expense, as directed by the Engineer.

Pavement patching shall include the saw cutting of existing pavement to a depth not less than four inches (4") or six inches (6") where marked in the field by the Engineer. Pavement patches shall vary in area but minimum width shall be measured at six feet (6'). Pavement patching shall be to a depth not less than four inches (4") or six inches (6"), and shall be a minimum of 4" or 6" below milled surface when Hot-Mix Asphalt Surface Removal is called for.

Where applicable the existing subbase shall be leveled and compacted. Where remaining base is existing HMA, PCC or brick, the bottom of each prepared hole shall be free of all loose material and a bituminous prime shall be applied to the bottom prior to replacement of HMA patches.

The use of surface removal equipment that complies with Art. 440.04 of the SSRBC will be permitted. The edges of the patch shall be smooth and free of loose material to a depth of not less than four inches or six inches.

The hot-mix asphalt material shall conform to the requirements for Hot-Mix Asphalt Binder Course, IL-19.0, N50.

Method of Measurement: Pavement removal and replacement will be measured for payment in place, and the area computed in square yards. Patches determined to be 25 square yards or greater in area shall be classified as Type IV, 4". Patches determined to be less than 25 square yards in area shall be classified as 4" Special.

Basis of Payment: This work shall be paid for at the contract unit price per Square Yard for CLASS D PATCHES, TYPE IV, 4" or CLASS D PATCHES, 4" SPECIAL or CLASS D PATCHES, TYPE IV, 6" or CLASS D PATCHES, 6" SPECIAL which price shall be payment in full for the work as specified herein.

**9 PAVEMENT REMOVAL & HMA REPLACEMENT, 8" SPECIAL**

Description: This work shall consist of pavement patching by methods and with materials in accordance with the applicable parts of Sec. 442 of the Standard Specifications, except as amended herein.

The Contractor shall not use equipment of excessive size or weight that causes damage to existing pavement or appurtenances. Any damage done to the existing pavement or appurtenances that are to remain in place shall be repaired or removed and replaced by the contractor at his/her own expense, as directed by the Engineer.

Pavement patching shall include the full depth saw cutting of the existing pavement as marked by the Engineer. The existing sub-base shall be leveled and compacted. The edges will be smooth and free of loose material to the specified depth of patch.

The hot-mix asphalt material shall conform to the requirements for Hot-Mix Asphalt Binder Course, IL-19.0, N50, and will be placed in compacted lifts not to exceed four inches.

Method of Measurement: Pavement removal and replacement will be measured for payment in place, and the area computed in square yards.

Basis of Payment: This work shall be paid for at the contract unit price per Square Yard for PAVEMENT REMOVAL AND HMA REPLACEMENT, 8" SPECIAL.

## **10 COMBINATION CONCRETE CURB AND GUTTER REMOVAL**

Description: This work shall consist of the removal of existing P.C.C. Curb and Gutter of the type and size at the locations noted in Schedule of Quantities. This work shall be performed in accordance with Section 440 of the Standard Specifications, except as amended herein.

This work shall include a full depth, perpendicular, straight joint sawn at the ends and all edges, including along the edge of pavement, of portions to be removed, unless otherwise directed by the engineer.

At those locations where curb removal operations fall within the Critical Root Zone (CRZ) the Contractor will be required to trench with a "chain" driven trencher immediately back of curb prior to curb removal. This procedure will proceed uninterrupted through the CRZ and insure general tree root pruning. The width of the CRZ shall be determined as noted in the general provision for TREE PROTECTION elsewhere in these documents. If it is determined that proposed removal methods do not cause undo harm to adjacent roots, the Village Forester may waive the need to perform trenching.

During removal operations Contractor shall take special care not to damage or extend sawed joint into adjacent appurtenances such as driveways and sidewalks which are to remain in place. During machine sawing operations Contractor shall also take special care to remove, clean, or otherwise account for any residue / slurry produced by the sawing so material will not be tracked by either vehicular or foot traffic onto adjacent appurtenances which are to remain in place.

Basis of Payment: This work will be paid for at the contract unit price per Linear Foot for COMBINATION CONCRETE CURB AND GUTTER REMOVAL which price shall be payment in full for all work specified herein.

## **11 COMBINATION CONCRETE CURB AND GUTTER OF TYPE SPECIFIED**

Description: This work shall consist of the replacement of existing PCC Curb and Gutter in accordance with the applicable parts of Sec. 606 of the Standard Specifications, except as amended herein.

Replacement of curb and gutter shall include the placement of three-quarter inch (3/4") premolded expansion joint filler along the back of curb, for the full depth of the curb and gutter, where abutting existing concrete.

Transverse expansion joints with  $\frac{3}{4}$ " joint filler shall be constructed at five feet (5') either side of utility structures, and at no more than ninety foot (90') intervals. All expansion joints shall include the placement of two (2) three-quarter inch ( $\frac{3}{4}$ ") dowel bars with pinched stop caps as specified on detail sheet. Two (2) three quarter inch ( $\frac{3}{4}$ ") dowel bars shall also be placed at all construction joints as specified on detail sheet and shall be drilled into existing curb and gutter a minimum of six inches (6").

New curb and gutter shall be backfilled with existing excavated earth.

Transverse contraction joints shall be constructed at no more than fifteen foot (15') intervals.

When new curb and gutter is placed adjacent to concrete pavement or base, it shall be tied along the longitudinal construction joint with No. 6 ( $\frac{3}{4}$ ") bars at 24" centers in accordance with the applicable portions of Article 420.05 of the Standard Specifications.

Placement of curb and gutter as noted on Schedule of Quantities to be reinforced shall also include the placement of two (2) No. 4 ( $\frac{1}{2}$ ") epoxy coated deformed reinforcement bars meeting the applicable portions of Section 508 of the Standard Specifications. Bars shall be placed at one-half depth of the body of the gutter running the entire length of newly placed sections. Curb and gutter placed as described in this paragraph will be paid for as COMBINATION CONCRETE CURB AND GUTTER (TYPE SPECIFIED), REINFORCED.

Including placement of reinforcement bars, placement of curb and gutter as noted on Schedule of Quantities to be reinforced, high early shall be placed with concrete materials meeting the applicable portions of Section 442 of the Standard Specifications. A calcium chloride accelerator will not be permitted. Curb and gutter placed as described in this paragraph shall be paid for as COMBINATION CONCRETE CURB AND GUTTER (TYPE SPECIFIED), REINFORCED, HIGH EARLY.

All voids existing between newly placed curb and gutter and the adjacent roadway pavement shall be filled with Class SI concrete, prior to bituminous surface placement, to a point 1-1/2 inches below finish grade. This work shall be considered incidental.

Placement of curb and gutter shall include the application of membrane curing compound, Type III, in accordance with Articles 1020.13 and 1022.01 of the Standard Specifications unless otherwise directed by the Engineer.

If placement of curb and gutter takes place prior to April 15, or after October 15, the curb and gutter shall be properly cured and that followed by the application of protective coat in accordance with Article 420.18 of the Standard Specifications.

Basis of Payment: This work shall be paid for at the contract unit price per Linear Foot for COMBINATION CONCRETE CURB AND GUTTER (TYPE SPECIFIED) or COMBINATION CONCRETE CURB AND GUTTER (TYPE SPECIFIED), REINFORCED which price shall be payment in full for the work as specified herein.

**12 POROUS GRANULAR EMBANKMENT, SPECIAL**

Description: This work shall consist of removing and disposing of unsuitable sub-grade, furnishing, placing and compacting porous granular material to the lines and grades shown on the plans or as directed by the Engineer in accordance with the applicable portions of Sections 202 and 207 of the Standard Specifications. The material shall be used as a bridging layer over soft, pumpy, loose soil areas and for placement under water. The material shall conform with Article 1003.04 and 1004.05 of the Standard Specifications except the gradation shall be as follows:

1. Crushed Stone, Crushed Blast Furnace Slag and Crushed Concrete

<u>Sieve Size</u>	<u>Percent Passing</u>
*6"	97 $\pm$ 3
*4"	90 $\pm$ 10
2"	45 $\pm$ 25
#200	5 $\pm$ 5

2. Gravel, Crushed Gravel and Pit Run Gravel

<u>Sieve Size</u>	<u>Percent Passing</u>
*6"	97 $\pm$ 3
*4"	90 $\pm$ 10
2"	55 $\pm$ 25
#4	30 $\pm$ 20
#200	5 $\pm$ 5

\*For undercuts less than 18" the percent passing the 6" sieve may be 90 $\pm$ 10 and the 4" sieve requirement eliminated.

The porous granular material shall be placed in one lift when the total thickness to be placed is two (2) feet thick or less or as directed by the Engineer. Rolling each lift of the porous granular material with a vibratory roller meeting the requirements of Article 1101.1 of the Standard Specifications should be sufficient to obtain the desired keying or interlock and necessary compaction. The Engineer shall verify that adequate keying has been obtained.

A three- (3) inch nominal thickness top lift of capping aggregate having a gradation of CA-6 will be required. The use of on-site bituminous grindings resulting from bituminous surface removal, substantially meeting the gradation of CA-6, shall also be permitted. The granular cap shall be compacted to the satisfaction of the Engineer. It shall be the Contractor's responsibility that all proposed bituminous replacement regarding patching and paving operations in these areas will meet the specified performance criteria of their respective pay items.

Construction equipment not necessary for the completion of the replacement material will not be allowed on the undercut areas until completion of the recommended thickness of the porous granular embankment, special.

This work will be measured for payment in accordance with Article 207.04 of the Standard Specifications. When specified on the contract, the theoretical elevation of the bottom of the aggregate subgrade shall be used to determine the upper limit of Porous Granular Embankment, Special. The volume will be computed by the method of average end areas.

Basis of Payment: This work shall be paid for at the contract unit price per Cubic Yard price for: POROUS GRANULAR EMBANKMENT, SPECIAL, which price shall include the capping aggregate, as required.

The Porous Granular Embankment, Special shall be used as field conditions warrant at the time of construction. No adjustment in unit price will be allowed for an increase or decrease in quantities from the estimated quantities shown on the plans.

### **13 MANHOLES OR INLETS, TO BE ADJUSTED OR RECONSTRUCTED**

Description: This item shall be done in accordance with Sec. 602 of the Standard Specifications for Road and Bridge Construction and the following provisions.

All excavation for structure adjustment shall be replaced with Class SI concrete and in accordance with the attached details. For excavation required for reconstructed items, backfill materials shall be mechanically compacted SELECTED GRANULAR BACKFILL placed per the special provision elsewhere in these documents.

Castings shall be set in mortar or bituminous mastic beds. The adjustment of the casting to the required final grade shall be made with precast concrete adjusting rings. Brick, concrete block, or wooden shims will not be permitted.

When adjustments include new frame and grate or new frame and lid, all replacement frames, grates and lids shall be heavy duty. Depending on the type of frame, care shall be taken to properly align the new frame with the curb and gutter, and maintain the proper size opening into the structure.

Although the cost of adjusting structures per this specification will be paid for under this contract, the Contractor shall be aware that many of the structures are not the property of the Village of Downers Grove, and that such work may require inspections and/or permits from other governmental agencies.

For those structures noted on the Schedule of Quantities or as designated by the Engineer as MANHOLE TO BE ADJUSTED, SPECIAL, for that period after Hot-Mix Asphalt Surface Removal operations and prior to adjustment to finished pavement elevation, frames and lids or grates shall be removed from the structure and stored in a safe manner until reused. The resulting void over the structure shall be covered with a steel plate and temporary pavement, or other approved method, capable of carrying the anticipated daily traffic in a safe manner. The Contractor shall also make note of structure location so it may be reestablished after initial bituminous paving operations have been completed.

Basis of Payment: This item shall be paid for at the contract unit price Each for MANHOLE TO BE ADJUSTED or MANHOLE TO BE ADJUSTED, SPECIAL or MANHOLE TO BE ADJUSTED WITH NEW FRAME AND LID (TYPE SPECIFIED) or MANHOLE TO BE RECONSTRUCTED.

This item shall also be paid for at the contract unit price Each for INLET TO BE ADJUSTED or INLET TO BE ADJUSTED WITH NEW FRAME AND GRATE (TYPE SPECIFIED) or INLET TO BE RECONSTRUCTED WITH NEW FRAME AND GRATE (TYPE SPECIFIED) which price shall be payment in full for all labor and materials specified herein including backfill with Selected Granular Backfill.

#### **14 TREE ROOT PRUNING**

Description: All trees, public or private, affected by new sidewalk installation within its root protection zone, shall be root pruned prior to any excavation taking place. Root pruning shall be performed in accordance with the applicable portions of Section 201 of the Standard Specifications as well as the Tree Protection Zone detail of the Plans. Root pruning shall be done only to the depth of the excavation necessary for installing the new walk. Root pruning shall start and proceed uninterrupted for the length of travel through the root protection zone. Root pruning shall be made no more than 10 inches from the tree-side edge of the proposed walk.

Approval by the Village Forester of the equipment to be used for root pruning, as well as the proposed path of the root pruning work, is required prior to the work being performed. The Engineer or his representative shall permit no excavation until written approval is obtained by the Contractor from the Village Forester. Additionally, no materials or equipment may be stored or kept in the Tree Protection Zone. Tree damage, as determined by the Village Forester, shall be assessed to the Contractor using the most recent edition of the Guide for Plant Appraisal, published by the International Society of Arboriculture.

Basis of Payment: This work shall be paid for at the contract unit price per Each for TREE ROOT PRUNING.

#### **15 PORTLAND CEMENT CONCRETE SIDEWALK**

Description: This work shall consist of the removal and replacement of P.C.C. Sidewalk in accordance with the SSRBC, except as amended herein.

Removal of sidewalk shall include the saw cutting of existing concrete as directed by the Engineer. Removal of sidewalks shall also include any necessary pruning and removal of tree roots, bituminous paved sidewalks and/or bituminous overlayment of existing sidewalks, or excavation necessary to place the proposed sidewalk.

Replacement of sidewalk shall be of the width and thickness as noted on the Schedule of Quantities and as directed by the Engineer. Thickness of the proposed sidewalk shall generally be (5") five inch for standard or courtesy walks, (6") six inch for full width across residential drives, and (8") eight inch for full width across commercial drives.

Placement of P.C.C. sidewalk shall include the excavation for and placement of four inches (4") of Type B, CA-6, compacted aggregate base, the (3/4") three-quarter inch scoring of contraction joints (5') five feet on center, the placing of (1/2") one-half inch premolded expansion joints where new concrete abuts existing concrete and/or at (50') fifty feet on center and/or at the end of a pour. This work shall also include the adjustment to proper grade of all water valve or private utility boxes encountered.

Replacement of sidewalk shall include the application of membrane curing compound, Type III, in accordance with Articles 1020.13 and 1022.01 of the Standard Specifications unless otherwise directed by the Engineer.

At those locations where existing street configuration does not contain curb and gutter, it is necessary to end construction of new sidewalk with a minimum of two (2) feet separation from the existing or proposed edge of pavement. At these locations, a HMA transition sidewalk shall be constructed between the concrete sidewalk and the edge of pavement.

Construction of the transition sidewalk shall include excavation as necessary for the full width of the concrete sidewalk, placement and compaction of the four inches (4") of Type B, CA-6 aggregate base, and the placement and compaction of 5 inches (5") of Hot-Mix Asphalt Surface, Mixture D, N50 (IL 9.5) per the applicable portions of Sec. 442 of the Standard Specifications. Asphalt to be placed in compacted layers not to exceed four inches (4").

Hot-Mix Asphalt Binder Course, IL-19.0, N50 may be utilized for the bottom courses, but in all cases the top course shall be a minimum 1 ½ inch lift of the HMA Surface noted above.

For those locations as noted on the Schedule of Quantities or as designated by the Engineer for Detectable Warnings, work shall be completed in accordance with Section 424 of the SSRBC and the Standards included in the details regarding curb ramps with detectable warnings and as amended herein.

Detectable Warnings will NOT include any placement of full depth red dyed concrete or other on-site fabrication such as stamping or molding the fresh concrete with coloring added to the surface of the concrete.

Detectable Warnings shall be limited to inserts meeting the requirements of the ADAAG and subject to approval by the Village.

Color of detectable warnings shall be brick red. The area of red detectable warning shall be protected from overspray during the application of Type III membrane curing compound.

If replacement of sidewalk takes place prior to April 15, or after October 15, all sidewalk shall be properly cured and that followed by the application of protective coat in accordance with Article 420.18 of the Standard Specifications.

Basis of Payment: This work shall be paid for at the contract unit price per square foot for PORTLAND CEMENT CONCRETE SIDEWALK REMOVAL and for PORTLAND CEMENT CONCRETE SIDEWALK, 5" or PORTLAND CEMENT CONCRETE SIDEWALK, 6" or PORTLAND CEMENT CONCRETE SIDEWALK, 8" which price shall be payment in full for the work as specified herein.

Detectable warnings shall be paid for at the contract unit price per Square Foot for DETECTABLE WARNINGS which price shall be in addition to the cost for placement of the 5" sidewalk at the curb ramp.

## **16 AGGREGATE SHOULDERS, TYPE B**

Description: This item shall be done in accordance with Sec. 481 of the SSRBC and shall consist of the construction of approximately two (2) foot wide, four (4) inch deep shoulders or as directed by the Engineer in the area designated by the Engineer.

Unless otherwise directed by the Engineer, existing shoulders with elevations that are too high to accept the proposed aggregate shoulder shall be scraped or excavated as necessary prior to placement of new aggregate. This provision shall also apply to existing shoulders that contain too much vegetation or topsoil. Unnecessary damage or debris outside the designated shoulder area shall be removed and repaired and will not be paid for separately but shall be considered incidental to the cost of Aggregate Shoulders, Type B.

Basis of Payment: This work shall be paid for at the contract unit price per Ton for AGGREGATE SHOULDERS, TYPE B which price shall be payment in full for all labor and materials.

## **17 PARKWAY RESTORATION, SALT TOLERANT, SPECIAL**

Description: This item shall be done in accordance with the applicable portions of Sec. 252 of the Standard Specifications and the following provisions.

As contract work progresses through the Village, parkway restoration work shall commence in a timely manner in areas where permanent placement of new curb and gutter, driveways, sidewalks, etc., has been completed. Under no circumstances shall the Contractor prolong final grading, shaping and sod placement so that the entire project can be permanently restored at the same time.

This work shall consist of the excavation, topsoiling and sodding from a minimum of one and one-half (1-1/2) feet to a maximum of three (3) feet behind or adjacent to all curbs, sidewalks and driveways removed and replaced during the course of construction or as directed by the Engineer. Restoration will also be performed on areas disturbed by storm sewer or culvert construction.

All topsoil to be used for parkway restoration shall be obtained from outside the limits of this improvement, transported to the site and placed at required locations to a minimum depth of 4". All materials shall meet the requirements of Art. 1081.05 of the Standard Specifications. All placement of topsoil shall meet the requirements of Sec. 211 of the Standard Specifications.

All sod shall be salt tolerant meeting the requirements of Art. 1081.03 of the Standard Specifications. All placement of sod shall meet the requirements of Sec. 252 of the Standard Specifications.

Date of Completion: A separate completion date, for Parkway Restoration only has been established by the Village. This date shall be September 17, 2013. This completion date shall pertain only to those disturbed areas, as determined by the Village, where the Contractor is unable to complete sod placement prior to July 1, 2013. Date of completion for Parkway Restoration shall be in accordance with Section 108 of the Standard Specifications.

For that period prior to full parkway restoration, the Contractor shall backfill and grade all disturbed areas so as to insure the safety of the general public. Parkways shall be left in a safe, clean and usable condition conducive to foot traffic and to the satisfaction of the Village. The Contractor shall protect these unfinished areas against erosion and work to keep them weed free.

Basis of Payment: This work shall be paid for at the contract unit price per square yard for PARKWAY RESTORATION, SALT TOLERANT, SPECIAL which price shall be payment in full for any excavation and grading necessary, the furnishing, transporting and placement of all topsoil and sod and the full watering of sod. Unless otherwise directed by the Engineer restoration of disturbed parkways more than three (3) feet behind the back of curb or more than three (3) feet adjacent to newly constructed driveway or sidewalk or more than six (6) feet either side of the newly placed storm sewer or pipe culvert will not be paid for separately but shall be considered incidental to the contract.

Supplemental watering shall be paid for at the contract unit price per Unit for SUPPLEMENTAL WATERING.

## **18 HOT-MIX ASPHALT DRIVEWAY**

Description: This work shall consist of the removal and replacement of asphalt driveways at locations indicated on the plans and/or as required by the Engineer.

The replacement of the driveways shall consist of preparing a subgrade at all required locations, shaping of slopes adjacent to the driveways, the placement and compacting of six inches of CA-6 Aggregate Base, and the placement and compacting of three inches (3") of Hot-Mix Asphalt Surface, Mixture D, N50 (IL 9.5).

At locations noted on Schedule of Quantities, asphalt driveways shall be replaced with the six inches of CA-6 aggregate base along with eight inches (8") of Hot-Mix Asphalt comprised of six inches (6") of Hot-Mix Asphalt Binder, IL-19.0, N50 and finished with a minimum of two inches (2") of Hot-Mix Asphalt Surface, Mixture D, N50 (IL 9.5). Asphalt to be placed in compacted layers not to exceed four inches (4").

This work shall also include the adjustment to proper grade of all water valve or private utility boxes encountered.

The locations at which this work will be measured for payment will consist of only those areas bounded by combination concrete curb and gutter. Those areas where the surface course of the pavement flares into existing driveways beyond the limits of the fully improved areas will not be included for payment.

Basis of Payment: This work will be paid for at the contract unit price per Square Yard for HOT-MIX ASPHALT DRIVEWAY REMOVAL and for HOT-MIX ASPHALT DRIVEWAY PAVEMENT, 3" or for HOT-MIX ASPHALT DRIVEWAY PAVEMENT, 8" which price shall be payment in full for all work as specified herein.

## **19 PORTLAND CEMENT CONCRETE DRIVEWAY**

Description: This work shall consist of the removal and replacement of concrete driveways in accordance with the applicable parts of Sec. 423 of the SSRBC except as amended herein.

This work shall include the placement of ¾" premolded expansion joints where new concrete abuts existing concrete or as directed by the Engineer.

This work shall also include the adjustment to proper grade of all water valve or private utility boxes encountered.

Replacement of the driveways shall include the application of membrane curing compound, Type III, in accordance with Articles 1020.13 and 1022.01 of the SSRBC, unless otherwise directed by the Engineer. If replacement of the driveways takes place prior to April 15, or after October 15, the driveway shall be properly cured and that followed by the application of protective coat in accordance with Article 420.18 of the Standard Specifications.

Basis of Payment: This work will be paid for at the contract unit price per Square Yard for PORTLAND CEMENT CONCRETE DRIVEWAY REMOVAL and for PORTLAND CEMENT CONCRETE DRIVEWAY PAVEMENT, 6" or PORTLAND CEMENT CONCRETE DRIVEWAY PAVEMENT, 8" which price will be payment in full for all work as specified herein.

## **20      TEMPORARY RAMP, HMA**

Description: This work shall consist of construction and maintenance of hot-mix asphalt ramps for temporary access to all abutting side streets and properties per the applicable portions of Article 406.08 of the SSRBC except as amended herein.

At those locations noted on the plans or as directed by the Engineer, the Contractor shall have sufficient bituminous material at the worksite prior to beginning hot-mix asphalt surface removal operations. After hot-mix asphalt surface removal operations and prior to placement of the permanent pavement, temporary ramps shall be constructed to supply access to all abutting streets and properties where traffic is to be maintained. Unless otherwise directed by the Engineer, construction of temporary bituminous ramps for access to abutting private properties will generally be limited to where surface removal operations are over 2 1/2" inches or more in depth.

Basis of Payment: This work will be paid for at the contract unit price per Square Yard for TEMPORARY RAMP, HOT-MIX ASPHALT, which price shall include all costs of furnishing, placing and maintaining the ramps. Removal of the temporary ramps prior to the placement of permanent pavement shall also be included in this item.

## **21      DECORATIVE PAVER DRIVEWAY OR SIDEWALK REMOVAL & REPLACEMENT**

Description: This work shall consist of removal and replacement of existing decorative concrete or brick paver driveways or sidewalks per the applicable portions of Check Sheet LRS 14 of the SSRBC except as amended herein.

At those locations noted on the plans or as directed by the Engineer, the Contractor shall remove existing decorative pavers in such a manner so that no damage occurs to the pavers and with full intent to reuse said paver blocks. Any decorative paver block damaged to an extent that it may not be reused as part of the final pavement, sidewalk or driveway shall be replaced in kind by the Contractor at no additional cost to the Village.

Extent of existing paver removal shall be at the direction of the Engineer. This removal will only be that amount necessary to construct the new curb and gutter or other appurtenance, and replace the decorative pavers to an acceptable grade and appearance.

At those locations where it is determined that an existing bituminous base warrants removal and replacement or repair, this portion of the work would be performed and measured for payment per the special provision for CLASS D PATCHING, of the necessary thickness.

Basis of Payment: This work will be paid for at the contract unit price per Square Yard for DECORATIVE PAVER DRIVEWAY REMOVAL AND REPLACEMENT or DECORATIVE PAVER SIDEWALK REMOVAL AND REPLACEMENT, which price shall be payment in full for all materials and work as specified herein.

## **22 CONSTRUCTION STAKING**

Description: The Contractor shall furnish and place all construction layout stakes for this project. This work shall be conducted by competent personnel with suitable equipment and supervised by a licensed Illinois Land Surveyor. The Contractor shall be responsible for layout for all curb, sidewalk, pipe culvert, driveway and pavement removal and replacement, such that all finished work shall conform substantially to the lines, grades, elevations and dimensions shown on the plans.

The Contractor shall provide adequate control points to construct the individual Project elements, and shall provide the Engineer with adequate control in close proximity to check the compliance of the elements constructed.

Basis of Payment: This work will be paid for at the contract Lump Sum price for CONSTRUCTION STAKING.

## **23 MANHOLE AND INLET CONSTRUCTION**

Description: This work shall consist of the construction of precast concrete drainage structures of the size and type shown on the plans or specified by the Engineer. Included in the contract unit price shall be all excavation, bedding, backfilling and reconnection of all existing inlet and outlet pipe. For all new structures backfill materials shall be mechanically compacted SELECTED GRANULAR BACKFILL placed per the special provision elsewhere in these documents.

All structures in excess of four feet in depth shall be equipped with cast iron steps meeting the standards of ASTM A48. Precast sections shall conform to ASTM C 478 and shall be substantially free from fractures, large or deep cracks and surface roughness. Joints between precast sections shall be designed for rubber gaskets or bituminous mastic material.

Adequate foundation for all structures shall be obtained by removal and replacement of unsuitable materials with well graded granular material; or by tightening with coarse ballast rock, or by such other means as provided for foundation preparation of the connected sewers.

Precast base sections, risers and bottoms, shall be one piece and shall be placed on a well graded granular bedding of not less than two (2) inches in thickness. The bedding course shall be firmly tamped and made smooth and level to assure uniform contact and support of the precast element.

All lift holes shall be completely filled with mortar to ensure water tightness.

Castings shall be set in mortar or bituminous mastic beds. The adjustment of the casting to the required final grade shall be made with precast concrete adjusting rings. Maximum adjustment with rings shall be twelve (12) inches. Brick, concrete block, or wooden shims will not be permitted. Precast concrete adjusting rings shall be set in mortar or bituminous mastic beds.

In pavements, frames and grates or lids shall be heavy duty.

Basis of Payment: This work shall be paid for at the contract unit price Each for INLET, TYPE A, 24" WITH NEW FRAME AND GRATE (TYPE SPECIFIED) or INLET, TYPE B, 36" WITH NEW FRAME AND GRATE (TYPE SPECIFIED) which price shall be payment in full for all labor and materials specified herein including SELECTED GRANULAR BACKFILL.

#### **24 STORM SEWER (TYPE, MATERIAL, SIZE SPECIFIED)**

**Description:** This item shall consist of the construction of Storm Sewer. Storm sewer shall be constructed with new Reinforced Concrete Pipe (RCP), of the IDOT Type appropriate for the depth of cover and the diameter shown with rubber-gasketed joints ASTM C443, or Ductile Iron Pipe with gasket (DIP), AWWA C - 1 Class 52 with SuperCoat interior lining, asphalt exterior coating, and rubber-gasketed joints AWWA C - 111 of the diameter shown, or Polyvinyl Chloride (PVC) Pipe SDR 26 with gasketed, bell and spigot, push on type joints conforming to ASTM D3212 of the diameter shown on the Drawings.

Unless otherwise allowed by the Engineer, the Contractor shall place a well compacted, fine aggregate bedding at least four inches below the pipe and extending the entire width of the trench for the length of the pipe.

The pipe shall be placed so that the entire length of the pipe will have full bearing. No blocking of any kind shall be used to adjust the pipe to grade except when used with concrete encasement.

Laying of sewer pipe shall be accomplished to line and grade in the trench only after it has been de-watered and the foundation and/or bedding has been prepared. Mud, silt, gravel, and other foreign material shall be kept out of the pipe and off the jointing surface.

All pipe laid shall be retained in position so as to maintain alignment and joint closure until sufficient backfill has been completed to adequately hold the pipe in place. All pipes shall be laid to conform to the prescribed line and grade shown on the Plans.

The sewer pipe, unless otherwise approved by the Engineer, shall be laid up grade from point of connection on the existing sewer or from a designated starting point. The sewer pipe shall be installed with the bell end forward or upgrade, unless approved otherwise. When pipe laying is not in progress, the forward end of the pipe shall be kept tightly closed with an approved temporary plug.

The following specific items shall be considered incidental to storm sewer pipe construction and their costs shall be merged into the contract unit price per Linear Foot of the storm sewer pipe.

1. Removal of all surplus trench excavation from site.
2. Excavation for and placement of bedding material.
3. Support of trenches, including any necessary bracing or shoring.
4. De-watering of trench or excavation.
5. Placement and compaction of backfill by vibratory plate or other approved mechanical device.
6. Coring into existing drainage structures where connections are called for on the plans.

Basis of Payment: This work shall be paid for at the contract unit price per Linear Foot for STORM SEWER (TYPE, MATERIAL, SIZE SPECIFIED) which price shall include all labor, material, and equipment necessary for excavation, bedding, installing, jointing, and backfilling the sewers and all incidental work herein specified.

## **25 SELECTED GRANULAR BACKFILL**

Description: All trenches and excavations beneath pavements and driveways, as shown on the plans or as directed by the Engineer in the field, will require SELECTED GRANULAR BACKFILL.

Such material shall meet the applicable requirements of Section 1004 of the SSRBC, except as amended herein. Except for the capping aggregate, the material will meet the gradation for CA-7, CA-11 or the gradation commonly known as ¾" chip.

**Backfill shall be placed in maximum 12" lifts and compacted by vibrating plate or other mechanical compacting device in a manner consistent with the Standard Specifications, to ensure that no future settlement occurs.**

All backfilling shall be done in accordance with Section 20-2.21 of the Standard Specifications for Water and Sewer Main Construction in Illinois. Specifically, all trenches and excavations other than those shown on the plans or designated by the Engineer to receive SELECTED GRANULAR BACKFILL shall be backfilled by any acceptable method which will not dislodge or damage the pipe, or cause bridging action in the trench. After SELECTED GRANULAR BACKFILL is placed as haunching to one-half pipe outside diameter, spoil material may be used as backfill in turf areas.

**Payment shall be made only for the placement of SELECTED GRANULAR BACKFILL as Haunching, Initial Backfill, and Final Backfill along storm sewer pipe, as defined in the Standard Specifications for Water and Sewer Main Construction in Illinois.**

**All backfilling, including granular bedding and backfill of approved excavated material, and placement and compaction of SELECTED GRANULAR BACKFILL around new or reconstructed storm sewer or structures shall be considered incidental to the contract.**

When Select Backfill is placed to the existing surface elevation and used as a temporary driving or walking surface, this item shall also include the maintenance of trench surface in a safe and usable condition, satisfactory to the engineer, until the permanent proposed pavement or walkway is completed.

This item also includes the disposal of the surplus excavated material that is replaced by selected granular backfill. Any material meeting the aforementioned gradation that has been excavated from the trenches may be used for backfilling the trenches. However, no compensation will be allowed as selected granular backfill for the portion of the trench backfilled with excavated material.

Basis of Payment: All work to backfill around new and reconstructed storm sewer or structures with SELECTED GRANULAR BACKFILL shall be considered Incidental to each respective pay item and will not be paid for separately.

**26     DETECTOR LOOP, TYPE 1**

Description: This work shall consist of the replacement of detector loops at the intersection of 59<sup>th</sup> Street and Fairview Ave. The placement of the detector loop shall take place after the level binder course but prior to the surface course of asphalt being placed. All detector loop work shall be in accordance with Section 886 of the Standard Specifications.

The Contractor shall supply cut sheets to the Engineer for the wire and sealer to be used. The Contractor shall also notify the Engineer at the time the work is taking place to allow for inspection by Village personnel.

Upon completion of the work, the Contractor shall supply written confirmation that all new and existing detector loops are in working order.

Basis of Payment: This work will be paid for at the contract unit price per Linear Foot of DETECTOR LOOP, TYPE 1, measured along the sawed slot in the pavement, which price shall include furnishing, installing and testing of the detector loop. This price shall also include splicing of new detector loop to existing shielded cable in the adjacent handhole. All work to replace or construct any necessary dive holes shall be considered incidental and will not be paid for separately.

**27     EROSION, SEDIMENTATION AND DUST CONTROL**

Description: Throughout each and every phase of the project, all downstream ditches and storm sewers shall be protected from the run-off of roadway surfaces, excavations, and other construction activities generating the movement of dirt, mud, dust and debris. This work shall consist of constructing temporary erosion and sedimentation control systems as shown on the plans or as directed by the Engineer. The work shall be placed by methods and with materials in accordance with Sections 280, 1080 and 1081 of the SSRBC, except as amended herein.

All roadway surfaces shall be kept free of dirt, mud, dust and debris of any kind at all times through all phases of the project. All downstream ditches shall be protected from erosion and sedimentation by the installation of silt fence ditch checks; straw bales shall not be used. Piles of excavated material and/or trench backfill material, allowed to be in place in excess of three days, shall be protected against erosion and sedimentation runoff by use of silt fence. Storm sewer inlet structures or manholes shall be protected by temporary placement of geotextile fabric, filter baskets, or solid lids, as authorized in the field by the Engineer.

Dirt, mud, dust and debris of any kind shall be removed from the roadway surface to the satisfaction of the Engineer by any one or combination of the following: approved mechanical sweeping equipment, manual labor, or other approved techniques.

Erosion and sedimentation control measures as indicated in the Erosion Control Plan, or as directed by the Engineer shall be installed on the project site prior to beginning any construction activities which will potentially create conditions subject to erosion. Erosion control devices shall be in place and approved by the Engineer as to proper placement and installation prior to beginning other work. Erosion control protection for Contractor equipment storage sites, plant sites, and other sites shall be installed by the Contractor and approved by the Engineer prior to beginning construction activities at each site.

On those streets designated for Aggregate Base Repair and Preparation of Aggregate Base, dust control shall include the application of water to the existing aggregate base, as conditions warrant, by water truck or other approved method. Unless otherwise directed by the Engineer, during dry periods between rains, a minimum of two applications per day will be necessary.

**Silt Fence** Placement, maintenance, and removal of silt fence at areas designated by the Engineer. The work shall be placed by methods and materials in accordance with Sections 280 and 1080 of the SSRBC, except as amended herein.

#### **DEFICIENCY CHARGE:**

The Village reserves the right to apply deficiency deductions per the applicable portions of Article 105.03 of the SSRBC.

**Basis of Payment:** This work shall be paid for at the contract Lump Sum price for: EROSION, SEDIMENTATION AND DUST CONTROL except for INLET FILTERS.

This work shall also be paid for at the contract unit price per Each for INLET FILTERS or INLET FILTERS CLEANING

#### **28 TRAFFIC CONTROL, MAINTENANCE OF TRAFFIC, DETOURS**

**Description:** This item shall include the furnishing, installing, maintaining, relocating and removing of all traffic control devices and personnel used for the purpose of regulating, warning, or directing traffic during the construction of this project. Placement and maintenance of all traffic control devices shall be in accordance with the applicable parts of Article 107.14 and Section 701 of the Standard Specifications and included Highway Standards. All traffic control devices used on this project shall conform to the Standard Specifications for Traffic Control Devices and the Illinois Manual on Uniform Traffic Control Devices.

No waiving of these requirements will be allowed without prior written approval of the Engineer.

The Contractor shall protect all workers engaged in the project, and shall provide for safe and convenient public travel by providing adequate traffic control under all circumstances. Such circumstances may include, but not be limited to work performed along the route under construction, road closures for construction operations of any type, or when any section of the road is opened to traffic prior to completion of all work. The Contractor shall ensure that work zone in question is properly signed, barricaded and otherwise marked.

The contractor will be responsible for the proper location, installation, and arrangement of all traffic control devices during the period of construction. All open excavations shall be protected by Type I barricades equipped with working bi-directional flashing lights at each end of the excavation, as well as at 50-foot intervals between ends for excavations greater than 50 feet in length and weighted down by **one sandbag per each barricade**. All street closures shall be protected by Type III barricades equipped with working bi-directional flashing lights and weighted down by **eight sandbags per each barricade**.

The Contractor shall plan his work so that there will be no open excavations during non-working hours and that all barricades not necessary have been removed from the pavement during non-working hours.

In the event that one direction of vehicular travel must be closed, the Contractor has the option of setting up a detour route or using flaggers (minimum of two) to direct traffic around the work area. The Engineer shall approve proper signing and barricading of the detour route and lane closures, and shall issue written authorization prior to closure.

In the event that both directions of vehicular travel must be closed, the Contractor shall set up a detour route to direct traffic around the work area. The Engineer shall approve proper signing and barricading of the detour route and shall issue written authorization prior to closure.

The Contractor shall maintain his operations in a manner such that traffic flow shall not be substantially impeded during the construction of the proposed improvements. Where traffic must cross open trenches during a given work day, the Contractor shall provide steel plates at street intersections and driveways. Prior to the end of a given work day, the pavement surface shall be temporarily restored.

No open excavation may be left overnight or on the weekend without the express written permission of the Engineer.

No street closure shall be permitted without the express written permission of the Engineer. No street closure may exceed 800 linear feet, nor be in effect from Friday night at 4:30PM to Monday morning at 9:00AM. Where it is necessary to establish a temporary detour, all the requirements of the Standard Specifications and MUTCD shall be met.

As the condition and location of the work changes, the Contractor shall maintain all traffic control devices and personnel engaged in traffic control, in a manner that will accommodate the changing particulars of the work at any given time. Advance warnings, detour and directional information and other controls or directions necessary for safe passage of traffic around the work site shall be reviewed and changed, if necessary, to meet the needs of the situation. Signage erected, but not necessary or proper for the situation ahead shall be covered or taken down. Barricading and signage shall be monitored by the Contractor on a daily basis to ensure that it meets the requirements for work zone safety for the conditions of the particular work being performed.

The Contractor shall provide a name and phone number of a responsible party capable of providing emergency service, 24 hours per day, for the duration of the Project.

**DEFICIENCY CHARGE:**

The primary concern of the Village is to maintain a safe travel way for the public and a safe environment for the work in the construction zone. The Contractor is expected to comply with the Standard Specifications, contract plans, the Special Provisions and directions from the Engineer concerning traffic control and protection. The Contractor shall provide a telephone number where a responsible individual can be contacted on a 24-hour-a-day basis to receive notification of any deficiencies regarding traffic control and protection. The Contractor shall immediately respond correcting traffic control deficiencies by dispatching workers, materials and equipment to correct such deficiencies.

Failure to comply with directions from the Engineer for corrections or modifications to the traffic control and protection will result in a deduction of either \$1,000 or 0.05 percent of the awarded contract value, whichever is greater, in accordance with Article 105.03. This charge is separate from the cost of any corrective work ordered. The Contractor shall not be relieved of any contractual responsibilities by the Village's actions.

Basis of Payment: This work shall be paid for at the contract Lump Sum price for TRAFFIC CONTROL, MAINTENANCE OF TRAFFIC, DETOURS which price shall be payment in full for the installation and maintenance of proper traffic control to protect the work and public for the duration of the Project.

**29 HOT-MIX ASPHALT BINDER AND SURFACE COURSE**

This item shall be done in accordance with all applicable parts of Sections 406 and 1030 of the SSRBC, the included BDE Specifications, and included mix table.

<b>HOT-MIX ASPHALT MIXTURE REQUIREMENTS</b>	
<b>MIXTURE TYPE</b>	<b>AIR VOIDS</b>
<b>PAVEMENT RESURFACING</b>	
Leveling Binder (Machine Method), N50 (IL-9.5 mm)	4% @ 50 Gyr.
Hot-Mix Asphalt Surface Course, Mix "D", N50 (IL-9.5 mm)	4% @ 50 Gyr.
<b>PATCHING</b>	
Class D Patches (HMA Binder IL-19 mm)	4% @ 50 Gyr.
Pavement Removal & HMA Replacement (HMA Binder IL-19 mm)	4% @ 50 Gyr.
<b>DRIVEWAYS</b>	
Hot-Mix Asphalt Surface Course, Mix "D", N50 (IL-9.5 mm)	4% @ 50 Gyr.
Hot-Mix Asphalt Base Course (HMA Binder IL-19 mm)	4% @ 50 Gyr.

The unit weight used to calculate all Hot-Mix Asphalt Surface Mixture Quantities is 112 Lbs/SqYd/In.

The "AC Type" for polymerized HMA mixes shall be SBS/SBR PG 70-22 and for non-polymerized HMA the "AC Type" shall be "PG 64-22" unless modified by district one special provisions.  
For "Percent of RAP" see district one special provisions.

All preparation of the existing base shall be considered incidental to its respective pay item. This shall include but not be limited to cleaning cracks with an air compressor or other approved method prior to placement of mixture for cracks, joints and flangeways.

Basis of Payment: Prime Coat shall be paid for at the contract unit price per Gallon for BITUMINOUS MATERIALS (PRIME COAT), and at the contract unit price per Ton for AGGREGATE (PRIME COAT).

The HMA surfacing shall be paid for at the contract unit price per Ton for MIXTURE FOR CRACKS, JOINTS AND FLANGEWAYS, and LEVELING BINDER (MACHINE METHOD), N50, and HOT-MIX ASPHALT SURFACE COURSE, MIX D, N50.

**30**      **IEPA CLEAN CONSTRUCTION AND DEMOLITION DEBRIS**

**Description:** If construction activities will result in removal and disposal of excavation spoils, per Illinois Public Act 96-1416 and the Illinois Environmental Protection Agency, soil sampling and analysis, along with certification from a licensed professional engineer (PE) or licensed professional geologist (PG) that the soil is uncontaminated, will be required prior to clean construction and demolition debris (CCDD) facility acceptance. However, if the subject property has never been used for industrial or commercial purposes, and is not adjacent to Potentially Impacted Properties (PIPs), then the site owner or operator may certify that the soil is uncontaminated by use of IEPA form LPC-662.

To facilitate meeting the above requirements for this project, the Village will supply a signed Source Site Certification by Owner or Operator form LPC-662, or a signed LPC-663 form if warranted by a PIP investigation. Neither the form LPC-662, nor the LPC-663 shall be considered a guarantee that excavated material shall meet the requirements of Illinois Public Act 96-1416, and the Contractor shall be responsible for satisfactory removal and disposal of all material as specified herein. No additional environmental testing of the existing on-site material may be performed without prior written permission from the Engineer. In the event that Contractor performs any additional testing without the written permission of the Engineer, Contractor will be required to properly and legally dispose of all material from the project site, regardless of its suitability for disposal in a CCDD facility, at his own expense, without any additional payment for testing, hauling and disposal as specified below.

The Village anticipates that one or more of the following CCDD facilities will accept material from this project:

- Reliable Lyons CCDD, 4226 Lawndale Ave, Lyons, IL 60534
- Hanson Material Service, 125 N Independence Blvd Romeoville, IL 60446
- Bluff City Materials, 1245 Gifford Rd, Elgin, IL 60120
- EF Heil, 12152 South Naper Plainfield Road, Plainfield, IL 60585

Contractor shall consult with these facilities prior to submitting a bid for this project. Contractor shall base his bid on hauling all CCDD generated by this project to these facilities. No additional compensation will be allowed for hauling to any other facilities, for any reason, unless none of the above listed facilities will accept the material. If an alternate facility was approved by the Village prior to bid submittal, and that facility will no longer accept the material, the facilities listed above shall be used by the Contractor at no additional cost to the Village, unless none of the above facilities will accept the material. In the case where neither any of the above listed facilities, nor a pre-approved alternate facility, will accept the material, the Village and Contractor shall attempt to locate an alternate facility, unless the material is classified as unsuitable for disposal in a CCDD facility, in which case it shall be hauled to a landfill and paid for as specified below. Should the Contractor wish to haul material to an alternate facility, the name, location and contact information for the proposed facility shall be submitted to the Village for evaluation, a minimum of five (5) calendar days prior to submission of a bid. Any costs associated with additional sampling, analysis, and/or reporting to meet the acceptance requirements of the alternate facility shall be borne by the bidding Contractor and included within the Contractor's bid. By submitting a bid, Contractor agrees that at least one (1) of the above listed facilities, or an alternate facility approved by the Village in writing prior to the submission of the bid, will accept the material and shall be used for disposal of all CCDD from this project, unless otherwise determined to be non-hazardous special waste as specified below. In the event that the Contractor needs to alter the CCDD facility used for placement of excavated material, the Contractor shall notify the Engineer no later than three (3) days in advance of the planned alteration. In no event shall material be hauled to an alternate facility without the written permission of the Engineer.

**Construction Requirements:** The Contractor shall be responsible for satisfactory removal and disposal of all waste material, asphalt, concrete, stone, dirt, and debris generated or discovered in the course of the work. Removal and disposal of excavation items being disposed of at a clean construction and demolition debris (CCDD) facility shall meet the requirements of Public Act 96-1416. This work shall be incidental and shall not be paid for separately, with the exception of the **ADDITIONAL HAULING SURCHARGE, NON-HAZARDOUS SPECIAL WASTE** as specified below.

The temporary storing of excavated materials within the public right-of-way or project limits shall not be allowed unless approved by the Engineer. It shall be the Contractor's responsibility to find an approved dumpsite for debris and any excavated materials. The Village will not provide one.

The Contractor shall employ a licensed testing firm, as approved by Engineer, to screen each truck-load of material on-site, using a PID or FID field screen or other acceptable method. The PID shall be calibrated on a daily basis. The Contractor or Contractor's testing consultant shall enter all truck-loads leaving the site into an on-site screening log including, but not limited to, project name, date, time, weather conditions, name of screener, hauling company, truck number, screening method, background PID reading, calibrated PID reading, truck/bucket PID reading, and description of materials screened. Each day prior to the first truck leaving the site, Engineer and Contractor's testing consultant shall agree on the allowable PID reading in accordance with the receiving CCDD facility procedures (typically 0.0 or daily background levels). The receiving CCDD facility may be consulted daily, or periodically, as needed to verify that the appropriate value is being used. If said screen indicates levels that will be unacceptable for disposal at the CCDD facility, the material shall be quarantined on-site for further evaluation. If material is rejected at the CCDD facility, it shall be returned to the project site and quarantined for further evaluation. No additional compensation shall be allowed for returning a rejected load back to the project site. Should it be determined by the Village or Village's agent that the material is not suitable for disposal in a CCDD facility, the Contractor shall be responsible for properly disposing of the material at an acceptable landfill, and providing the Village with all of the proper paperwork to document the material disposal with the IEPA. This work shall be paid for as specified below. If a truck-load is rejected by a CCDD facility after leaving the project site, and said truck-load is not identified in the on-site screening log, the Contractor shall still be required to properly dispose of the material and provide the Village with the necessary documentation, but shall not be additionally compensated as specified below.

All additional work to satisfy these requirements shall be the responsibility of the Contractor. All costs associated with meeting these requirements shall be paid for as specified herein. These costs shall include but are not limited to all required testing, lab analysis, and certification by a licensed professional engineer (PE) or licensed professional geologist (PG), if required, in addition to the cost of additional hauling, dump fees, etc. Payment for this work shall be in addition to payment for EARTH EXCAVATION per the contract unit price. No adjustment to the contract unit price will be allowed due to changes to quantities based on actual field conditions.

**Basis of Payment:** This work shall be paid for at the contract unit price per **LOAD** for:

**ADDITIONAL HAULING SURCHARGE, NON-HAZARDOUS SPECIAL WASTE,**

which price shall be payment in full for the work as specified herein.

CHECK SHEET  
FOR  
RECURRING SPECIAL PROVISIONS

Adopted January 1, 2013

The following RECURRING SPECIAL PROVISIONS indicated by an "X" are applicable to this contract and are included by reference:

<u>CHECK SHEET #</u>	<u>RECURRING SPECIAL PROVISIONS</u>	<u>PAGE NO.</u>
1	<input type="checkbox"/> Additional State Requirements For Federal-Aid Construction Contracts (Eff. 2-1-69) (Rev. 1-1-10) .....	35
2	<input type="checkbox"/> Subletting of Contracts (Federal-Aid Contracts) (Eff. 1-1-88) (Rev. 5-1-93) .....	38
3	<input type="checkbox"/> EEO (Eff. 7-21-78) (Rev. 11-18-80) .....	39
4	<input type="checkbox"/> Specific Equal Employment Opportunity Responsibilities Non Federal-Aid Contracts (Eff. 3-20-69) (Rev. 1-1-94) .....	49
5	<input type="checkbox"/> Required Provisions - State Contracts (Eff. 4-1-65) (Rev. 1-1-13) .....	54
6	<input type="checkbox"/> Asbestos Bearing Pad Removal (Eff. 11-1-03) .....	59
7	<input type="checkbox"/> Asbestos Waterproofing Membrane and Hot-Mix Asphalt Surface Removal (Eff. 6-1-89) (Rev. 1-1-09) .....	60
8	<input type="checkbox"/> Haul Road Stream Crossings, Other Temporary Stream Crossings, and In-Stream Work Pads (Eff. 1-2-92) (Rev. 1-1-98) .....	61
9	<input type="checkbox"/> Construction Layout Stakes Except for Bridges (Eff. 1-1-99) (Rev. 1-1-07) .....	62
10	<input type="checkbox"/> Construction Layout Stakes (Eff. 5-1-93) (Rev. 1-1-07) .....	65
11	<input type="checkbox"/> Use of Geotextile Fabric for Railroad Crossing (Eff. 1-1-95) (Rev. 1-1-07) .....	68
12	<input type="checkbox"/> Subsealing of Concrete Pavements (Eff. 11-1-84) (Rev. 1-1-07) .....	70
13	<input type="checkbox"/> Hot-Mix Asphalt Surface Correction (Eff. 11-1-87) (Rev. 1-1-09) .....	74
14	<input type="checkbox"/> Pavement and Shoulder Resurfacing (Eff. 2-1-00) (Rev. 1-1-09) .....	76
15	<input type="checkbox"/> PCC Partial Depth Hot-Mix Asphalt Patching (Eff. 1-1-98) (Rev. 1-1-07) .....	77
16	<input type="checkbox"/> Patching with Hot-Mix Asphalt Overlay Removal (Eff. 10-1-95) (Rev. 1-1-07) .....	79
17	<input type="checkbox"/> Polymer Concrete (Eff. 8-1-95) (Rev. 1-1-08) .....	80
18	<input type="checkbox"/> PVC Pipeliner (Eff. 4-1-04) (Rev. 1-1-07) .....	82
19	<input type="checkbox"/> Pipe Underdrains (Eff. 9-9-87) (Rev. 1-1-07) .....	83
20	<input type="checkbox"/> Guardrail and Barrier Wall Delineation (Eff. 12-15-93) (Rev. 1-1-12) .....	84
21	<input type="checkbox"/> Bicycle Racks (Eff. 4-1-94) (Rev. 1-1-12) .....	88
22	<input type="checkbox"/> Temporary Modular Glare Screen System (Eff. 1-1-00) (Rev. 1-1-07) .....	90
23	<input type="checkbox"/> Temporary Portable Bridge Traffic Signals (Eff. 8-1-03) (Rev. 1-1-07) .....	92
24	<input type="checkbox"/> Work Zone Public Information Signs (Eff. 9-1-02) (Rev. 1-1-07) .....	94
25	<input type="checkbox"/> Night Time Inspection of Roadway Lighting (Eff. 5-1-96) .....	95
26	<input type="checkbox"/> English Substitution of Metric Bolts (Eff. 7-1-96) .....	96
27	<input type="checkbox"/> English Substitution of Metric Reinforcement Bars (Eff. 4-1-96) (Rev. 1-1-03) .....	97
28	<input type="checkbox"/> Calcium Chloride Accelerator for Portland Cement Concrete (Eff. 1-1-13) .....	98
29	<input type="checkbox"/> Portland Cement Concrete Inlay or Overlay for Pavements (Eff. 11-1-08) (Rev. 1-1-13) .....	99
30	<input type="checkbox"/> Quality Control of Concrete Mixtures at the Plant (Eff. 8-1-00) (Rev. 1-1-11) .....	102
31	<input checked="" type="checkbox"/> Quality Control/Quality Assurance of Concrete Mixtures (Eff. 4-1-92) (Rev. 1-1-11) .....	110
32	<input type="checkbox"/> Digital Terrain Modeling for Earthwork Calculations (Eff. 4-1-07).....	122

CHECK SHEET  
FOR  
LOCAL ROADS AND STREETS RECURRING SPECIAL PROVISIONS

Adopted January 1, 2013

The following LOCAL ROADS AND STREETS RECURRING SPECIAL PROVISIONS indicated by an "X" are applicable to this contract and are included by reference:

LOCAL ROADS AND STREETS RECURRING SPECIAL PROVISIONS

<u>CHECK SHEET #</u>		<u>PAGE NO.</u>
LRS 1	<b>Reserved</b> .....	125
LRS 2	<input type="checkbox"/> Furnished Excavation (Eff. 1-1-99) (Rev. 1-1-07).....	126
LRS 3	<input type="checkbox"/> Work Zone Traffic Control (Eff. 1-1-99) (Rev. 1-1-10).....	127
LRS 4	<input type="checkbox"/> Flaggers in Work Zones (Eff. 1-1-99) (Rev. 1-1-07).....	128
LRS 5	<input type="checkbox"/> Contract Claims (Eff. 1-1-02) (Rev. 1-1-07).....	129
LRS 6	<input type="checkbox"/> Bidding Requirements and Conditions for Contract Proposals (Eff. 1-1-02) (Rev. 1-1-13).....	130
LRS 7	<input type="checkbox"/> Bidding Requirements and Conditions for Material Proposals (Eff. 1-1-02) (Rev. 1-1-13).....	136
LRS 8	<b>Reserved</b> .....	142
LRS 9	<input type="checkbox"/> Bituminous Surface Treatments (Eff. 1-1-99) (Rev. 1-1-11).....	143
LRS 10	<b>Reserved</b> .....	144
LRS 11	<input type="checkbox"/> Employment Practices (Eff. 1-1-99).....	145
LRS 12	<input type="checkbox"/> Wages of Employees on Public Works (Eff. 1-1-99) (Rev. 1-1-13).....	147
LRS 13	<input type="checkbox"/> Selection of Labor (Eff. 1-1-99)(Rev. 1-1-12).....	149
LRS 14	<input checked="" type="checkbox"/> Paving Brick and Concrete Paver Pavements and Sidewalks (Eff. 1-1-04) (Rev. 1-1-09).....	150
LRS 15	<input type="checkbox"/> Partial Payments (Eff. 1-1-07).....	153
LRS 16	<input type="checkbox"/> Protests on Local Lettings (Eff. 1-1-07) (Rev. 1-1-13).....	154
LRS 17	<input type="checkbox"/> Substance Abuse Prevention Program (Eff. 1-1-08)(Rev. 1-8-08).....	155
LRS 18	<input type="checkbox"/> Multigrade Cold Mix Asphalt (Eff. 1-1-07) (Rev. 1-1-13).....	156

BDE SPECIAL PROVISIONS  
For the April 26 and June 14, 2013 Lettings

The following special provisions indicated by an "x" are applicable to this contract and will be included by the Project Development and Implementation Section of the BD&E. An \* indicates a new or revised special provision for the letting.

<u>File Name</u>	<u>#</u>	<u>Special Provision Title</u>	<u>Effective</u>	<u>Revised</u>
80240	1	Above Grade Inlet Protection	July 1, 2009	Jan. 1, 2012
80099	2	Accessible Pedestrian Signals (APS)	April 1, 2003	Jan. 1, 2007
80274	3	Aggregate Subgrade Improvement	April 1, 2012	Jan. 1, 2013
80309	4	Anchor Bolts	Jan. 1, 2013	
80192	5	Automated Flagger Assistance Device	Jan. 1, 2008	
80173	6	Bituminous Materials Cost Adjustments	Nov. 2, 2006	Jan. 1, 2012
80241	7	Bridge Demolition Debris	July 1, 2009	
80276	8	Bridge Relief Joint Sealer	Jan. 1, 2012	Aug. 1, 2012
5026I	9	Building Removal-Case I (Non-Friable and Friable Asbestos)	Sept. 1, 1990	April 1, 2010
5048I	10	Building Removal-Case II (Non-Friable Asbestos)	Sept. 1, 1990	April 1, 2010
5049I	11	Building Removal-Case III (Friable Asbestos)	Sept. 1, 1990	April 1, 2010
5053I	12	Building Removal-Case IV (No Asbestos)	Sept. 1, 1990	April 1, 2010
<del>80292</del>	<del>13</del>	<del>Coarse Aggregate in Bridge Approach Slabs/Footings</del>	<del>April 1, 2012</del>	<del>April 1, 2013</del>
80310	14	Coated Galvanized Steel Conduit	Jan. 1, 2013	
80198	15	Completion Date (via calendar days)	April 1, 2008	
80199	16	Completion Date (via calendar days) Plus Working Days	April 1, 2008	
80293	17	Concrete Box Culverts with Skews > 30 Degrees and Design Fills ≤ 5 Feet	April 1, 2012	
80294	18	Concrete Box Culverts with Skews ≤ 30 Degrees Regardless of Design Fill and Skews > 30 Degrees with Design Fills > 5 Feet	April 1, 2012	
80311	19	Concrete End Sections for Pipe Culverts	Jan. 1, 2013	
80277	20	Concrete Mix Design – Department Provided	Jan. 1, 2012	
80261	21	Construction Air Quality – Diesel Retrofit	June 1, 2010	
80029	22	Disadvantaged Business Enterprise Participation	Sept. 1, 2000	Aug. 2, 2011
80312	23	Drain Pipe, Tile, Drainage Mat, and Wall Drain	Jan. 1, 2013	
80313	24	Fabric Bearing Pads	Jan. 1, 2013	
80265	25	Friction Aggregate	Jan. 1, 2011	
80229	26	Fuel Cost Adjustment	April 1, 2009	July 1, 2009
80303	27	Granular Materials	Nov. 1, 2012	
80304	28	Grooving for Recessed Pavement Markings	Nov. 1, 2012	Jan. 1, 2013
80169	29	High Tension Cable Median Barrier	Jan. 1, 2007	Jan. 1, 2013
80246	30	Hot-Mix Asphalt – Density Testing of Longitudinal Joints	Jan. 1, 2010	April 1, 2012
80315	31	Insertion Lining of Culverts	Jan. 1, 2013	
<del>80320</del>	<del>32</del>	<del>Liquidated Damages</del>	<del>April 1, 2013</del>	
80045	33	Material Transfer Device	June 15, 1999	Jan. 1, 2009
80297	34	Modified Urethane Pavement Marking	April 1, 2012	
80165	35	Moisture Cured Urethane Paint System	Nov. 1, 2006	Jan. 1, 2010
80253	36	Movable Traffic Barrier	Jan. 1, 2010	Jan. 1, 2013
80231	37	Pavement Marking Removal	April 1, 2009	
80298	38	Pavement Marking Tape Type IV	April 1, 2012	
80254	39	Pavement Patching	Jan. 1, 2010	
<del>80321</del>	<del>40</del>	<del>Pavement Removal</del>	<del>April 1, 2013</del>	
80022	41	Payments to Subcontractors	June 1, 2000	Jan. 1, 2006
80316	42	Placing and Consolidating Concrete	Jan. 1, 2013	
80278	43	Planting Woody Plants	Jan. 1, 2012	Aug. 1, 2012
80305	44	Polyurea Pavement Markings	Nov. 1, 2012	Jan. 1, 2013
80279	45	Portland Cement Concrete	Jan. 1, 2012	Jan. 1, 2013

<u>File Name</u>	<u>#</u>	<u>Special Provision Title</u>	<u>Effective</u>	<u>Revised</u>
80300	46	Preformed Plastic Pavement Marking Type D - Inlaid	April 1, 2012	
80218	47	Preventive Maintenance – Bituminous Surface Treatment	Jan. 1, 2009	April 1, 2012
80219	48	Preventive Maintenance – Cape Seal	Jan. 1, 2009	April 1, 2012
80220	49	Preventive Maintenance – Micro-Surfacing	Jan. 1, 2009	April 1, 2012
80221	50	Preventive Maintenance – Slurry Seal	Jan. 1, 2009	April 1, 2012
80281	51	Quality Control/Quality Assurance of Concrete Mixtures	Jan. 1, 2012	Jan. 1, 2013
34261	52	Railroad Protective Liability Insurance	Dec. 1, 1986	Jan. 1, 2006
80157	53	Railroad Protective Liability Insurance (5 and 10)	Jan. 1, 2006	
80306	54	Reclaimed Asphalt Pavement (RAP) and Reclaimed Asphalt Shingles (RAS)	Nov. 1, 2012	Jan. 1, 2013
80283	55	Removal and Disposal of Regulated Substances	Jan. 1, 2012	Nov. 2, 2012
80319	56	Removal and Disposal of Surplus Materials	Nov. 2, 2012	
80224	57	Restoring Bridge Approach Pavements Using High-Density Foam	Jan. 1, 2009	Jan. 1, 2012
80271	58	Safety Edge	April 1, 2011	
80307	59	Seeding	Nov. 1, 2012	
80127	60	Steel Cost Adjustment	April 2, 2004	April 1, 2009
80255	61	Stone Matrix Asphalt	Jan. 1, 2010	Jan. 1, 2012
80143	62	Subcontractor Mobilization Payments	April 2, 2005	April 1, 2011
80317	63	Surface Testing of Hot-Mix Asphalt Overlays (NOTE: This special provision was previously named "Surface Testing of Pavements".)	Jan. 1, 2013	
80308	64	Synthetic Fibers in Concrete Gutter, Curb, Median and Paved Ditch	Nov. 1, 2012	
80286	65	Temporary Erosion and Sediment Control	Jan. 1, 2012	
80225	66	Temporary Raised Pavement Marker	Jan. 1, 2009	
80256	67	Temporary Water Filled Barrier	Jan. 1, 2010	Jan. 1, 2013
80301	68	Tracking the Use of Pesticides	Aug. 1, 2012	
80273	69	Traffic Control Deficiency Deduction	Aug. 1, 2011	
20338	70	Training Special Provisions	Oct. 15, 1975	
80318	71	Traversable Pipe Grate	Jan. 1, 2013	April 1, 2013
80270	72	Utility Coordination and Conflicts	April 1, 2011	Jan. 1, 2012
80288	73	Warm Mix Asphalt	Jan. 1, 2012	Nov. 1, 2012
80302	74	Weekly DBE Trucking Reports	June 2, 2012	
80289	75	Wet Reflective Thermoplastic Pavement Marking	Jan. 1, 2012	
80071	76	Working Days	Jan. 1, 2002	

The following special provisions are either in the 2013 Standard Specifications, the 2013 Recurring Special Provisions, or the special provisions Portland Cement Concrete, QC/QA of Concrete Mixtures, or Placing and Consolidating Concrete:

<u>File Name</u>	<u>Special Provision Title</u>	<u>New Location</u>	<u>Effective</u>	<u>Revised</u>
80275	Agreement to Plan Quantity	Article 202.07	Jan. 1, 2012	
80291	Calcium Chloride Accelerator for Class PP-2 Concrete	Recurring CS #28	April 1, 2012	
80237	Construction Air Quality – Diesel Vehicle Emissions Control	Articles 105.03 and 107.41	April 1, 2009	Jan. 2, 2012
80239	Construction Air Quality – Idling Restrictions	Articles 105.03 and 107.41	April 1, 2009	
80177	Digital Terrain Modeling for Earthwork Calculations	Recurring CS #32	April 1, 2007	
80272	Drainage and Inlet Protection Under Traffic	Articles 603.02 and 603.07	April 1, 2011	Jan. 1, 2012
80228	Flagger at Side Roads and Entrances	Articles 701.13 and 701.20	April 1, 2009	
80109	Impact Attenuators	Section 643	Nov. 1, 2003	Jan. 1, 2012
80110	Impact Attenuators, Temporary	Section 706	Nov. 1, 2003	Jan. 1, 2012
80203	Metal Hardware Cast into Concrete	Articles 503.02, 504.02, and 1006.13	April 1, 2008	Jan. 1, 2012
80290	Payrolls and Payroll Records	Recurring CS #5	Jan. 2, 2012	
80299	Portland Cement Concrete Inlay or Overlay	Recurring CS #29	April 1, 2012	
80280	Portland Cement Concrete Sidewalk	Article 424.07	Jan. 1, 2012	

<u>File Name</u>	<u>Special Provision Title</u>	<u>New Location</u>	<u>Effective</u>	<u>Revised</u>
80152	Self-Consolidating Concrete for Cast-In-Place Construction	The following special provisions: Portland Cement Concrete, QC/QA of Concrete Mixtures and Placing and Consolidating Concrete	Nov. 1, 2005	April 1, 2012
80132	Self-Consolidating Concrete for Precast and Precast Prestressed Products	The following special provisions: Portland Cement Concrete, QC/QA of Concrete Mixtures and Placing and Consolidating Concrete	July 1, 2004	April 1, 2012
80284	Shoulder Rumble Strips	Article 642.05	Jan. 1, 2012	
80285	Sidewalk, Corner or Crosswalk Closure	Articles 701.03, 701.15, and 1106.02	Jan. 1, 2012	
80075	Surface Testing of Pavements (Section 406 overlay portion will remain a special provision and will now be called "Surface Testing of HMA Overlays".)	Articles 407.09, 407.12, 420.10, 420.20, and 1101.10	April 1, 2002	Jan. 1, 2007
80287	Type G Inlet Box	Article 610.09	Jan. 1, 2012	

The following special provisions require additional information from the designer. The additional information needs to be included in a separate document attached to this check sheet. The Project Development and Implementation section will then include the information in the applicable special provision. The Special Provisions are:

- Bridge Demolition Debris
- Building Removal-Case I
- Building Removal-Case II
- Building Removal-Case III
- Building Removal-Case IV
- Completion Date
- Completion Date Plus Working Days
- DBE Participation
- Material Transfer Device
- Railroad Protective Liability Insurance
- Training Special Provisions
- Working Days

## HOT-MIX ASPHALT - DENSITY TESTING OF LONGITUDINAL JOINTS (BDE)

Effective: January 1, 2010

Revised: April 1, 2012

Description. This work shall consist of testing the density of longitudinal joints as part of the quality control/quality assurance (QC/QA) of hot-mix asphalt (HMA). Work shall be according to Section 1030 of the Standard Specifications except as follows.

Quality Control/Quality Assurance (QC/QA). Delete the second and third sentence of the third paragraph of Article 1030.05(d)(3) of the Standard Specifications.

Add the following paragraphs to the end of Article 1030.05(d)(3) of the Standard Specifications:

“Longitudinal joint density testing shall be performed at each random density test location. Longitudinal joint testing shall be located at a distance equal to the lift thickness or a minimum of 4 in. (100 mm), from each pavement edge. (i.e. for a 5 in. (125 mm) lift the near edge of the density gauge or core barrel shall be within 5 in. (125 mm) from the edge of pavement.) Longitudinal joint density testing shall be performed using either a correlated nuclear gauge or cores.

- a. Confined Edge. Each confined edge density shall be represented by a one-minute nuclear density reading or a core density and shall be included in the average of density readings or core densities taken across the mat which represents the Individual Test.
- b. Unconfined Edge. Each unconfined edge joint density shall be represented by an average of three one-minute density readings or a single core density at the given density test location and shall meet the density requirements specified herein. The three one-minute readings shall be spaced ten feet apart longitudinally along the unconfined pavement edge and centered at the random density test location.”

Revise the Density Control Limits table in Article 1030.05(d)(4) of the Standard Specifications to read:

"Mixture Composition	Parameter	Individual Test (includes confined edges)	Unconfined Edge Joint Density Minimum
IL-4.75	Ndesign = 50	93.0 – 97.4%	91.0%
IL-9.5, IL-12.5	Ndesign ≥ 90	92.0 – 96.0%	90.0%
IL-9.5, IL-9.5L, IL-12.5	Ndesign < 90	92.5 – 97.4%	90.0%
IL-19.0, IL-25.0	Ndesign ≥ 90	93.0 – 96.0%	90.0%
IL-19.0, IL-19.0L, IL-25.0	Ndesign < 90	93.0 – 97.4%	90.0%

SMA	Ndesign = 50 & 80	93.5 – 97.4%	91.0%
All Other	Ndesign = 30	93.0 - 97.4%	90.0% <sup>n</sup>

80246

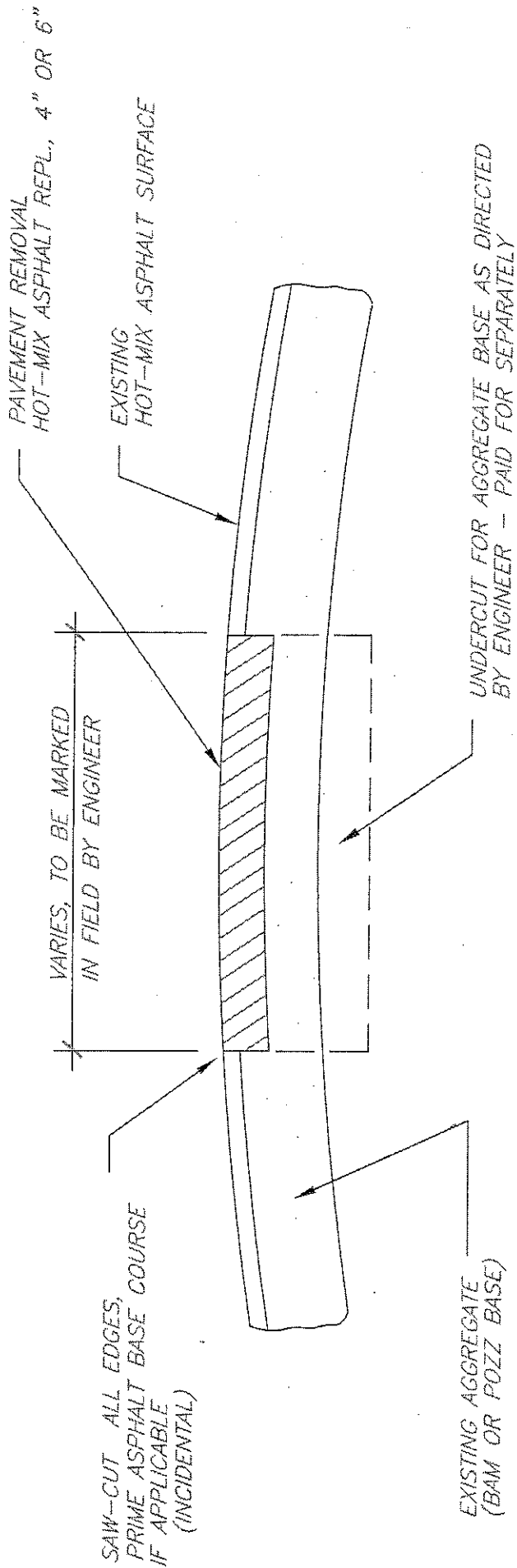

# CLASS D PATCHES, 4" or 6"

N.T.S.

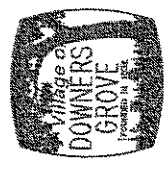

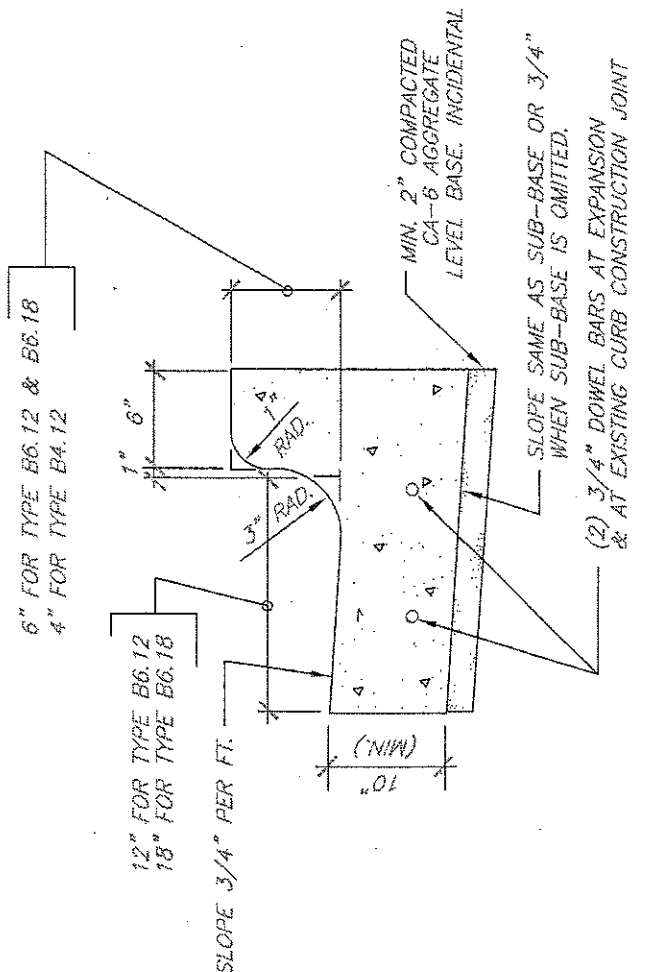

BARRIER CURB

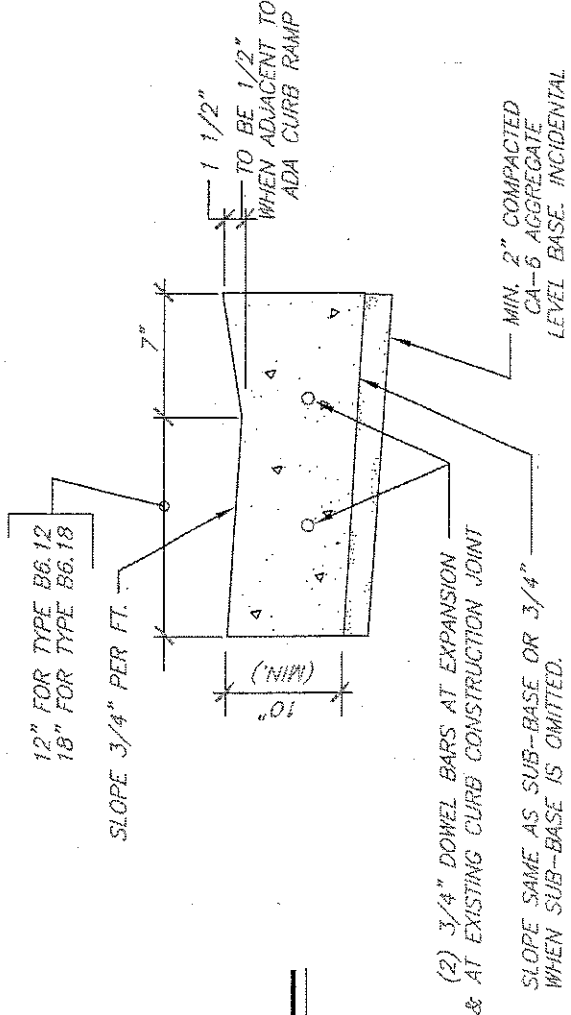

DEPRESSED CURB

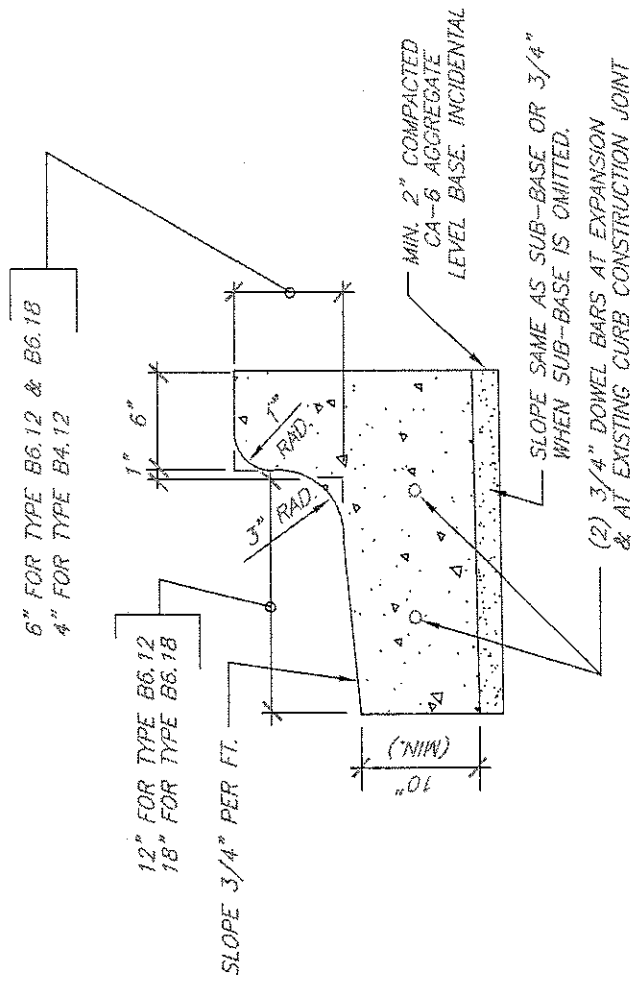

BARRIER CURB WITH REVERSED PITCH

**COMBINATION CONCRETE CURB AND GUTTER - BARRIER**

JOINT SPACING ON CENTERS:  
 15' FOR CONTRACTIONS  
 90' FOR EXPANSION

WHERE APPLICABLE NEW CURB SHALL BE TIED TO ADJACENT CONCRETE PAVEMENT OR BASE WITH NO. 6 (3/4") BARS AT 24" CENTERS IN ACCORDANCE WITH DETAILS FOR LONGITUDINAL CONSTRUCTION JOINT SHOWN ON STANDARD 420001

N.T.S.



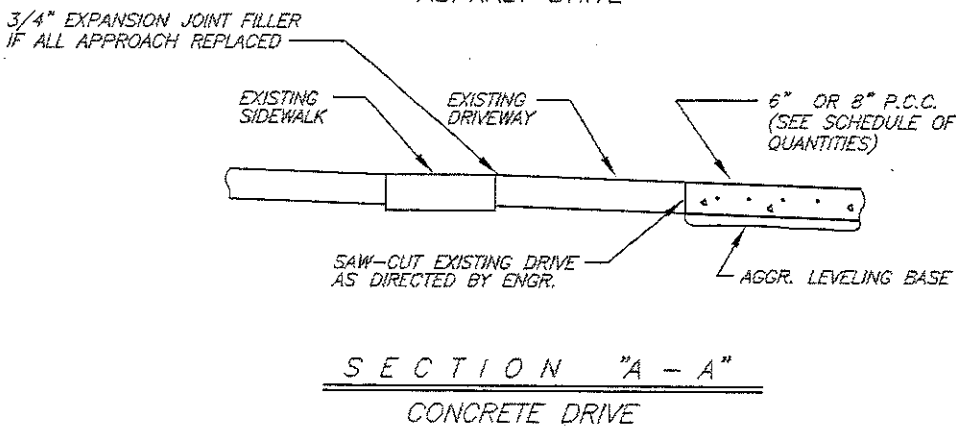
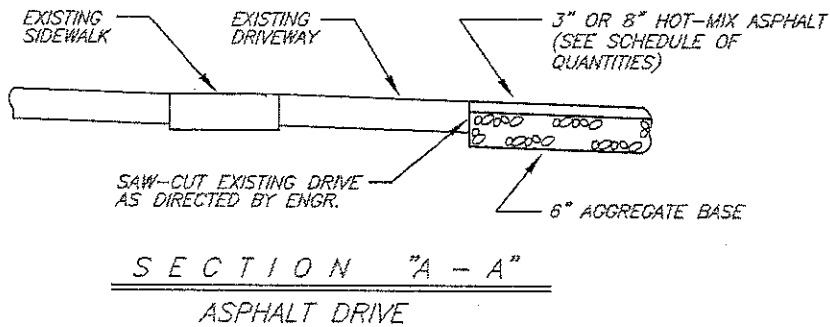
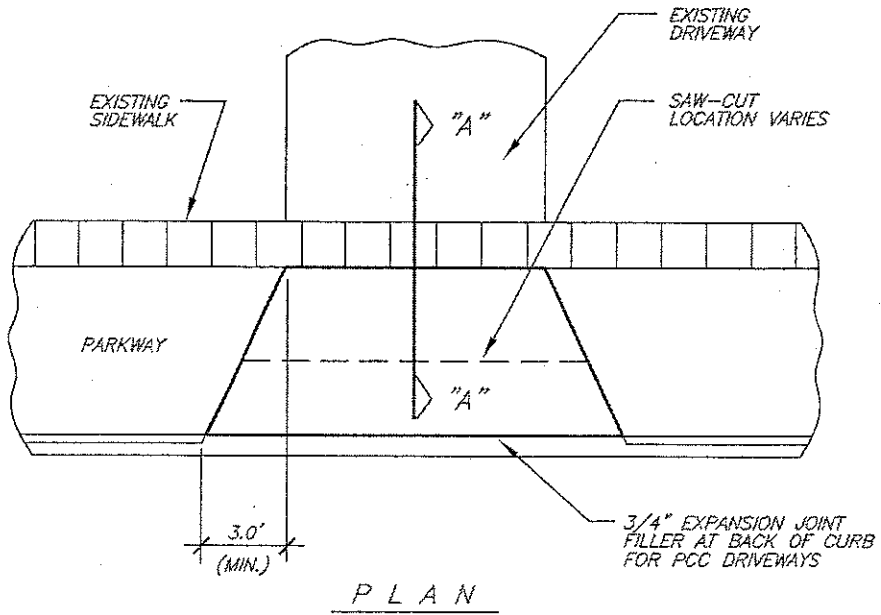

DRIVEWAY REMOVAL & REPLACEMENT

N.T.S.



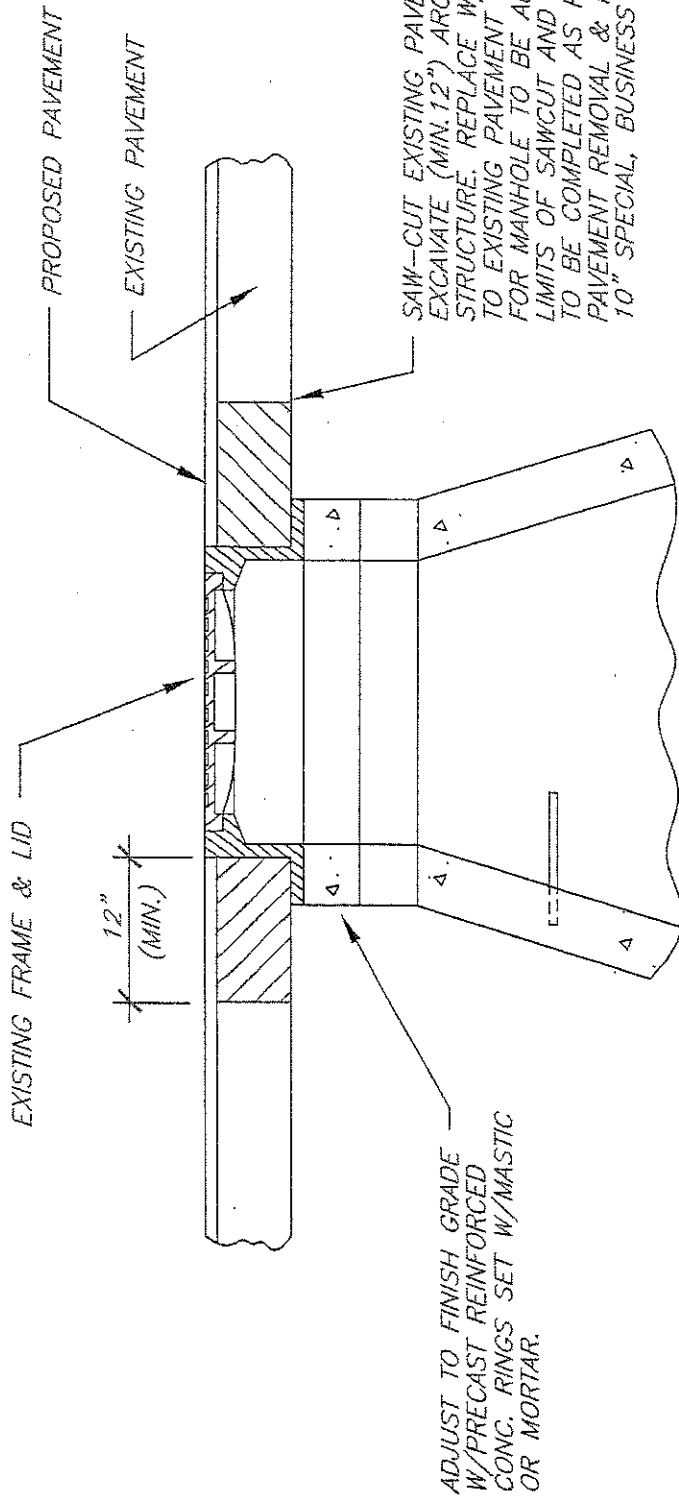

SAW-CUT EXISTING PAVEMENT.  
EXCAVATE (MIN. 12") AROUND  
STRUCTURE. REPLACE W/CONCRETE  
TO EXISTING PAVEMENT GRADE.  
FOR MANHOLE TO BE ADJUSTED, BUSINESS  
LIMITS OF SAWCUT AND CONCRETE REPLACEMENT  
TO BE COMPLETED AS PART OF ITEM FOR  
PAVEMENT REMOVAL & PCC REPLACEMENT  
10" SPECIAL, BUSINESS

ADJUST TO FINISH GRADE  
W/PRECAST REINFORCED  
CONC. RINGS SET W/MASTIC  
OR MORTAR.

NOTES:

1. AFTER MANHOLE HAS BEEN ADJUSTED AND IF STREET IS OPEN TO TRAFFIC, A TYPE 1 BARRICADE W/FLASHER SHALL BE PLACED AT EACH MANHOLE.
2. SANITARY MANHOLE AND MANHOLE TO BE ADJUSTED, BUSINESS TO BE SET W/MASTIC

MANHOLE ADJUSTMENT DETAIL

N.T.S.



VERIFY SIZE & TYPE IN  
FIELD. NO BRICK COLLARS  
USED FOR RECONNECTION.  
SAW-CUT EXISTING  
PIPES AS NEEDED

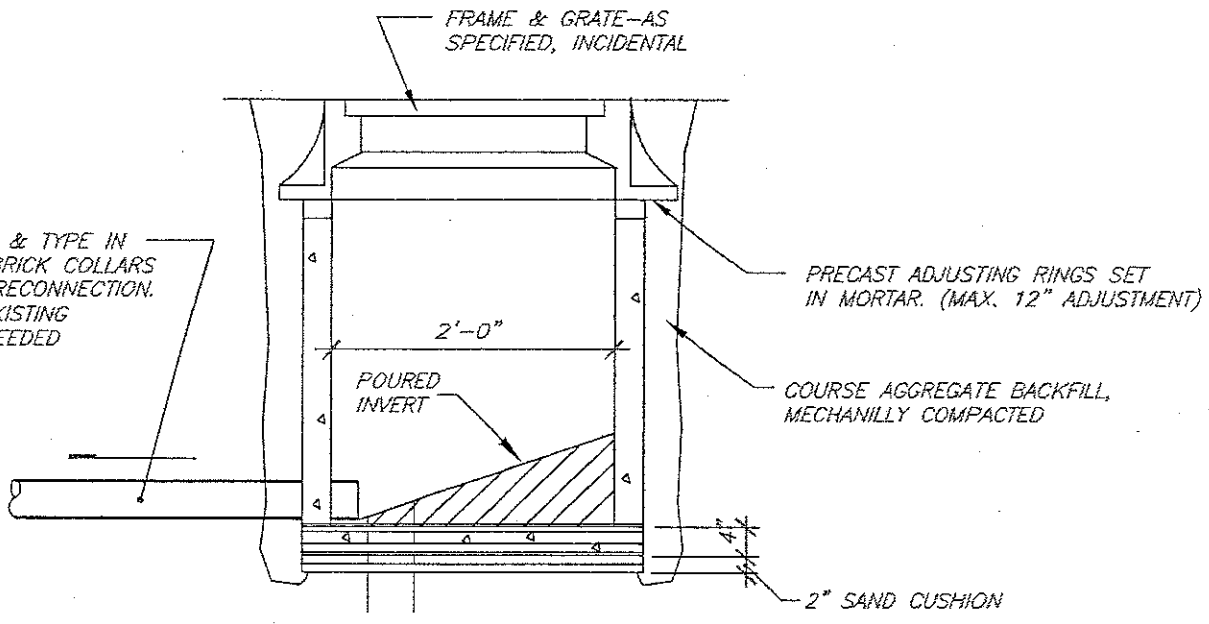

NOTE: INSIDE WALL OF INLET TO BE  
FLUSH WITH FACE OF CURB FOR TYPE I FRAME  
OR BACK OF CURB FOR TYPE 3 & TYPE II FRAME

## TYPE "A" INLET NEW/REPLACEMENT

N.T.S.

R.W.B  
06/08/05  
C:\CADFILES\RESURFACING\DETAILS



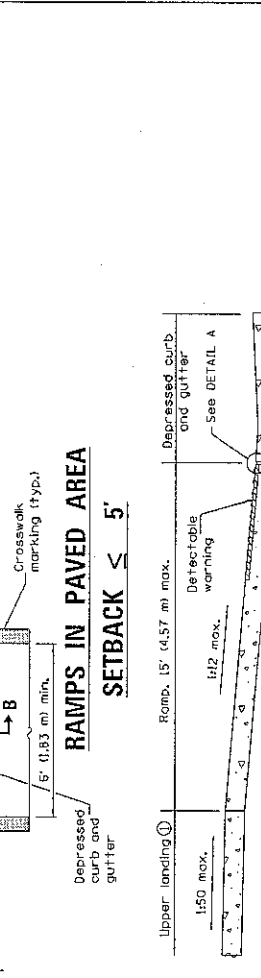
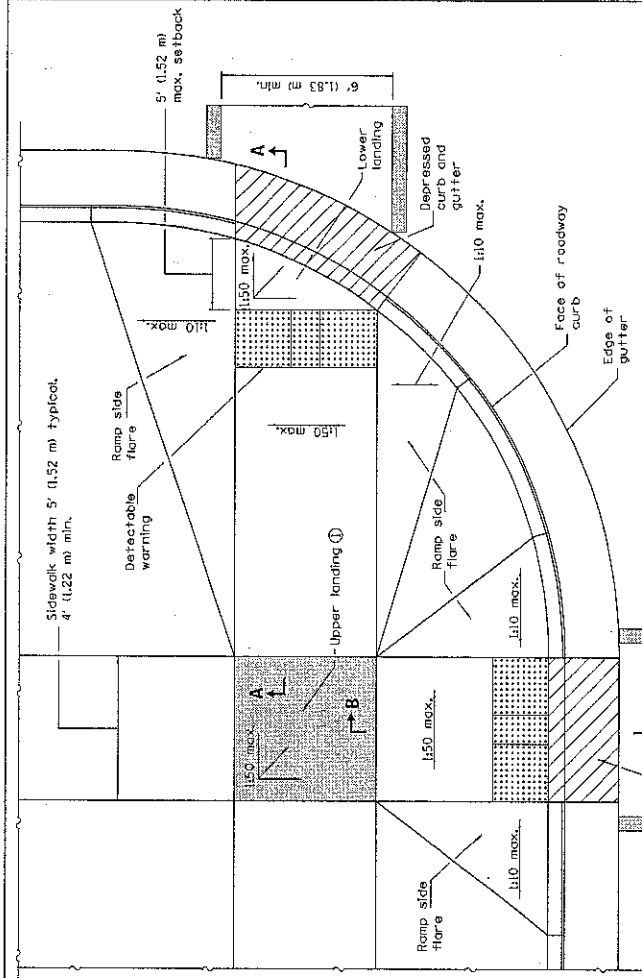

**RAMPS IN LANDSCAPED AREA**  
**SETBACK ≤ 5'**

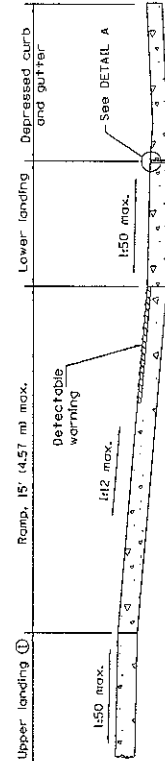

**SECTION A-A**

① Upper landing not required for ramp slopes flatter than 1:20.

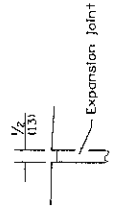

**DETAIL A**

**RAMPS IN PAVED AREA**  
**SETBACK ≤ 5'**

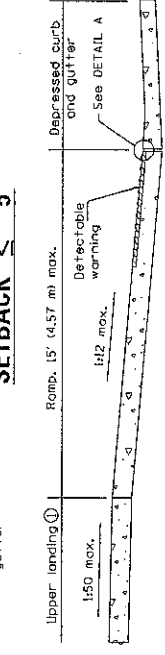

**SECTION B-B**

① Upper landing not required for ramp slopes flatter than 1:20.

**GENERAL NOTES**

All slope ratios are expressed as units of vertical displacement to units of horizontal displacement (V:H).

Where 1:50 maximum slope is shown, 1:64 is preferred.

See Standard 606001 for details of depressed curb adjacent to curb ramp.

All dimensions are in inches (millimeters) unless otherwise shown.

PERPENDICULAR CURB RAMPS FOR SIDEWALKS	
DATE	REVISIONS
1-1-13	Widened crosswalk markings to 6' (1.83 m) min. inside dimension. Rev. Gen. Notes. Completely revised and renamed standard.
1-1-12	

**SIDE CURB DETAIL**

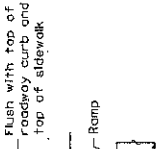

Illinois Department of Transportation  
 PASSED January 1, 2013  
 ENGINEER OF POLICY AND PROCEDURES  
 APPROVED [Signature]  
 ENGINEER OF DESIGN AND ENVIRONMENT  
 ISSUED 1-1-13

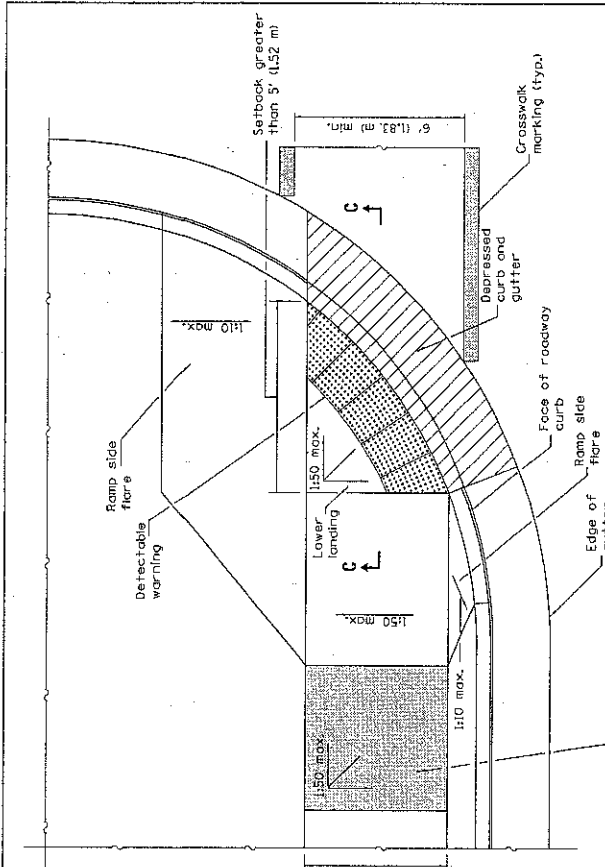

**RAMP IN LANDSCAPED AREA**  
**SETBACK > 5'**

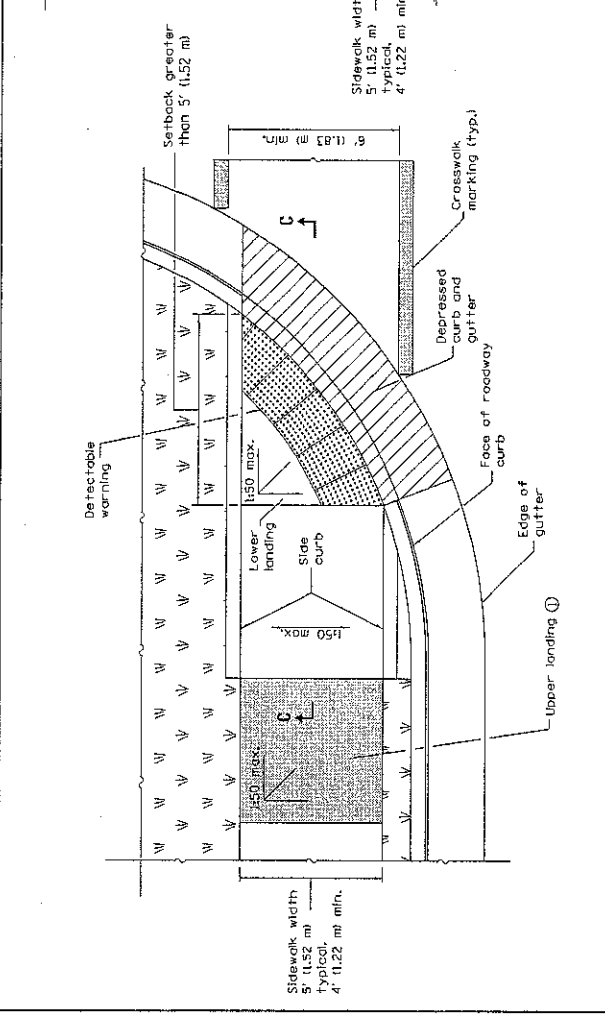

**RAMP IN PAVED AREA**  
**SETBACK > 5'**

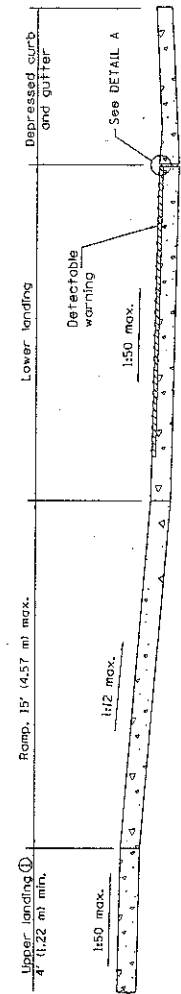

**SECTION C-C**

① Upper landing not required for ramp slopes flatter than 1:20.

PASSED APPROVED ENGINEER OF DESIGN AND ENVIRONMENT	JENNIFER L. J. 2013 ENGINEER OF POLICY AND PROCEDURE	ISSUED 1-1-97
	MICHAEL B. B. 2013 ENGINEER OF POLICY AND PROCEDURE	
	JENNIFER L. J. 2013 ENGINEER OF DESIGN AND ENVIRONMENT	
	JENNIFER L. J. 2013 ENGINEER OF DESIGN AND ENVIRONMENT	

Sidewalk width 5' (1.52 m) typical,  
4' (1.22 m) min.

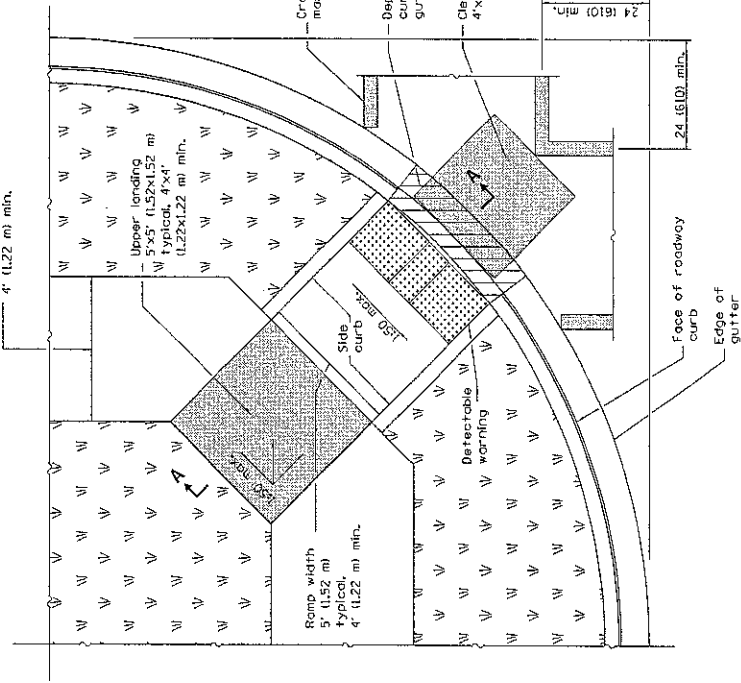

**RAMP IN LANDSCAPED AREA**

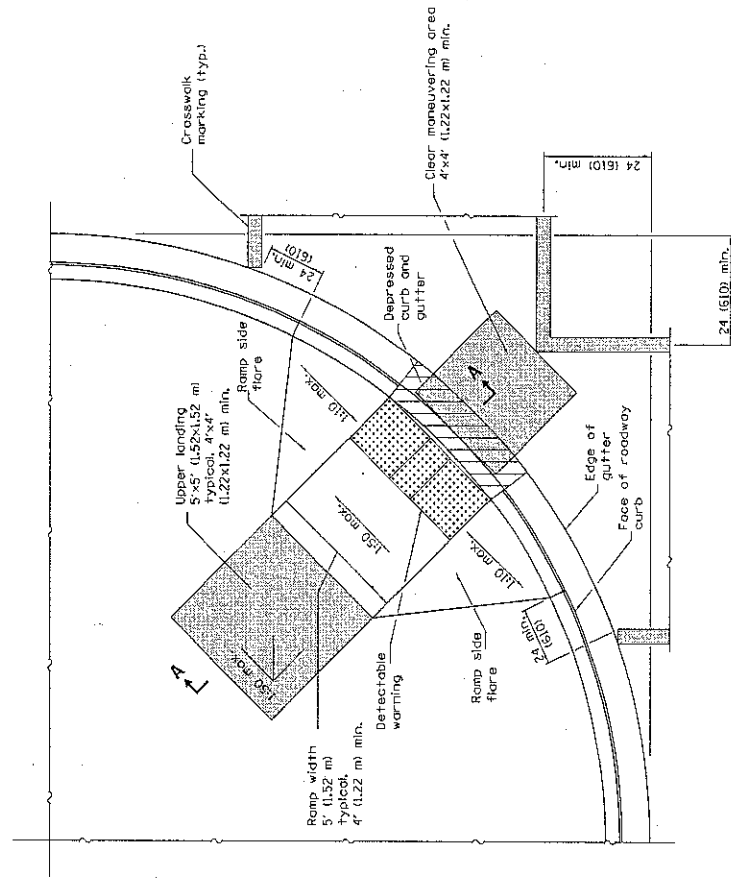

**RAMP IN PAVED AREA**

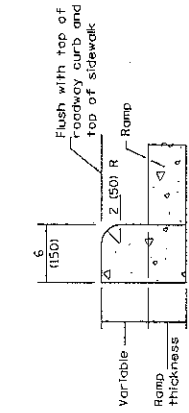

**SIDE CURB DETAIL**

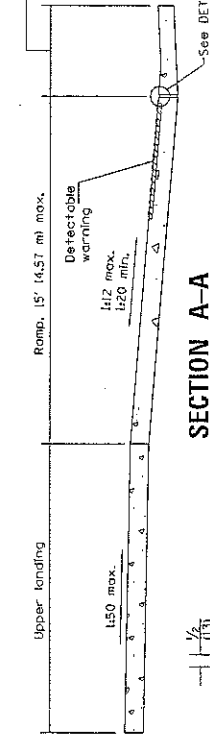

**SECTION A-A**

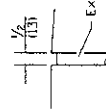

**DETAIL A**

**GENERAL NOTES**

This Standard shall only be used for curb radii of 20 ft. (6.1 m) or greater.

When 1:50 maximum slope is shown, 1:54 is preferred.

All slope ratios are expressed as units of vertical displacement to units of horizontal displacement (V:H).

See Standard 605001 for details of depressed curb adjacent to curb ramp.

All dimensions are in inches (millimeters) unless otherwise shown.

DATE	REVISIONS
1-1-13	Revised General Notes.
1-1-12	New standard.

**DIAGONAL CURB RAMPS FOR SIDEWALKS**

STANDARD 424006-01

Illinois Department of Transportation  
 PASSED January 1, 2013  
 APPROVED Michael S. Dwyer  
 ENGINEER OF POLICY AND PROCEDURES  
 APPROVED January 1, 2013  
 ENGINEER OF DESIGN AND ENVIRONMENT

ISSUED 1-1-12



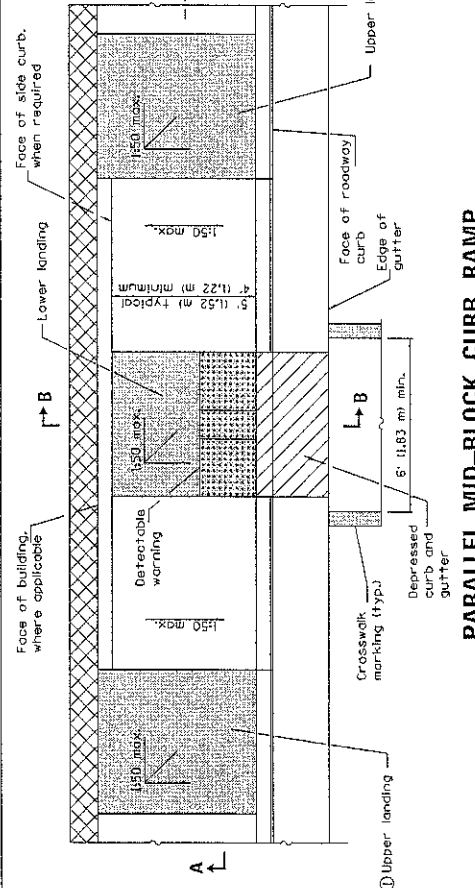

**PARALLEL MID-BLOCK CURB RAMP**

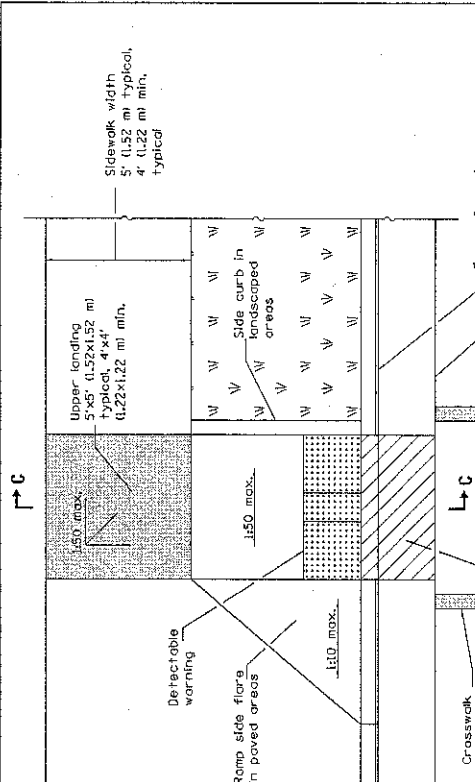

**PERPENDICULAR MID-BLOCK CURB RAMP**

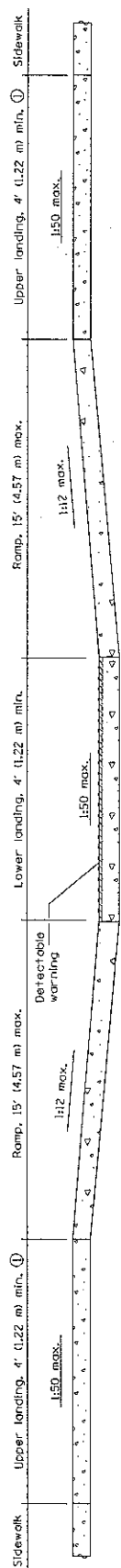

**SECTION A-A**

① Upper landing(s) not required for ramp slopes flatter than 1:20.

**SECTION B-B**

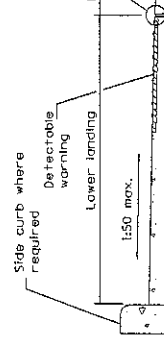

**SECTION C-C**

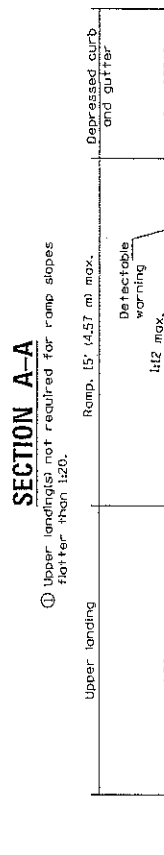

**GENERAL NOTES**

All slope ratios are expressed as units of vertical displacement to units of horizontal displacement (v/h).  
Where 1:50 maximum slope is shown, 1:64 is preferred.  
See Standard 606001 for details of depressed curb adjacent to curb ramp.  
All dimensions are in inches (millimeters) unless otherwise shown.

Illinois Department of Transportation PASSED APPROVED ENGINEER OF POLICY AND PROCEDURES ENGINEER OF DESIGN AND ENVIRONMENT	ISSUED 1-1-12
--	---------------

DATE	REVISIONS
1-1-13	Widened crosswalk markings to 6' (1.83 m) min. inside dimension. Rev. Gen. Notes.
1-1-12	New standard.

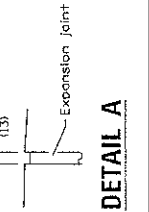

**DETAIL A**

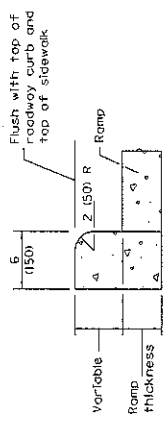

**SIDE CURB DETAIL**

**MID-BLOCK CURB RAMPS FOR SIDEWALKS**  
STANDARD 424016-01

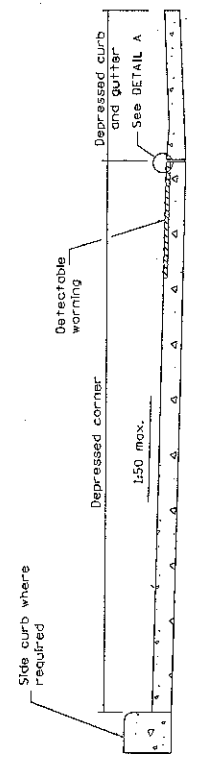
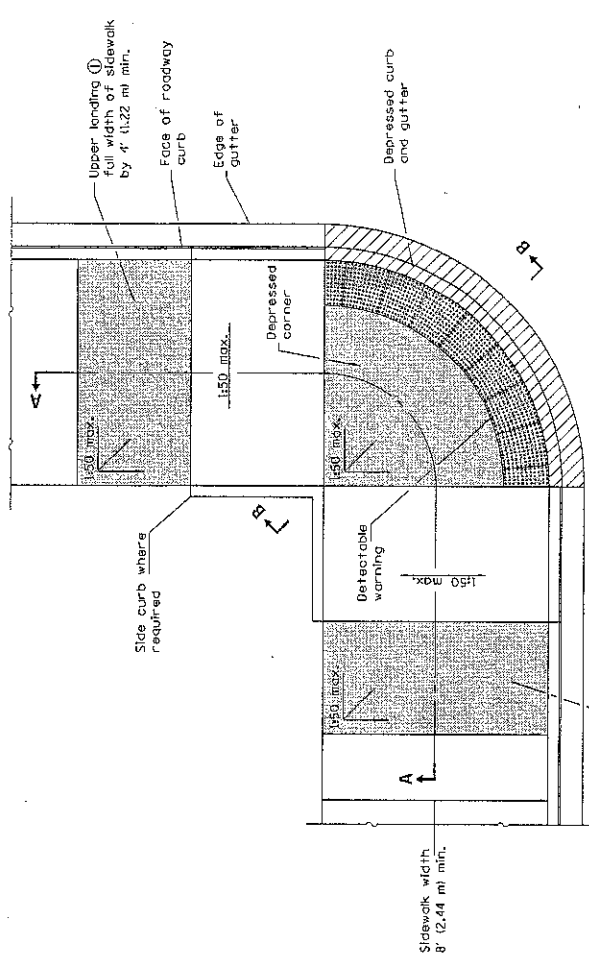

**SECTION B-B**

**DEPRESSED CORNER**

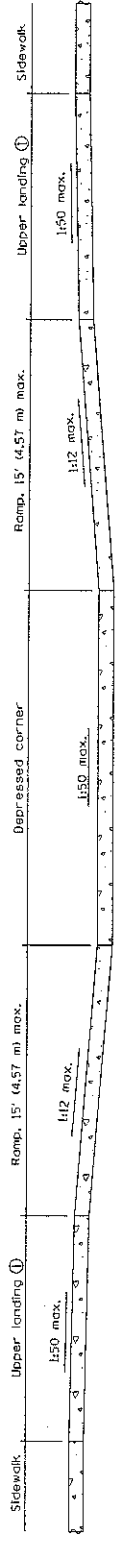

**SECTION A-A**

① Upper landing(s) not required for ramp slopes flatter than 1:20.



**DETAIL A**

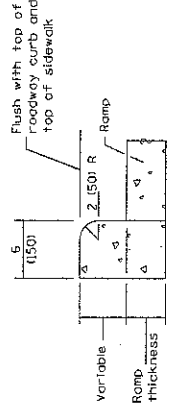

**SIDE CURB DETAIL**

**GENERAL NOTES**  
 All slope ratios are expressed as units of vertical displacement to units of horizontal displacement (V:H).  
 Where 1:50 maximum slope is shown, 1:64 is preferred.  
 See Standard 606001 for details of depressed curb adjacent to curb ramp.  
 All dimensions are in inches (millimeters) unless otherwise shown.

DATE	REVISIONS
1-1-13	Revised General Notes.
1-1-12	New standard.

**DEPRESSED CORNER FOR SIDEWALKS**

STANDARD 424021-01

Illinois Department of Transportation  
 PASSED JANUARY 1, 2013  
 ENGINEER OF POLICY AND PROCEDURES  
 APPROVED MICHAEL B. BROWN, P.E.  
 ISSUED 1-1-12  
 ENGINEER OF DESIGN AND ENVIRONMENT



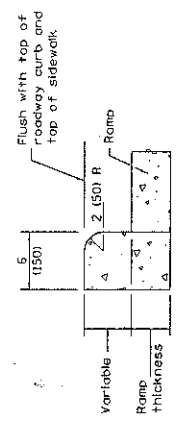

**SIDE CURB DETAIL**

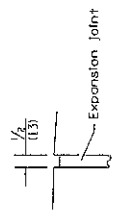

**DETAIL A**

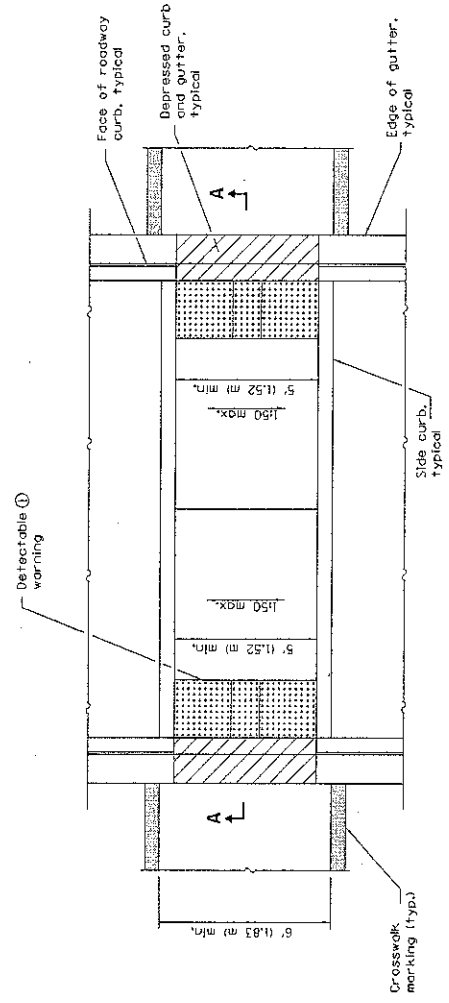

**MEDIAN PEDESTRIAN CROSSING**

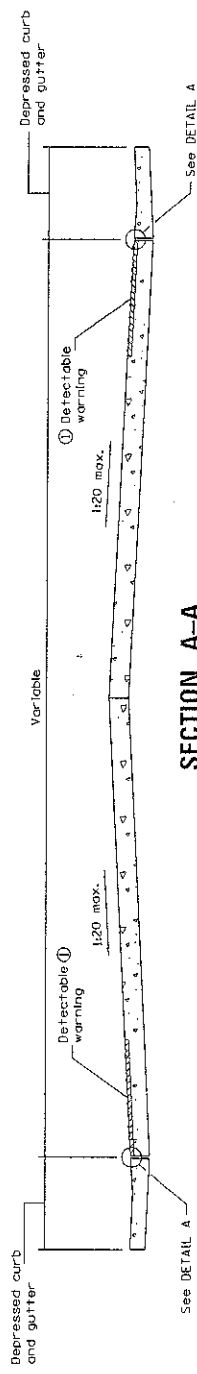

**SECTION A-A**

① Omit detectable warnings when distance between back of curbs is less than 6' (1.83 m).

**GENERAL NOTES**

All slope ratios are expressed as units of vertical displacement to units of horizontal displacement (V:H).  
 Where 1:50 maximum slope is shown, 1:64 is preferred.  
 See Standard 606001 for details of depressed curb adjacent to curb ramp.  
 All dimensions are in inches (millimeters) unless otherwise shown.

MEDIUM PEDESTRIAN CROSSINGS	
DATE	REVISIONS
1-1-12	Widened crosswalk to 6' (1.83 m) min. inside dimension.
	Revised General Notes.
1-1-12	New standard.

Illinois Department of Transportation  
 ISSUED 1-1-12  
 PASSED [Signature] 2013  
 ENGINEER OF POLICY AND PROCEDURES  
 APPROVED [Signature] 2013  
 ENGINEER OF DESIGN AND ENVIRONMENT

STANDARD 424031-01

- For precast reinforced concrete sections, this dimension may vary from the dimension given to plus 6 (150).

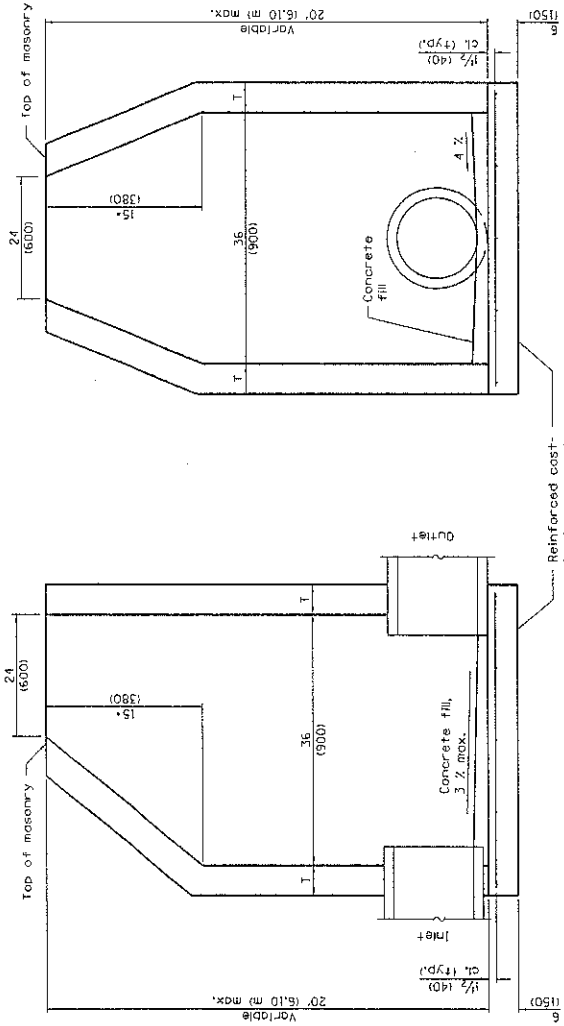

ELEVATION - CONCENTRIC

ELEVATION - ECCENTRIC

ALTERNATE MATERIALS FOR WALLS	T (min.)
Concrete Masonry Unit	5 (125)
Brick Masonry	8 (200)
Precast Reinforced Concrete Section	3 (75)
Cast-in-Place Concrete	6 (150)

**GENERAL NOTES**  
 Bottom slabs shall be reinforced with a minimum of 0.20 sq. in./ft. (420 sq. mm/m) in both directions with a maximum spacing of 12 (300).

Bottom slabs may be connected to the riser as determined by the fabricator; however, only a single row of reinforcement around the perimeter may be utilized.

See Standard 602601 for optional Precast Reinforced Concrete Flat Slab Top.  
 All dimensions are in inches (millimeters) unless otherwise shown.

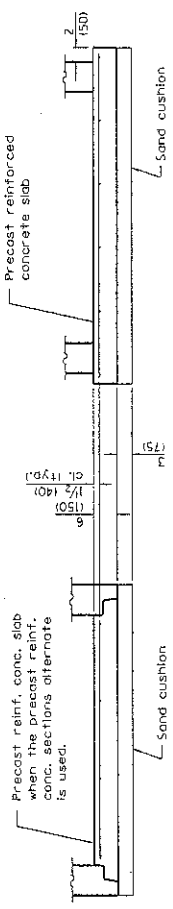

ALTERNATE BOTTOM SLAB

DATE	REVISIONS
1-1-11	Detailed reinf. in slabs. Added max. limit to height.
1-1-09	Revised general notes. Switched units to English (metric).

Illinois Department of Transportation  
 ISSUED 1-1-1-97  
 PREPARED BY: *[Signature]* 2011  
 ENGINEER OF PUBLIC WORKS  
 APPROVED BY: *[Signature]* 2011  
 ENGINEER OF DESIGN AND ENVIRONMENT

INLET - TYPE B

STANDARD 602305-03

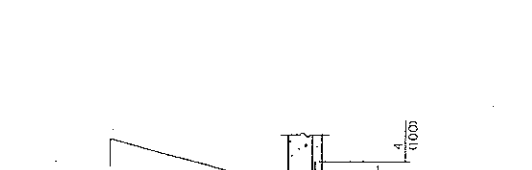
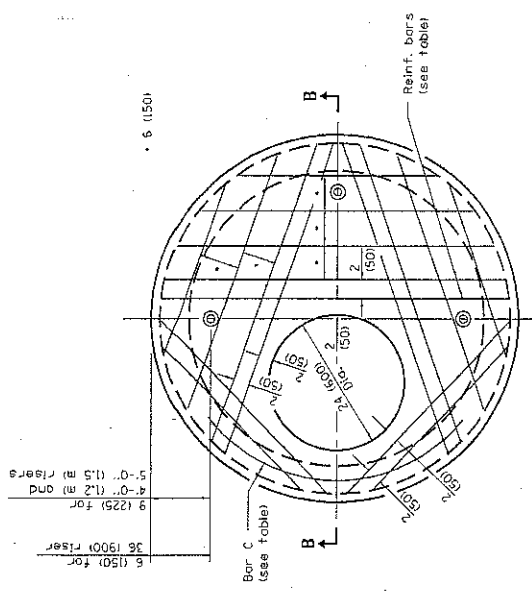

**LIFTING HOLE OR LIFTING LOOP**  
TYPICAL  
(3 required per slab)

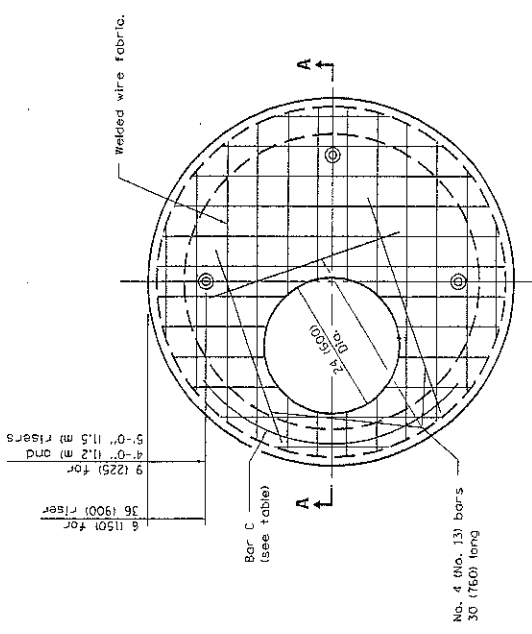

**PLAN (WELDED WIRE FABRIC)**

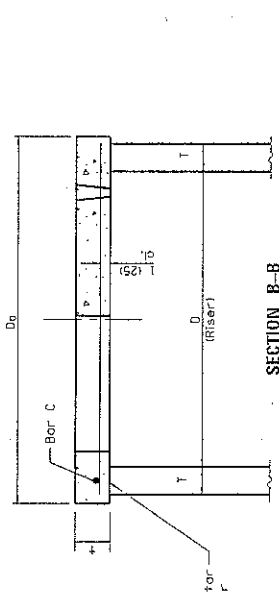

**SECTION B-B**

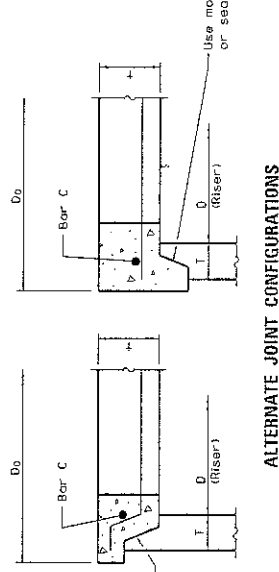

**ALTERNATE JOINT CONFIGURATIONS**

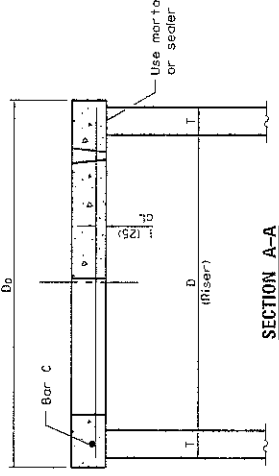

**SECTION A-A**

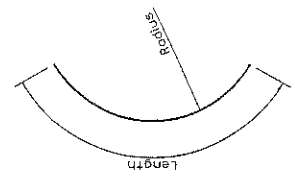

**BAR C**

**GENERAL NOTES**

The flat slab top may be used in lieu of the tapered tops shown on Standards 60200, 60201, 60206, 60206, 60240, or 60250 if the option of the Contractor or when field conditions prohibit the use of tapered tops.

All dimensions are in millimeters (inches) unless otherwise shown.

**TABLE**

D	T	D <sub>0</sub> (min.)	Reinforcement No. 4 (No. 13) Bar C	"A <sub>s</sub> " w.w.f. or Bar C size	No. 4 (No. 13) Bar C Length	Radius
36 (900)	4'-0" (1.2 m)	0 21	6 (150)	0.20 sq. in./ft. (425 sq. mm/m)	No. 4 (No. 13) 4'-0" (1.2 m)	19 (480)
4'-0" (1.2 m)	5'-0" (1.5 m)	0 +	6 (150)	0.35 sq. in./ft. (740 sq. mm/m)	No. 5 (No. 16) 4'-6" (1.35 m)	26 (660)
5'-0" (1.5 m)		0 21	8 (200)	0.35 sq. in./ft. (740 sq. mm/m)	No. 5 (No. 16) 5'-0" (1.5 m)	33 (810)

ISSUED 1-1-97

INTEGRITY DEPARTMENT OF TRANSPORTATION

PASSED: [Signature] 2009

ENGINEER OF PROJECT AND PROCEDURES: [Signature] 2009

APPROVED: [Signature] 2009

ENGINEER OF DESIGN AND ENVIRONMENT: [Signature]

DATE	REVISIONS
1-1-06	Switched units to English metric.
1-1-07	Soft converted metric reinforcement bars.

**PRECAST REINFORCED CONCRETE FLAT SLAB TOP**

STANDARD 602601-02









① Omit whenever duplicated by road work traffic control.

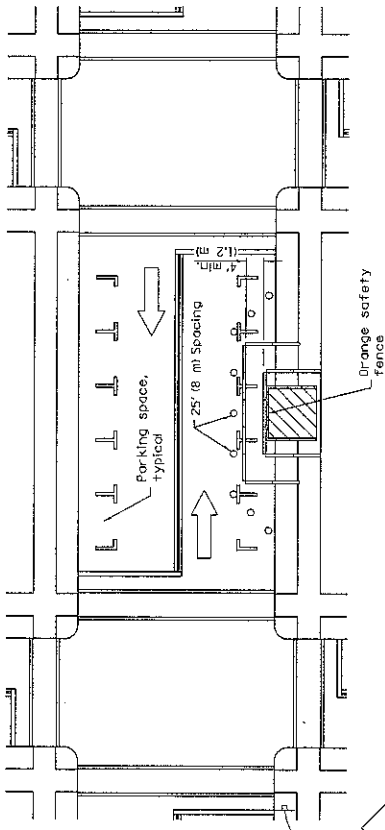

① ROAD CONSTRUCTION AHEAD  
W20-1103(10)-48 for contract construction projects

① ROAD WORK AHEAD  
W20-1101-48 for maintenance and utility projects

**SIDEWALK DIVERSION**

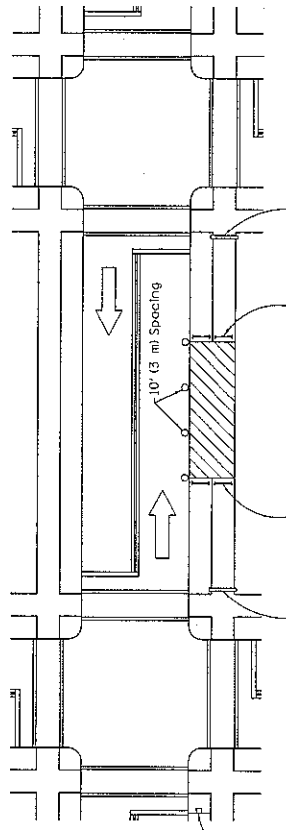

① ROAD CONSTRUCTION AHEAD  
W20-1103(10)-48 for contract construction projects

① ROAD WORK AHEAD  
W20-1101-48 for maintenance and utility projects

**SIDEWALK CLOSURE**

**SYMBOLS**

- Work area
- Sign on portable or permanent support
- Barricade or drum
- Cone, drum or barricade
- Type III barricade
- Detectable pedestrian channelizing barricade

**GENERAL NOTES**

This Standard is used where, at any time, pedestrian traffic must be rerouted due to work being performed.

This Standard must be used in conjunction with other Traffic Control & Protection Standards when roadway traffic is affected.

Temporary facilities shall be detectable and accessible.

The temporary pedestrian facilities shall be provided on the same side of the closed facilities whenever possible.

The SIDEWALK CLOSED / USE OTHER SIDE sign shall be placed at the nearest crosswalk or intersection to each end of the closure. Where the closure occurs at a corner, the signs shall be erected on the corners across the street from the closure. The SIDEWALK CLOSED signs shall be used at the ends of the actual closures.

Type II barricades and R11-2-4830 signs shall be positioned as shown in "ROAD CLOSED TO ALL TRAFFIC" Section Standard 701301.

All dimensions are in inches (millimeters) unless otherwise shown.

DATE	REVISIONS
1-1-12	Added SIDEWALK DIVERSION.
1-1-09	Modified appearance of plan views. Renamed Std.
1-1-09	Switched units to English (metric).
	702001 to 701901.

**SIDEWALK, CORNER OR CROSSWALK CLOSURE**

(Sheet 1 of 2)

STANDARD 701801-05

Illinois Department of Transportation  
 APPROVED: [Signature] 2012  
 ENGINEER OF SURVEYING  
 APPROVED: [Signature] 2012  
 ENGINEER OF DESIGN AND SURVEYING  
 ISSUED 1-1-97

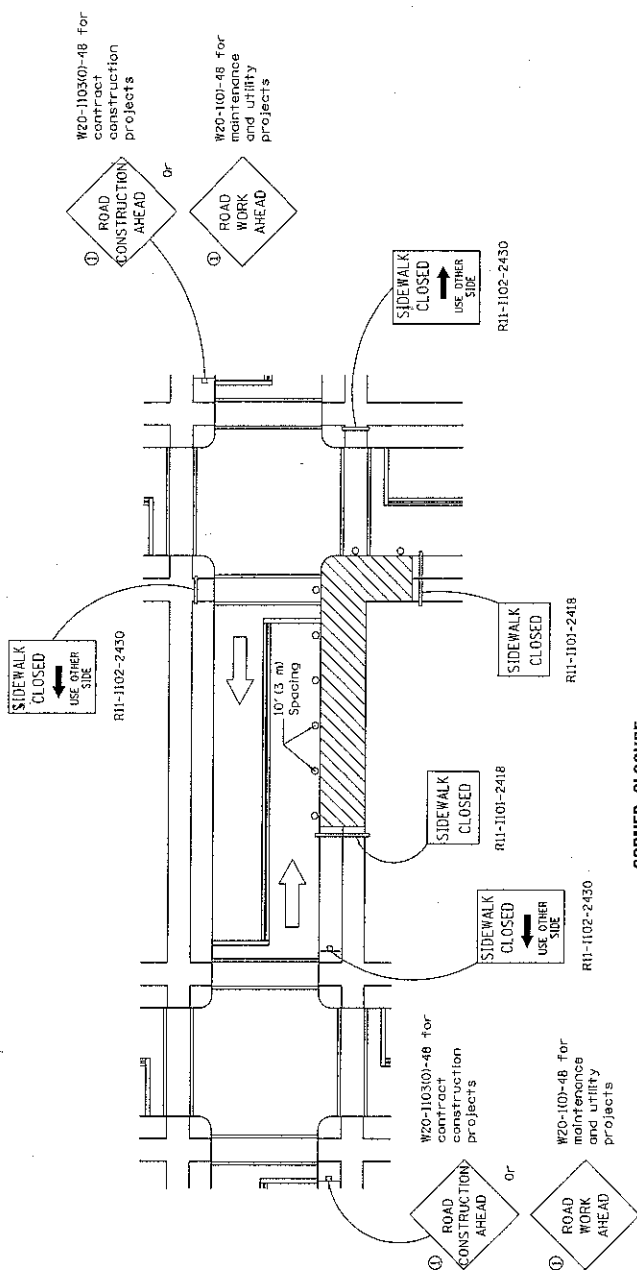

**CORNER CLOSURE**

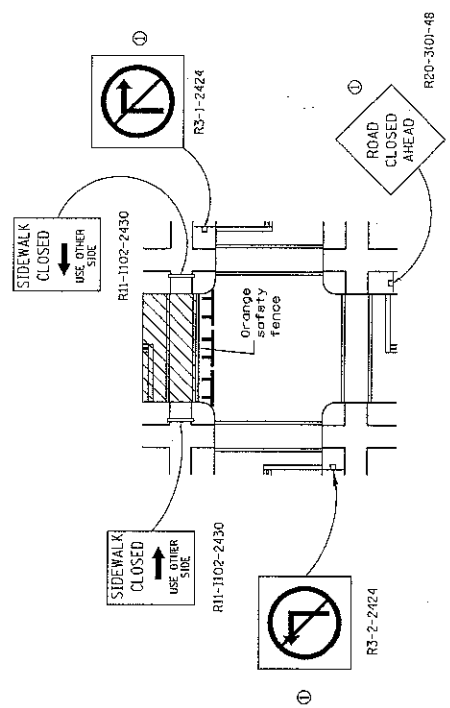

**CROSSWALK CLOSURE**

**SIDEWALK, CORNER OR CROSSWALK CLOSURE**  
 (Sheet 2 of 2)  
 STANDARD 701801-05

	APPROVED January 1, 2012 ENGINEER OF SAFETY ENGINEERING APPROVED January 1, 2012 ENGINEER OF DESIGN AND SURVEYMENT	ISSUED 1-1-97
	APPROVED January 1, 2012 ENGINEER OF SAFETY ENGINEERING APPROVED January 1, 2012 ENGINEER OF DESIGN AND SURVEYMENT	ISSUED 1-1-97
	APPROVED January 1, 2012 ENGINEER OF SAFETY ENGINEERING APPROVED January 1, 2012 ENGINEER OF DESIGN AND SURVEYMENT	ISSUED 1-1-97
	APPROVED January 1, 2012 ENGINEER OF SAFETY ENGINEERING APPROVED January 1, 2012 ENGINEER OF DESIGN AND SURVEYMENT	ISSUED 1-1-97

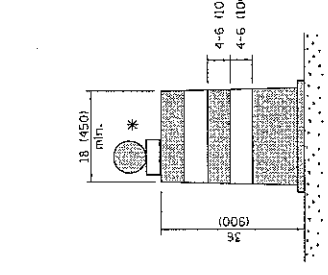

**REFLECTORIZED CONE**

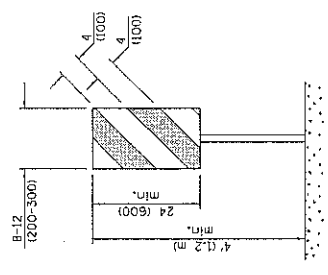

**FLEXIBLE DELINEATOR**

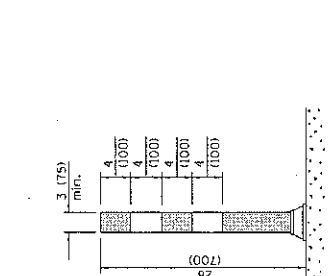

**REFLECTORIZED CONE**

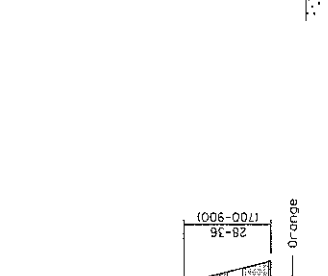

**FLEXIBLE DELINEATOR**

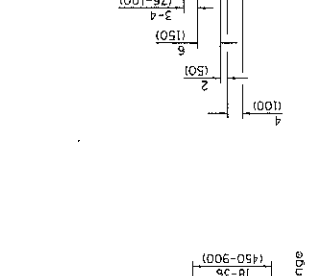

**FLEXIBLE DELINEATOR**

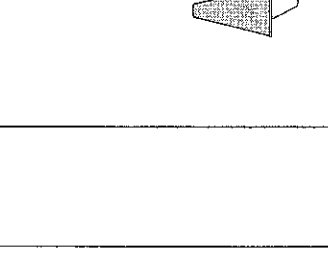

**FLEXIBLE DELINEATOR**

**CONE**

**REFLECTORIZED CONE**

**FLEXIBLE DELINEATOR**

**FLEXIBLE DELINEATOR**

**FLEXIBLE DELINEATOR**

**DRUM**

**VERTICAL PANEL POST MOUNTED**

**FLEXIBLE DELINEATOR**

**REFLECTORIZED CONE**

**CONE**

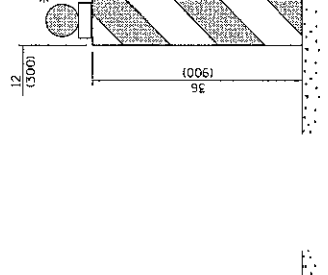

**TYPE I BARRICADE**

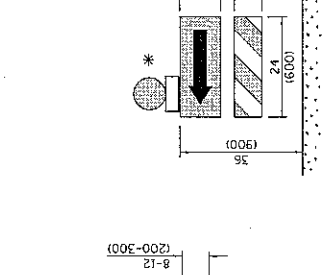

**TYPE II BARRICADE**

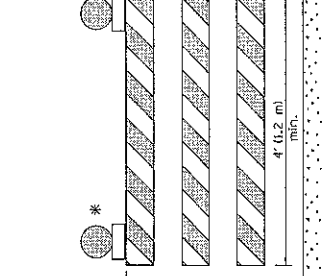

**TYPE III BARRICADE**

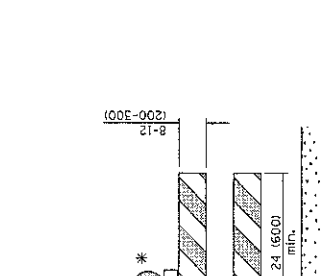

**TYPE II BARRICADE**

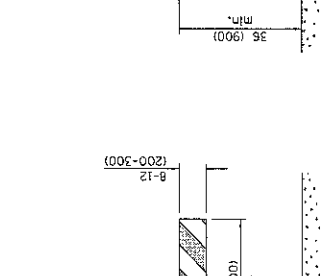

**TYPE II BARRICADE**

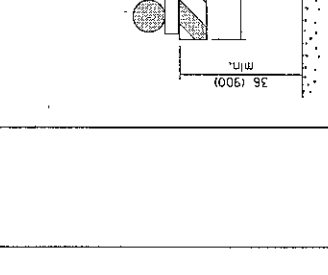

**TYPE II BARRICADE**

**TYPE I BARRICADE**

**TYPE II BARRICADE**

**TYPE III BARRICADE**

**TYPE II BARRICADE**

**TYPE II BARRICADE**

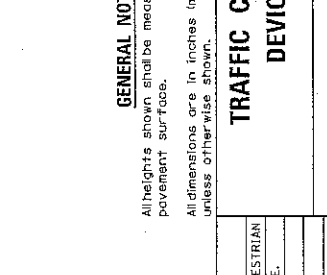

**DIRECTION INDICATOR BARRICADE**

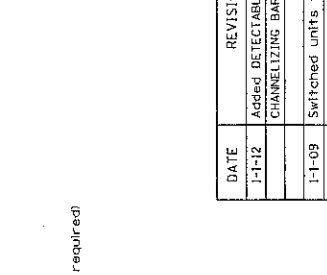

**DETECTABLE PEDESTRIAN CHANNELIZING BARRICADE**

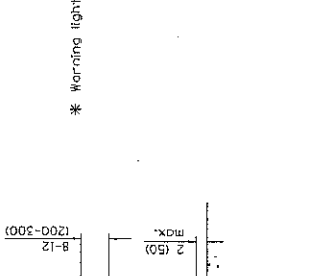

**DETECTABLE PEDESTRIAN CHANNELIZING BARRICADE**

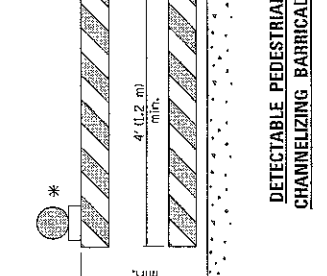

**DETECTABLE PEDESTRIAN CHANNELIZING BARRICADE**

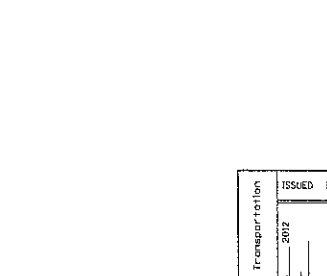

**DETECTABLE PEDESTRIAN CHANNELIZING BARRICADE**

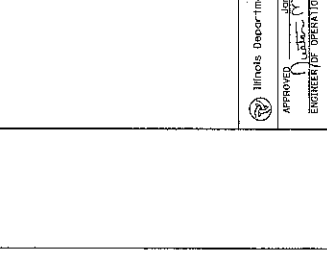

**DETECTABLE PEDESTRIAN CHANNELIZING BARRICADE**

\* Warning lights (if required)

**GENERAL NOTES**

All heights shown shall be measured above the pavement surface.  
All dimensions are in inches (millimeters) unless otherwise shown.

DATE	REVISIONS
1-1-12	Added DETECTABLE PEDESTRIAN CHANNELIZING BARRICADE.
1-1-09	Switched units to English (metric). Limited light on vertical panel.

**TRAFFIC CONTROL DEVICES**

STANDARD 701901-02 (Sheet 1 of 3)

Illinois Department of Transportation  
 APPROVED: [Signature] January 1, 2012  
 ENGINEER FOR OPERATIONS  
 APPROVED: [Signature] January 1, 2012  
 ENGINEER OF DESIGN AND ENVIRONMENT

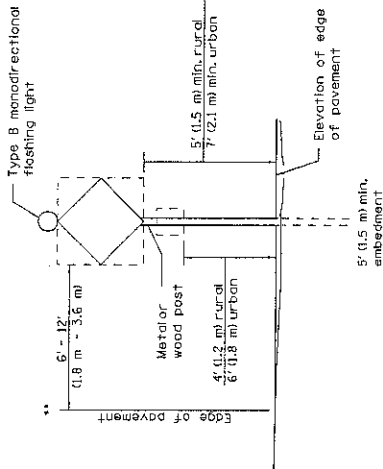

**POST MOUNTED SIGNS**

\*\* When curb or paved shoulder are present this dimension shall be 1600 to the face of curb or 6' (1.8 m) to the outside edge of the paved shoulder.

**SIGNS ON TEMPORARY SUPPORTS**

\*\*\* When work operations exceed four days, this dimension shall be 5' (1.5 m) min. If located behind other devices, the height shall be sufficient to be seen by motorists.

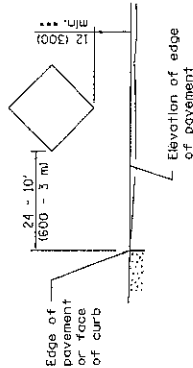

**HIGH LEVEL WARNING DEVICE**

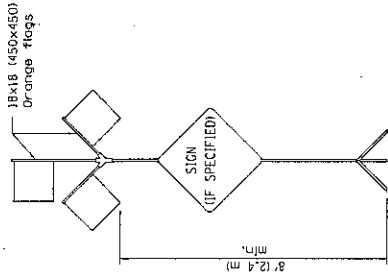

ROAD CONSTRUCTION NEXT X MILES

620-1101-6035

END CONSTRUCTION

620-2a101-6024

This signing is required for all projects 2 miles (3200 m) or more in length.

ROAD CONSTRUCTION NEXT X MILES sign shall be placed 500' (150 m) in advance of project limits.

END CONSTRUCTION sign shall be erected at the end of the job unless another job is within 2 miles (3200 m).

Dual sign displays shall be utilized on multi-lane highways.

**WORK LIMIT SIGNING**

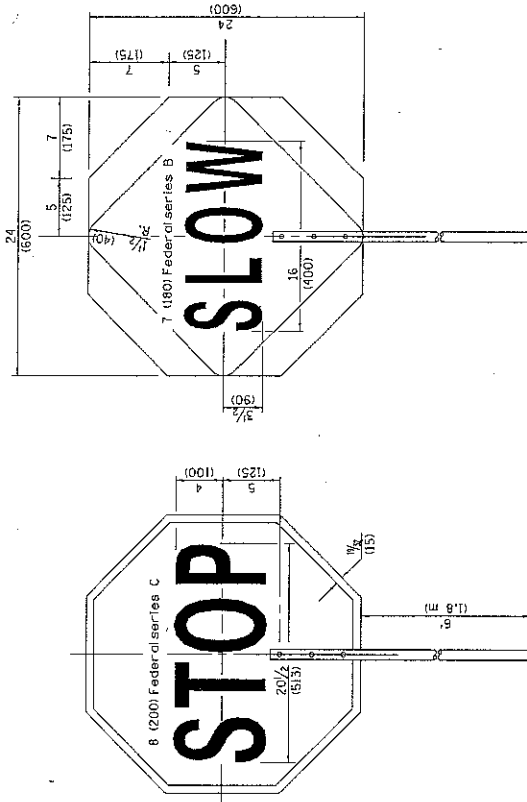

FRONT SIDE

REVERSE SIDE

All dimensions are in inches (millimeters) unless otherwise shown.

Illinois Department of Transportation		ISSUED	1-1-97
APPROVED	2012		
ENGINEER/OPERATIONS			
APPROVED	2012		
ENGINEER/DESIGN AND ENVIRONMENT			

**FLAGGER TRAFFIC CONTROL SIGN**

**TRAFFIC CONTROL DEVICES**

(Sheet 2 of 3)

STANDARD 701901-02

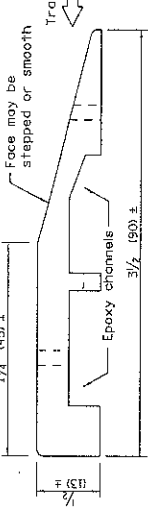
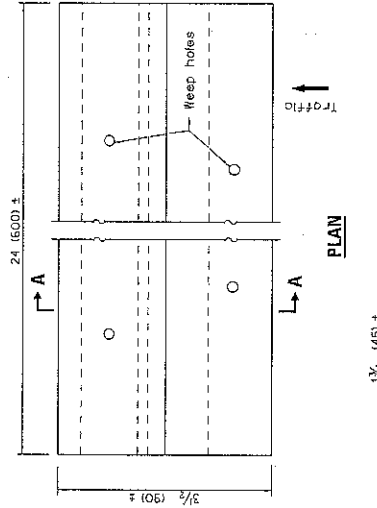

SECTION A-A

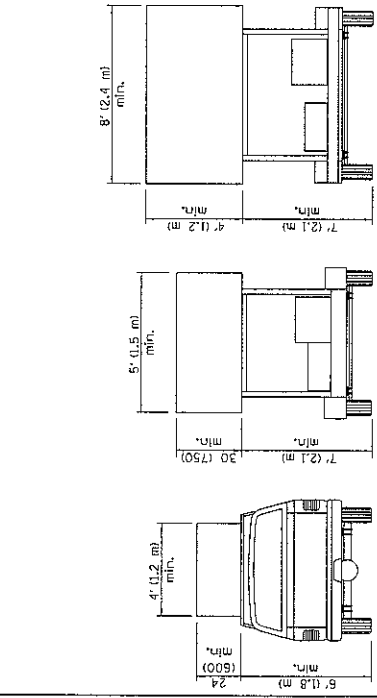

TYPE A  
ROOF  
MOUNTED

TYPE B  
ROOF OR TRAILER  
MOUNTED

TYPE C  
TRAILER  
MOUNTED

ARROW BOARDS

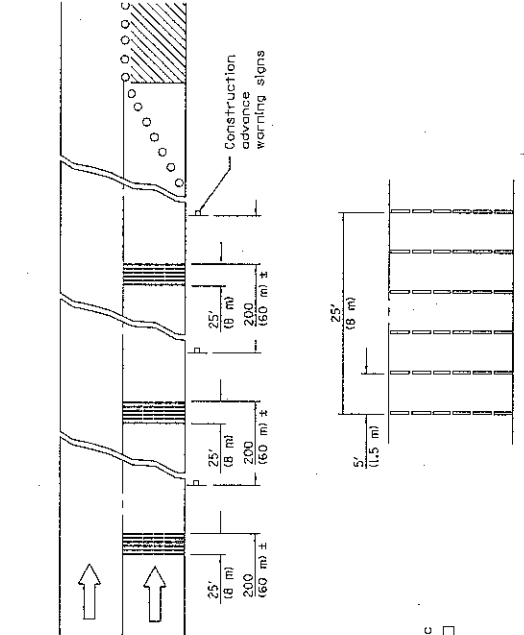

TYPICAL INSTALLATION

TEMPORARY RUMBLE STRIPS

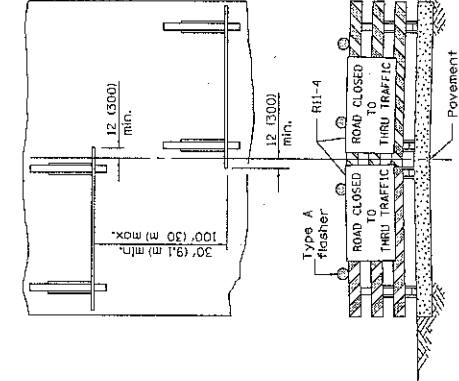
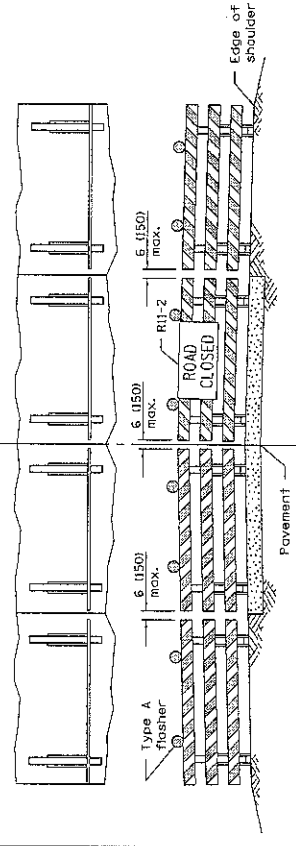

ReflectORIZED striping may be omitted on the back side of the barricades. If a Type III barricade with an attached sign panel which meets NCHRP 350 is not available, the sign may be mounted on an NCHRP 350 temporary sign support directly in front of the barricade.

ROAD CLOSED TO THRU TRAFFIC  
ReflectORIZED striping shall appear on both sides of the barricades. If a Type III barricade with an attached sign panel which meets NCHRP 350 is not available, the signs may be mounted on NCHRP 350 temporary sign supports directly in front of the barricades.

TYPICAL APPLICATIONS OF  
TYPE III BARRICADES CLOSING A ROAD

Illinois Department of Transportation  
 APPROVED: [Signature] January 1, 2012  
 ENGINEER OF OPERATIONS  
 APPROVED: [Signature] January 1, 2012  
 ENGINEER OF DESIGN AND ENVIRONMENT  
 ISSUED: 1-1-97

TRAFFIC CONTROL  
DEVICES

(Sheet 3 of 3)

STANDARD 701901-02

All dimensions are in inches (millimeters) unless otherwise shown.



2013 RESURFACING (A)  
SCHEDULE OF QUANTITIES

STREET	FROM	TO	LENGTH (FT)	WIDTH (FT)	TOT. IMP. AREA (SY)	HMA SURF. CSE. MIX D (TON)	MIN. THICKNESS (IN)	LEVEL BIND (TON)	AVG. THICKNESS (IN)
41ST ST	MAIN ST	ELM ST	1379	19-27	3614	304	1.50	152	0.75
59TH ST	MAIN ST	FAIRVIEW AVE	3942	34	16534	1620	1.75	694	0.75
61ST ST	W. OF PLYMOUTH ST	DUNHAM RD	1400	25-28	4624	388	1.50	194	0.75
67TH PL	DUNHAM RD	POWELL ST	535	28.5	1721	145	1.50	72	0.75
68TH PL	POWELL ST	WEST END	353	28	1131	95	1.50	48	0.75
BARRETT ST	67TH ST	CUL DE SAC S. OF 68TH	1172	28	4301	361	1.50	181	0.75
BELLE AIRE LN	OGDEN AVE	BELLE AIRE SCHOOL	2386	21-40	6487	545	1.50	272	0.75
BROOKSIDE LN	VENARD RD	SARATOGA AVE	885	28	2823	237	1.50	119	0.75
CHASE AVE	LIMIT S. OF MAPLE AVE	N. OF MAPLE AVE	663	28	2311	194	1.50	129	1.00
COMMERCE DR	WARRENVILLE RD	N. CUL DE SAC	612	22-28	1823	153	1.50	77	0.75
DUCHES CT	BROOKSIDE LN	N. CUL DE SAC	425	28	1369	115	1.50	57	0.75
HIGHLAND AVE	OGDEN AVE	HIGHLAND SCHOOL	2536	21-27	6710	564	1.50	319	0.85
HILLCREST RD	61ST ST	S. CUL DE SAC	744	28	2831	238	1.50	119	0.75
LINDLEY ST	OGDEN AVE	NORTH END	1369	17-28	3298	277	1.50	157	0.85
PERSHING AVE	S. OF PRAIRIE AVE	PRAIRIE AVE	576	21	1382	116	1.50	58	0.75
POWELL ST	67TH ST	S. OF 68TH PL	1310	28	4172	350	1.50	175	0.75
RIDGE CT	61ST ST	N. CUL DE SAC	167	28	675	57	1.50	28	0.75
WOODWARD AVE	PRAIRIE AVE	WARREN AVE	1361	22	3487	293	1.50	146	0.75

Totals> 21815 69293 6052 2997

Miles> 4.13

SCHEDULE OF QUANTITIES

2013 RESURFACING (A)  
SCHEDULE OF QUANTITIES

STREET	BIT, PRIME AGG, PRIME CL D, Ty 4 CL D, Special CL D, Ty 4 CL D, Special CL D, Ty 4 CL D, Special PAVE REM & HMA PGE SPECIAL HAUL SPECIAL CURB REM. C & G TY B-4.12										
	(GAL)	(TON)	4" (SY)	4" (SY)	6" (SY)	6" (SY)	REPL 8" (SY)	(CY)	WASTE (LOAD)	(LF)	(LF)
41ST ST	542	7	1050	17				11			
59TH ST	2480	33	735		529	58	42		1	2898	
61ST ST	694	9	385		79	63	21			454	
67TH PL	258	3	343							447	
68TH PL	170	2	289							253	
BARRETT ST	645	9	1365	98				158	2	2439	
BELLE AIRE LN	973	13	2286	147				27	1	16	
BROOKSIDE LN	423	6	723	14	32			16	11	1757	1732
CHASE AVE	347	5	896	17				137	2	773	
COMMERCE DR	273	4	609	61						515	
DUCHESS CT	205	3	420							809	
HIGHLAND AVE	1007	13	1995	158				21	2	158	
HILLCREST RD	425	6	315	34						634	
LINDLEY ST	495	7	1386	42				32	1	32	
PERSHING AVE	207	3	723	43				11			
POWELL ST	626	8	1575	74				210	1	2570	
RIDGE CT	101	1	53	21						137	
WOODWARD AVE	523	7	1367	105				26		8	
	10394	139	16515	873	640	121	79	649	21	13900	2541

SCHEDULE OF QUANTITIES

2013 RESURFACING (A)  
SCHEDULE OF QUANTITIES

STREET	C & G TY M-6.12 (LF)	C & G TY B-6.12 (LF)	C & G TY B-6.12 REINFORCE(LF)	C & G TY B-6.12 (LF)	M.H. ADJ. (EA)	M.H. ADJ. W/NEW TY 1 FR (EA)	SPECIAL (EA)	M.H. ADJ. RECON (EA)	M.H. IN. ADJ. (EA)	IN. ADJ. W/NEW TY 3 FR (EA)
41ST ST										
59TH ST	2164	95	446	193	3	10	2	12	1	6
61ST ST		443		11	4	4	1			2
67TH PL		426		21	1	1				2
68TH PL		232		21	1	1				1
BARRETT ST		2419		20	3	3			1	2
BELLE AIRE LN		16			4	4				
BROOKSIDE LN		15		10	4	4				2
CHASE AVE		539	168	66	1	1				2
COMMERCE DR		425	89		1	1				3
DUCHESS CT					1	1				
HIGHLAND AVE	16	58	84		7	7				1
HILLCREST RD		624		11						3
LINDLEY ST		32			1	1				
PERSHING AVE					1	1				
POWELL ST		2480		90	1	1				5
RIDGE CT		137								1
WOODWARD AVE		8			6	6	2			1
	2180	7949	787	443	49	49	17	1	1	21
										25

SCHEDULE OF QUANTITIES

2013 RESURFACING (A)  
SCHEDULE OF QUANTITIES

STREET	IN. ADJ W/ NEW TY 3 V FR (EA)	W/ NEW TY 3 FR (EA)	INLET RECON NEW 2' IN. W/ TY 3 FR (EA)	NEW 3' IN. W/ TY 3 FR (EA)	STORM SEWER INLET FILTERS 6 IN (LF)	HMA SURF.REM. CLEANING (EA)	HMA SURF.REM. 1.75' (SY)	HMA SURF.REM. 2' (SY)
41ST ST						2	2863	15484
59TH ST	1		3					4624
61ST ST	1							1721
67TH PL	2							1131
68TH PL	1							4301
BARRETT ST						2	4476	1571
BELLE AIRE LN						2		
BROOKSIDE LN						1		
CHASE AVE			1		30		2311	
COMMERCE DR							1258	
DUCHESS CT						2		
HIGHLAND AVE							6710	
HILLCREST RD	1							2831
LINDLEY ST							3298	
PERSHING AVE							1382	
POWELL ST			2	1		2		4172
RIDGE CT							675	
WOODWARD AVE							3487	
	6	4	3	1	30	11	26460	35835

SCHEDULE OF QUANTITIES

2013 RESURFACING (A)  
SCHEDULE OF QUANTITIES

STREET	HMA SURF.REM. 2.25" (SY)	HMA SURF.REM. 2.5" (SY)	HMA SURF.REM. VARI 1.5"-2.5"(SY)	CR.JT.&FLAN (TON)	SIDEWALK REMOVE (SF)	SIDEWALK 5" (SF)	SIDEWALK 6" (SF)	SIDEWALK 8" (SF)	DETECTABLE WARNINGS (\$F)	DÉCOR PAVER DRIVE (SY)
41ST ST		751			1288	1288			144	
59TH ST		1050			5489	5324	77	26	312	
61ST ST					1391	1118			56	
67TH PL					1004	798	103		32	2
68TH PL					577	515			32	
BARRETT ST				5	2086	1803	283		96	
BELLE AIRE LN		440			695	695			56	
BROOKSIDE LN		1602	1418		2209	1803	335		80	36
CHASE AVE					695	695			64	
COMMERCE DR	565				258	103		155		
DUCHESS CT		670	789							
HIGHLAND AVE					206	206			32	4
HILLCREST RD					345	155	52		16	3
LINDLEY ST										
PERSHING AVE										
POWELL ST				5	2936	2189	747		56	13
RIDGE CT					464	386			16	
WOODWARD AVE					361	361			32	
	565	4513	2207	10	20004.0	17439.0	1597.0	181.0	1024.0	58.0

SCHEDULE OF QUANTITIES

2013 RESURFACING (A)  
SCHEDULE OF QUANTITIES

STREET	DÉCOR PAVER SIDEWALK (SY)	AGG. SHOULD (TON)	PKWY REST (SY)	SUPPLEMENTAL WATER (UNIT)	TEMP HMA RAMP (SY)	HMA ROOT PRUNE (EA)	HMA DRIVE REMOVE (SY)	HMA DRIVE 3" (SY)	HMA DRIVE 8" (SY)	PCC DRIVE REMOVE (SY)
41ST ST		98	147				153	119	34	50
59TH ST			1440	1	17		38	38		
61ST ST		8	334	1						
67TH PL			257	1						133
68TH PL			177	1						32
BARRETT ST			1371	1			40	40		825
BELLE AIRE LN		169	70							7
BROOKSIDE LN			1079	1		1	117	117		231
CHASE AVE			366	1			147	78	69	
COMMERCE DR			198	1	5		125	21	104	
DUCHESS CT			378	1			149	149		113
HIGHLAND AVE		180	126				109		109	
HILLCREST RD	1		311	1			69	69		99
LINDLEY ST		97	14							
PERSHING AVE		41								
POWELL ST			1468	1		1				625
RIDGE CT			109	1						5
WOODWARD AVE		96	38							
	1.0	689	7883	12	22	2	947	631	316	2120

SCHEDULE OF QUANTITIES

2013 RESURFACING (A)  
SCHEDULE OF QUANTITIES

STREET	PCC DRIVE 6" (SY)	PCC DRIVE 8" (SY)	DETECTOR LOOP TY 1 (LF)	SHORT TERM PAVE MARK (LF)	TEMP PAVE MARK LET & SYM (SF)	WORKZONE MARK REM (SF)	YEL. PAVT. MARK LINE 4" (LF)	WH. PAVT. MARK LINE 4" (LF)
41ST ST								
59TH ST	30	20	210	240	187	266	6818	
61ST ST							1820	870
67TH PL	133							
68TH PL	32							
BARRETT ST	825							40
BELLE AIRE LN	7						140	
BROOKSIDE LN	231							
CHASE AVE								
COMMERCE DR								
DUCHESS CT	113							
HIGHLAND AVE								
HILLCREST RD	99							
LINDLEY ST								
PERSHING AVE								
POWELL ST	625							20
RIDGE CT	5							
WOODWARD AVE								
	2100	20	210	240	187	266	8778	930

SCHEDULE OF QUANTITIES

2013 RESURFACING (A)  
 SCHEDULE OF QUANTITIES

STREET	WH. PAVT. MARK. WH. PAVT. MARK. WH. PAVT. MARK. THERMO MARK			
	LINE 6" (LF)	LINE 12" (LF)	LINE 24" (LF)	LET & SYM (SF)
41ST ST			37	
59TH ST	686	324	208	182
61ST ST		72	13	
67TH PL			14	
68TH PL				
BARRETT ST				
BELLE AIRE LN		60	15	
BROOKSIDE LN			14	
CHASE AVE				
COMMERCE DR				
DUCHESS CT				
HIGHLAND AVE			36	
HILLCREST RD				
LINDLEY ST			36	
PERSHING AVE			13	
POWELL ST			28	
RIDGE CT				
WOODWARD AVE			14	
	686	456	428	182

SCHEDULE OF QUANTITIES

**V. BID and CONTRACT FORM (Village)**

**\*\*\*THIS BID WHEN ACCEPTED AND SIGNED BY AN AUTHORIZED SIGNATORY OF THE VILLAGE OF DOWNERS GROVE SHALL BECOME A CONTRACT BINDING UPON BOTH PARTIES.**

**Entire Form Must Be Completed If a Submitted Bid Is To Be Considered For Award**

**BIDDER:**

Central Blacktop Co., Inc.

3-18-2013

Company Name

Date

6160 S. East Ave., P.O. Box 2080

Estimating@centralblacktop.com

Street Address of Company

E-mail Address

LaGrange, IL 60525

Diane Forbus

City, State, Zip

Contact Name (Print)

708-482-9660

708-602-9660

Business Phone

24-Hour Telephone

708-482-9676

Business Fax

Signature of Officer, Partner or Sole Proprietor

James H. Loukota

ATTEST: if a Corporation

Print Name & Title

Signature of Corporation Secretary

We hereby agree to furnish the Village of Downers Grove all necessary materials, equipment, labor, etc. to complete the project by August 2, 2013 in accordance with the provisions, instructions and specifications for the unit prices shown on the Schedule of Prices.

**VILLAGE OF DOWNERS GROVE:**

**ATTEST:**

Authorized Signature

Village Clerk

Title

Date

Date

In compliance with the specifications, the above-signed offers and agrees, if this Bid is accepted within 90 calendar days from the date of opening, to furnish any or all of the services upon which prices are quoted, at the price set opposite each item, delivered at the designated point within the time specified above.

**V. BID and CONTRACT FORM (Contractor)**

**\*\*\*THIS BID WHEN ACCEPTED AND SIGNED BY AN AUTHORIZED SIGNATORY OF THE VILLAGE OF DOWNERS GROVE SHALL BECOME A CONTRACT BINDING UPON BOTH PARTIES.**

**Entire Form Must Be Completed If a Submitted Bid Is To Be Considered For Award**

**BIDDER:**

Central Blacktop Co., Inc.

Company Name

3-18-2013

Date

6160 S. East Ave., P.O. Box. 2080

Street Address of Company

Estimating@centralblacktop.com

E-mail Address

LaGrange, IL 60525

City, State, Zip

Diane Forbus

Contact Name (Print)

708-482-9660

Business Phone

708-602-9660

24-Hour Telephone

708-482-9676

Business Fax

Signature of Officer, Partner or Sole Proprietor

James H. Loukota

Print Name & Title

ATTEST: if a Corporation

Signature of Corporation Secretary

We hereby agree to furnish the Village of Downers Grove all necessary materials, equipment, labor, etc. to complete the project by August 2, 2013 in accordance with the provisions, instructions and specifications for the unit prices shown on the Schedule of Prices.

**VILLAGE OF DOWNERS GROVE:**

**ATTEST:**

Authorized Signature

Village Clerk

Title

Date

Date

In compliance with the specifications, the above-signed offers and agrees, if this Bid is accepted within 90 calendar days from the date of opening, to furnish any or all of the services upon which prices are quoted, at the price set opposite each item, delivered at the designated point within the time specified above.

**SCHEDULE OF PRICES:**

VILLAGE OF DOWNERS GROVE 2013 RESURFACING (A), BID #ST004A- 2013
--

ITEM NO.	ITEM	QUANTITY	UNIT	UNIT PRICE	TOTAL COST
1	Hot-Mix Asphalt Surface Course, Mix D, N50	6052	Ton	67.50	408,510.00
2	Leveling Binder (Machine Method), N50	2997	Ton	72.50	217,282.50
3	Bituminous Materials (Prime Coat)	10394	Gal.	0.01	103.94
4	Aggregate (Prime Coat)	139	Ton	0.01	1.39
5	Class D Patches, Type IV, 4"	16515	S.Y.	22.00	363,330.00
6	Class D Patches, 4" Special	873	S.Y.	25.00	21,825.00
7	Class D Patches, Type IV, 6"	640	S.Y.	32.00	20,480.00
8	Class D Patches, 6" Special	121	S.Y.	36.00	4,356.00
9	Pavement Removal & HMA Replacement, 8" Special	79	S.Y.	51.00	4,029.00
10	Porous Granular Embankment, Special	649	C.Y.	25.00	16,225.00
11	Additional Hauling Surcharge, Non-Hazardous Special Waste	21	Load	500.00	10,500.00
12	Combination Concrete Curb & Gutter Removal	13900	L.F.	4.00	55,600.00
13	Combination Concrete Curb & Gutter, Type B-4.12	2541	L.F.	13.00	33,033.00
14	Combination Concrete Curb & Gutter, Type M-6.12	2180	L.F.	13.50	29,430.00
15	Combination Concrete Curb & Gutter, Type B-6.12	7949	L.F.	14.00	111,286.00
16	Combination Concrete Curb & Gutter, Type B-6.12 Reinforced	787	L.F.	16.00	12,592.00
17	Combination Concrete Curb & Gutter, Type B-6.18	443	L.F.	20.00	8,860.00
18	Manhole to be Adjusted	49	EA.	318.00	15,582.00
19	Manhole to be Adjusted, Special	17	EA.	528.00	8,976.00
20	Manhole to be AdjustedW/ New Ty 1 Fr & CL	1	EA.	550.00	550.00

Village of Downers Grove – 2013 Resurfacing (A)

21	MH to be Reconstructed	1	EA.	870.00	870.00
22	Inlet to be Adjusted	21	EA.	283.00	5,943.00
23	Inlet to be Adjusted W/ New Ty 3 Fr. & Grate	25	EA.	592.00	14,800.00
24	Inlet to be Adjusted W/ New Ty 3 V Fr. & Grate	6	EA.	595.00	3,570.00
25	Inlet to be Reconstructed W/ New Ty 3 Fr & Grate	4	EA.	630.00	2,520.00
26	Inlet, Type A, 24" W/ New Ty 3 Fr. & Grate	3	EA.	920.00	2,760.00
27	Inlet, Type B, 36" W/ New Ty 3 Fr. & Grate	1	EA.	1,450.00	1,450.00
28	Storm Sewer, Type 1, DIP, 6"	30	LF.	82.35	2,470.50
29	Inlet Filters	11	EA.	150.00	1,650.00
30	Inlet Filters Cleaning	11	EA.	40.00	440.00
31	Hot-Mix Asphalt Surface Removal, 1.75"	26460	S.Y.	1.75	46,305.00
32	Hot-Mix Asphalt Surface Removal, 2.0"	35835	S.Y.	1.90	68,086.50
33	Hot-Mix Asphalt Surface Removal, 2.25"	565	S.Y.	2.00	1,130.00
34	Hot-Mix Asphalt Surface Removal, 2.5"	4513	S.Y.	2.30	10,379.90
35	Hot-Mix Asphalt Surface Removal, Variable Depth, 1.5" to 2.5"	2207	S.Y.	1.90	4,193.30
36	Mixture For Cracks, Joints & Flangeways	10	Ton	300.00	3,000.00
37	Portland Cement Concrete Sidewalk Removal	20004	S.F.	1.00	20,004.00
38	Portland Cement Concrete Sidewalk, 5"	17439	S.F.	4.00	69,756.00
39	Portland Cement Concrete Sidewalk, 6"	1597	S.F.	4.50	7,186.50
40	Portland Cement Concrete Sidewalk, 8"	181	S.F.	5.00	905.00
41	Detectable Warnings	1024	S.F.	28.00	28,672.00
42	Decorative Paver Driveway Removal & Replacement	58	S.Y.	65.00	3,770.00
43	Decorative Paver Sidewalk Removal & Replacement	1	S.Y.	65.00	65.00
44	Aggregate Shoulders, Type B	689	Ton	35.00	24,115.00

Village of Downers Grove – 2013 Resurfacing (A)

45	Parkway Restoration, Salt Tolerant, Special	7883	S.Y.	7.50	59,122.50
46	Supplemental Watering	12	Unit	140.00	1,680.00
47	Temporary Ramp, Hot-Mix Asphalt	22	S.Y.	30.00	660.00
48	Tree Root Pruning	2	EA.	200.00	400.00
49	Hot-Mix Asphalt Driveway Removal	947	S.Y.	13.00	12,311.00
50	Hot-Mix Asphalt Driveway Pavement, 3"	631	S.Y.	23.00	14,513.00
51	Hot-Mix Asphalt Driveway Pavement, 8"	316	S.Y.	38.00	12,008.00
52	Portland Cement Concrete Driveway Removal	2120	S.Y.	10.00	21,200.00
53	Portland Cement Concrete Driveway Pavement, 6"	2100	S.Y.	40.00	84,000.00
54	Portland Cement Concrete Driveway Pavement, 8"	20	S.Y.	42.00	840.00
55	Detector Loop, Type 1	210	L.F.	19.00	3,990.00
56	Short Term Pavement Marking, 4"	240	L.F.	2.00	480.00
57	Temporary Pavement Marking, Letters & Symbols	187	S.F.	2.00	374.00
58	Work Zone Pavement Marking, Removal	266	S.F.	2.00	532.00
59	Thermoplastic Pavement Marking Line, 4" Yellow	8778	L.F.	0.50	4,389.00
60	Thermoplastic Pavement Marking Line, 4" White	930	L.F.	0.50	465.00
61	Thermoplastic Pavement Marking Line, 6" White	686	L.F.	0.70	480.20
62	Thermoplastic Pavement Marking Line, 12" White	456	L.F.	1.40	638.40
63	Thermoplastic Pavement Marking Line, 24" White	428	L.F.	3.75	1,605.00
64	Thermoplastic Pavement Marking, Letters & Symbols	182	S.F.	4.00	728.00
65	Erosion, Sedimentation & Dust Control	1	L.S.	2,000.00	2,000.00
66	Construction Staking	1	L.S.	500.00	500.00
67	Traffic Control, Maintenance of Traffic, Detours	1	L.S.	29,000.00	29,000.00

TOTAL BID → \$1,918,509.63

**BIDDER'S CERTIFICATION (page 1 of 3)**

With regard to 2013 Resurfacing (A), Bidder Central Blaektop Co., Inc.  
(Name of Project) (Name of Bidder)

hereby certifies the following:

1. Bidder is not barred from bidding this Contract as a result of violations of Section 720 ILCS 5/33E-3 (Bid Rigging) or 720 ILCS 5/33E-4 (Bid-Rotating);
2. Bidder certifies that it has a written sexual harassment policy in place and full compliance with 775 ILCS 5/2-105(A)(4);
3. Bidder certifies that not less than the prevailing rate of wages as determined by the Village of Downers Grove, DuPage County or the Illinois Department of Labor shall be paid to all laborers, workers and mechanics performing work for the Village of Downers Grove. All bonds shall include a provision as will guarantee the faithful performance of such prevailing wage clause. Bidder agrees to comply with the Illinois Prevailing Wage Act, 820 ILCS 130/1 *et seq.*, for all work completed. Bidder agrees to pay the prevailing wage and require that all of its subcontractors pay prevailing wage to any laborers, workers or mechanics who perform work pursuant to this Contract or related subcontract. Bidder and each subcontractor shall keep or cause to be kept an accurate record of names, occupations and actual wages paid to each laborer, workman and mechanic employed by the Bidder in connection with the contract. This record shall be sent to the Village on a monthly basis along with the invoice and shall be open to inspection at all reasonable hours by any representative of the Village or the Illinois Department of Labor and must be preserved for four (4) years following completion of the contract. Bidder certifies that Bidder and any subcontractors working on the project are aware that filing false payroll records is a Class A misdemeanor and that the monetary penalties for violations are to be paid pursuant to law by the Bidder, contractor and subcontractor. The Village shall not be liable for any underpayments. If applicable: Since this is a contract for a fixed public works project, as defined in 820 ILCS 130/2, Contractor agrees to post at the job site in an easily accessible place, the prevailing wages for each craft or type of worker or mechanic needed to execute the contract or work to be performed;
4. Bidder certifies that it is in full compliance with the Federal Highway Administrative Rules on Controlled Substances and Alcohol Use and Testing, 49 C.F.R. Parts 40 and 382 and that all employee drivers are currently participating in a drug and alcohol testing program pursuant to the Rules;
5. Bidder further certifies that it is not delinquent in the payment of any tax administered by the Department of Revenue, or that Bidder is contesting its liability for the tax delinquency or the amount of a tax delinquency in accordance with the procedures established by the appropriate Revenue Act. Bidder further certifies that if it owes any tax payment(s) to the Department of Revenue, Bidder has entered into an agreement with the Department of Revenue for the payment of all such taxes that are due, and Bidder is in compliance with the agreement.

**BIDDER'S CERTIFICATION (page 2 of 3)**

BY: \_\_\_\_\_  
Bidder's Authorized Agent

3 6 - 2 4 4 7 4 1 6

**FEDERAL TAXPAYER IDENTIFICATION NUMBER**

or \_\_\_\_\_  
Social Security Number

Subscribed and sworn to before me  
this 18th day of March, 2013.

*(Signature)*  
Notary Public "OFFICIAL SEAL"  
DIANE J. VAVREK  
Notary Public, State of Illinois  
My Commission Expires 05/18/16

(Fill Out Applicable Paragraph Below)

**(a) Corporation**

The Bidder is a corporation organized and existing under the laws of the State of Illinois, which operates under the Legal name of Central Blacktop Co., Inc., and the full names of its Officers are as follows:

President: James H. Loukota

Secretary: Joseph E. Benson

Treasurer: \_\_\_\_\_

and it does have a corporate seal. (In the event that this bid is executed by other than the President, attach hereto a certified copy of that section of Corporate By-Laws or other authorization by the Corporation which permits the person to execute the offer for the corporation.)

**(b) Partnership**

Signatures and Addresses of All Members of Partnership:

\_\_\_\_\_  
\_\_\_\_\_  
\_\_\_\_\_  
\_\_\_\_\_

**BIDDER'S CERTIFICATION (page 3 of 3)**

The partnership does business under the legal name of: \_\_\_\_\_  
which name is registered with the office of \_\_\_\_\_ in the state of \_\_\_\_\_

**(c) Sole Proprietor**

The Bidder is a Sole Proprietor whose full name is: \_\_\_\_\_  
and if operating under a trade name, said trade name is: \_\_\_\_\_  
which name is registered with the office of \_\_\_\_\_ in the state of \_\_\_\_\_

6. Are you willing to comply with the Village's insurance requirements within 13 days of the award of the contract? Yes

INSURER'S NAME: Agent-Weible & Cahill

AGENT: Bill Cahill

Street Address: 2300 Cabot Dr. Suite 100

City, State, Zip Code: Lisle, IL 60532

Telephone Number: 630-245-4600

I/We hereby affirm that the above certifications are true and accurate and that I/we have read and understand them.

Print Name of Company: Central Blacktop Co., Inc.

Print Name and Title of Authorizing Signature: James H. Loukota

Signature: \_\_\_\_\_

Date: 3-18-2013

**MUNICIPAL REFERENCE LIST**

Municipality: Village of Downers Grove  
 Address: 5101 Walnut Ave, Downers Grove, IL 60515  
 Contact Name: Scott Barr Phone #: \_\_\_\_\_  
 Name of Project: 2012 Resurfacing (A)  
 Contract Value: \$2,100,000 Date of Completion: 2012-Fall

Municipality: Village of Stibney - Street Rehab Ph. 6  
 Address: 6533 W. Peasling Rd., Stibney, IL 60402  
 Contact Name: Jim Seery - Frank Novotny Phone #: 630-987-8640  
 Name of Project: Street Rehab Ph. 6  
 Contract Value: \$400,000 Date of Completion: 2012-Fall

Municipality: Village of Westmont  
 Address: 39 E. Burlington Ave, Westmont, IL 60559  
 Contact Name: Ronald Noriega Phone #: 630-981-6295  
 Name of Project: 2012 MFT Resurfacing Project  
 Contract Value: \$730,000 Date of Completion: 2012-Fall

Municipality: Village of Forest Park  
 Address: 517 Des Plaines Ave, Forest Park, IL 60130  
 Contact Name: Chris. Burke Aug - Jim Amelio Phone #: 847-652-1343  
 Name of Project: Industrial Police Rehab  
 Contract Value: \$460,000 Date of Completion: 2011-Fall

Municipality: Village of Hodgkin  
 Address: 8590 Lyon Street, Hodgkin, IL 60525  
 Contact Name: Huer + asso. Phone #: 708-482-1000  
 Name of Project: Continental Toyota of Hodgkin  
 Contract Value: \$1,400,000 Date of Completion: 2009-Summer

**SUBCONTRACTORS LIST**

The Bidder hereby states the following items of work will not be performed by its organization. (List items to be subcontracted as well as the names, addresses and phone numbers of the subcontractors.)

1) Schroeder + Schroeder Type of Work Concrete

Addr: 7306 Central Park City Spokane State IL Zip 60076

2) Superior Road Striping Type of Work Striping

Addr: 1967 Cornell Ct City Milrose Pk. State IL Zip 60160

3) Hawk Enterprises Type of Work Ret. Loop

Addr: 1850 E. North Street City Grown Point State IN Zip 46307

4) American Topsoil Type of Work Landscaping

Addr: P.O. Box 1856 City Milrose Pk State IL Zip 60161

5) Roy Edwards Type of Work Sewer

Addr: 827 Powell ave. City Joliet State IL Zip 60483

6) \_\_\_\_\_ Type of Work \_\_\_\_\_

Addr: \_\_\_\_\_ City \_\_\_\_\_ State \_\_\_\_\_ Zip \_\_\_\_\_

7) \_\_\_\_\_ Type of Work \_\_\_\_\_

Addr: \_\_\_\_\_ City \_\_\_\_\_ State \_\_\_\_\_ Zip \_\_\_\_\_

8) \_\_\_\_\_ Type of Work \_\_\_\_\_

Addr: \_\_\_\_\_ City \_\_\_\_\_ State \_\_\_\_\_ Zip \_\_\_\_\_



**VENDOR W-9 REQUEST FORM**

The law requires that we maintain accurate taxpayer identification numbers for all individuals and partnerships to whom we make payments, because we are required to report to the I.R.S all payments of \$600 or more annually. We also follow the I.R.S. recommendation that this information be maintained for all payees including corporations.

Please complete the following substitute W-9 letter to assist us in meeting our I.R.S. reporting requirements. The information below will be used to determine whether we are required to send you a Form 1099. Please respond as soon as possible, as failure to do so will delay our payments.

**BUSINESS (PLEASE PRINT OR TYPE):**

NAME: Central Blacktop Co., Inc.  
ADDRESS: 6160 S. East Ave., P.O. Box 2080  
CITY: LaGrange  
STATE: Illinois  
ZIP: 60525  
PHONE: 708-482-9660 FAX: 708-482-9676  
TAX ID #(TIN): 36-2447416

(If you are supplying a social security number, please give your full name)

**REMIT TO ADDRESS (IF DIFFERENT FROM ABOVE):**

NAME: \_\_\_\_\_  
ADDRESS: \_\_\_\_\_  
CITY: \_\_\_\_\_  
STATE: \_\_\_\_\_ ZIP: \_\_\_\_\_

**TYPE OF ENTITY (CIRCLE ONE):**

- Individual
- Sole Proprietor
- Partnership
- Medical
- Charitable/Nonprofit
- Limited Liability Company –Individual/Sole Proprietor
- Limited Liability Company-Partnership
- Limited Liability Company-Corporation
- Corporation
- Government Agency

SIGNATURE: [Signature] DATE: 3-18-2013

**Apprenticeship and Training Certification**

(Does not apply to federal aid projects. Applicable only to maintenance and construction projects that use Motor Fuel Tax funds or state grant monies.)

Name of Bidder: Central Blacktop Co., Inc.

In accordance with the provisions of Section 30-22 (6) of the Illinois Procurement Code, the Bidder certifies that it is a participant, either as an individual or as part of a group program, in the approved apprenticeship and training programs applicable to each type of work or craft that the bidder will perform with its own forces. The Bidder further certifies for work that will be performed by subcontract that each of its subcontractors submitted for approval either (a) is, at the time of such bid, participating in an approved, applicable apprenticeship and training program; or (b) will, prior to commencement of performance of work pursuant to this Contract, begin participation in an approved apprenticeship and training program applicable to the work of the subcontract. The Illinois Department of Labor, at any time before or after award, may require the production of a copy of each applicable Certificate of Registration issued by the United States Department of Labor evidencing such participation by the contractor and any or all of its subcontractors. Applicable apprenticeship and training programs are those that have been approved and registered with the United States Department of Labor. The Bidder shall list in the space below, the official name of the program sponsor holding the Certificate of Registration for all of the types of work or crafts in which the Bidder is a participant and that will be performed with the Bidder's forces. Types of work or craft work that will be subcontracted shall be included and listed as subcontract work. The list shall also indicate any type of work or craft job category that does not have an applicable apprenticeship or training program. **The Bidder is responsible for making a complete report and shall make certain that each type of work or craft job category that will be utilized on the project is accounted for and listed. Return this with the Bid.**

Operating Engineers Local 150 Apprenticeship & Training

\*See Attached

The requirements of this certification and disclosure are a material part of the Contract, and the Contractor shall require this certification provision to be included in all approved subcontracts. In order to fulfill this requirement, it shall not be necessary that an applicable program sponsor be currently taking or that it will take applications for apprenticeship, training or employment during the performance of the work of this Contract.

Print Name and Title of Authorizing Signature: James H. Loukota

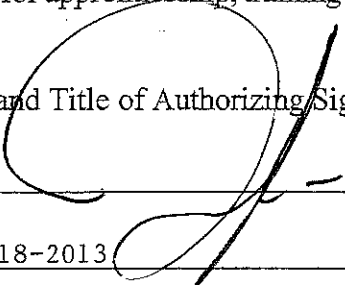
Signature: 

Date: 3-18-2013

**BUY AMERICA CERTIFICATION**

**Certification requirement for procurement of steel, iron, or manufactured products when Federal funds (Grant Agreement or Cooperative Agreement) are used.**

*Instructions:*

*Bidder to complete the Buy America Certification listed below. Bidder shall certify EITHER COMPLIANCE OR NON-COMPLIANCE (not both). This Certification MUST BE submitted with the Bidder's bid response. Special Note: Make sure you have signed only one of the above statements – either Compliance OR Non-Compliance (not both).*

**Certificate of Compliance**

The bidder or offeror hereby certifies that it will meet the requirements of 49 U.S.C. 5323(j)(1), as amended, and the applicable regulations in 49 CFR Part 661.

Signature \_\_\_\_\_

Company Name Central Blacktop Co., Inc.

Title President

Date 3-18-2013

**Certificate of Non-Compliance**

The bidder or offeror hereby certifies that it cannot comply with the requirements of 49 U.S.C. 5323(j)(1), as amended, and 49 C.F.R. 661, but it may qualify for an exception pursuant to 49 U.S.C. 5323(j)(2)(A), 5323(j)(2)(B), or 5323(j)(2)(D), and 49 C.F.R. 661.7.

Signature \_\_\_\_\_

Company Name \_\_\_\_\_

Title \_\_\_\_\_

Date \_\_\_\_\_

**AFTER THIS CERTIFICATE HAS BEEN EXECUTED, A BIDDER MAY NOT SEEK A WAIVER.**

Note: The U.S./Canadian Free Trade Agreement does not supersede the Buy America requirement.

**Suspension or Debarment Certificate**

Non-Federal entities are prohibited from contracting with or making sub-awards under covered transactions to parties that are suspended or debarred or whose principals are suspended or debarred. Covered transactions include procurement for goods or services equal to or in excess of \$100,000.00. Contractors receiving individual awards for \$100,000.00 or more and all sub-recipients must certify that the organization and its principals are not suspended or debarred.

By submitting this offer and signing this certificate, the Bidder certifies to the best of its knowledge and belief, that the company and its principals:

1. Are not presently debarred, suspended, proposed for debarment, declared ineligible or voluntarily excluded from covered transactions by any federal, state or local governmental entity, department or agency;
2. Have not within a three-year period preceding this Bid been convicted of or had a civil judgment rendered against them for commission of fraud or a criminal offense in connection with obtaining, attempting to obtain, or performing a public (Federal, State or local) transaction or contract under a public transaction, or convicted of or had a civil judgment against them for a violation of Federal or state antitrust statutes or commission of embezzlement, theft, forgery, bribery, falsification or destruction of records, making false statements, or receiving stolen property;
3. Are not presently indicted for or otherwise criminally or civilly charged by a governmental entity (Federal, State, or local) with commission of any of the offenses enumerated in paragraph (2) of this certification; and
4. Have not within a three-year period preceding this application/proposal/contract had one or more public transactions (Federal, State or local) terminated for cause or default.

If the Bidder is unable to certify to any of the statements in this certification, Bidder shall attach an explanation to this certification.

Company Name: Central Blacktop Co., Inc.

Address: 6160 S. East Ave., P.O. Box 2080

City: LaGrange Zip Code: 60525

Telephone: (708) 482-9660 Fax Number: (708) 482-9676

E-mail Address: Estimating@centralblacktop.com

Authorized Company Signature: 

Print Signature Name: James H. Loukota Title of Official: President

Date: 5-18-2013



**BID SUBMITTAL CHECKLIST**

Each Bidder's Bid Package must be submitted with all requisite forms properly completed, and all documentation included. The following list is not all-inclusive, but is designed to facilitate a good, competitive bidding environment.

1.  Instructions to Bidders read and understood. Any questions must be asked according to the instructions.
2.  Cover sheet filled-in
3.  Bid Form copies filled-in. All copies must have original signatures and seals on them.
4.  Bid Bond or cashier's check enclosed with bid package.
5.  Schedule of Prices completed. Check your math!
6.  Bidder Certifications signed and sealed.
7.  Letter from Surety ensuring issuance of Performance and Labor Bonds.
8.  Letter from Insurance Agent or Carrier ensuring issuance of required job coverage.
9.  Municipal Reference List completed.
10.  Vendor request form W-9 completed.
11.  Affidavit (IDOT Form BC-57, or similar).
12.  Bid package properly sealed and labeled before delivery. If sending by mail or messenger, enclose in a second outer envelope or container. Project plan sheets do not have to be included with the bid package.

**United States Department of Labor**

**Office of Apprenticeship Training, Employer and Labor Services  
Bureau of Apprenticeship and Training**

**Certificate of Registration**

**Operating Engineers Local #150  
Plainfield, Illinois**

**For the Trade of Operating Engineer**

**Registered as part of the National Apprenticeship Program  
in accordance with the basic standards of apprenticeship  
established by the Secretary of Labor**

November 9, 2002  
Date

22 008780173  
Registration No.



*R. J. Chad*  
Secretary of Labor

*[Signature]*  
Director, Apprenticeship Training, Employer and Labor Services

**UNITED STATES DEPARTMENT OF LABOR**

**Office of Apprenticeship Training, Employer and Labor Services**  
**Bureau of Apprenticeship and Training**  
**Certificate of Registration**

**INTERNATIONAL BROTHERHOOD OF TEAMSTERS**  
**Joint Council No. 25 Training Fund**  
**For the Trade of Construction Driver**

*Registered as part of the National Apprenticeship Program  
in accordance with the basic standards of apprenticeship  
established by the Secretary of Labor*

June 28, 2005

Date

IL015050004

Registration DC

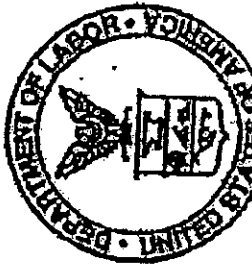

*D. J. Chad*  
Secretary of Labor

*Anthony S. ...*

# United States Department of Labor



## Bureau of Apprenticeship and Training Certificate of Registration

CEMENT MASONS' AREA JOINT APPRENTICESHIP & CEMENT MASONS UNION LOC. NO. 502  
BELLWOOD, ILLINOIS

FOR THE TRADE OF: CEMENT MASON

*Registered as part of the National Apprenticeship Program  
in accordance with the basic standards of apprenticeship  
established by the Secretary of Labor*

REGISTERED: OCTOBER 17, 1945  
REVISED: DECEMBER 29, 1988  
Date

008-0816  
Registration No.

*Ann McLaughlin*

Secretary of Labor

*James D. Van Edd*

Director, Bureau of Apprenticeship and Training

# United States Department of Labor

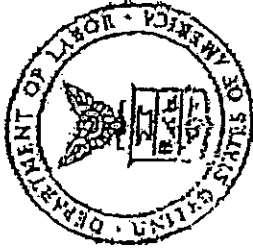

Bureau of Apprenticeship and Training

Certificate of Registration

*Chicago and Laborers' Training & Apprenticeship Program*  
*For the Trade of Construction Craft Laborer*

*Registered as part of the National Apprenticeship Program*  
*in accordance with the basic standards of apprenticeship*  
*established by the Secretary of Labor*

April 12, 1999

Date

11A17-0602

Registration No.

DOT # 869-463-580

*Robert M. Allen*

Secretary of Labor

*Anthony Swartz*  
Director, Bureau of Apprenticeship and Training

# WEIBLE CAHILL

March 18, 2013

Village of Downers Grove  
5101 Walnut Avenue  
Downers Grove IL 60515

RE: Central Blacktop Co, Inc

Project: Bid No: ST004A-2013: 2013 Resurfacing (A)

To Whom It May Concern:

Please be advised that we are the bonding agent for Central Blacktop Co, Inc. This contractor obtains their bonds through Continental Casualty Company, 333 South Wabash Ave., 41st Floor, Chicago IL 60604. As stated in the A.M. Best Rating Guide Continental Casualty Company has a rating of A XV.

Continental Casualty Company would be willing to entertain a performance and payment bond request on behalf of Central Blacktop Co, Inc. Both the surety and the contractor would issue the bond in 100% of the total contract price subject to review of the contract documents and financing of project.

This letter shall serve to verify that the information provided by Central Blacktop Co, Inc, in the pre-qualification form in regard to the surety and bonding information is correct. I trust that this information satisfies your inquiry. Should you require anything further, please do not hesitate to call.

Sincerely,

Weible & Cahill



Esther C. Jimenez  
Bond Administrator of Weible & Cahill

# WEIBLE CAHILL

March 11, 2013

Village of Downers Grove  
5101 Walnut Avenue  
Downers Grove, IL 60515

Re: Contractor: Central Blacktop Co, Inc  
Job: Bid No. ST004A-2013, 2013 Resurfacing (A)

Gentlemen:

Please be advised that we have reviewed the insurance requirements and are prepared to certify that the required policies are in effect or we will issue the equivalent coverage as set forth in the Contract Documents upon award of the captioned project to the bidder.

If you should have any questions, please contact the undersigned.

Sincerely yours,

Weible & Cahill

*Kim Sawicki*

Kim Sawicki



**Illinois Department of Transportation**

Bureau of Construction  
2300 South Dirksen Parkway/Room 322  
Springfield, Illinois 62764

**Affidavit of Availability**  
For the Letting of 3/8/2013

(Letting date)

Instructions: Complete this form by either typing or using black ink. "Authorization to Bid" will not be issued unless both sides of this form are completed in detail. Use additional forms as needed to list all work.

**Part I. Work Under Contract**

List below all work you have under contract as either a prime contractor or a subcontractor. It is required to include all pending low bids not yet awarded or rejected. In a joint venture, list only that portion of the work which is the responsibility of your company. The uncompleted dollar value is to be based upon the most recent engineer's or owners estimate, and must include work subcontracted to others. If no work is contracted, show NONE.

	211-024 71st St	212-019 Pasquirelli Dr	212-023 Harlem Ave	212-024 Joliet Rd	
Contract Number	63556	63579	60T14	60T48	
Contract With	Lorig Const	Alliance Contrs	IDOT	IDOT	
Estimated Completion Date	June 2013	Nov 2013	June 2013		
Total Contract Price	351,000.00	157,997.00	217,527.00	133,016.00	Accumulated Totals
Uncompleted Dollar Value if Firm is the Prime Contractor			217,527.00	133,016.00	350,543.00
Uncompleted Dollar Value if Firm is the Subcontractor	351,000.00	157,997.00			508,997.00
<b>Total Value of All Work</b>					<b>859,540.00</b>

**Part II. Awards Pending and Uncompleted Work to be done with your own forces.**

List below the uncompleted dollar value of work for each contract and awards pending to be completed with your own forces. All work subcontracted to others will be listed on the reverse of this form. In a joint venture, list only that portion of the work to be done by your company. If no work is contracted, show NONE.

					Accumulated Totals	
Earthwork			20,000.00	11,800.00	31,800.00	
Portland Cement Concrete Paving					0.00	
HMA Plant Mix		75,000.00	10,000.00		85,000.00	
HMA Paving	339,000.00	82,997.00	124,745.00	37,506.00	584,248.00	
Clean & Seal Cracks/Joints					0.00	
Aggregate Bases & Surfaces				4,050.00	4,050.00	
Highway, R.R. and Waterway Structures					0.00	
Drainage				11,229.00	11,229.00	
Electrical					0.00	
Cover and Seal Coats					0.00	
Concrete Construction					0.00	
Landscaping					0.00	
Fencing					0.00	
Guardrail					0.00	
Painting					0.00	
Signing					0.00	
Cold Milling, Planning & Rotomilling					0.00	
Demolition					0.00	
Pavement Markings (Paint)					0.00	
Other Construction (List)					0.00	
Grinding	12,000.00		25,000.00	5,400.00	42,400.00	
					0.00	
<b>Totals</b>	<b>351,000.00</b>	<b>157,997.00</b>	<b>179,745.00</b>	<b>69,985.00</b>	<b>0.00</b>	<b>758,727.00</b>

Disclosure of this information is **REQUIRED** to accomplish the statutory purpose as outlined in the "Illinois Procurement Code". Failure to comply will result in non-issuance of an "Authorization To Bid." This form has been approved by the State Forms Management Center.

**Part III. Work Subcontracted to Others**

For each contract described in Part I, list all the work you have subcontracted to others.

	1	2	3	4	5
Subcontractor	No Subs	No Subs	Carrera Conc	DNB Constr.	
Type of Work			Concrete	Concrete	
Subcontract Price			9,044.00	14,918.00	
Amount Uncompleted			9,044.00	14,918.00	
Subcontractor			Hawk Elec	DNB Constr.	
Type of Work			Det Loops	Drainage	
Subcontract Price			5,760.00	3,608.00	
Amount Uncompleted			5,760.00	3,608.00	
Subcontractor			Hwy Safety	Work Zone Safety	
Type of Work			Traffic Control	Traffic Control	
Subcontract Price			5,917.00	8,661.00	
Amount Uncompleted			5,917.00	8,661.00	
Subcontractor			Mark-It Corp	Nat. Power Rod	
Type of Work			Striping	Sewer Cleaning	
Subcontract Price			7,961.00	35,844.00	
Amount Uncompleted			7,961.00	35,844.00	
Subcontractor			Rula's Ent		
Type of Work			Drainage		
Subcontract Price			9,100.00		
Amount Uncompleted			9,100.00		
Subcontractor					
Type of Work					
Subcontract Price					
Amount Uncompleted					
Subcontractor					
Type of Work					
Subcontract Price					
Amount Uncompleted					
<b>Total Uncompleted</b>	<b>0.00</b>	<b>0.00</b>	<b>37,782.00</b>	<b>63,031.00</b>	<b>0.00</b>

I, being duly sworn, do hereby declare this affidavit is a true and correct statement relating to ALL uncompleted contracts of the undersigned for Federal, State, County, City and private work, including ALL subcontract work, ALL pending low bids not yet awarded or rejected and ALL estimated completion dates

Subscribed and sworn to before me

\_\_\_\_\_  
 Notary Public  
 My commission expires: \_\_\_\_\_

(Notary Seal)

Type or Print Name \_\_\_\_\_  
 Officer or Director \_\_\_\_\_ Title \_\_\_\_\_  
 Signed \_\_\_\_\_  
 Company \_\_\_\_\_  
 Address \_\_\_\_\_



**Illinois Department  
of Transportation**

Bureau of Construction  
2300 South Dirksen Parkway/Room 322  
Springfield, Illinois 62764

**Affidavit of Availability  
For the Letting of 3/8/2013**

(Letting date)

Instructions: Complete this form by either typing or using black ink.  
"Authorization to Bid" will not be issued unless both sides of this form are  
completed in detail. Use additional forms as needed to list all work.

**Part I. Work Under Contract**

List below all work you have under contract as either a prime contractor or a subcontractor. It is required to include all pending low bids not yet awarded or rejected. In a joint venture, list only that portion of the work which is the responsibility of your company. The uncompleted dollar value is to be based upon the most recent engineer's or owners estimate, and must include work subcontracted to others. If no work is contracted, show NONE.

	213-001	213-002			Awards Pending	
Contract Number	63736					
Contract With	IDOT	City of Darien				
Estimated Completion Date	Aug 2013	Aug 2013				
Total Contract Price	1,042,205.00	1,053,209.00				Accumulated Totals
Uncompleted Dollar Value if Firm is the Prime Contractor	1,042,205.00	1,053,209.00				2,445,957.00
Uncompleted Dollar Value if Firm is the Subcontractor						508,997.00
<b>Total Value of All Work</b>						<b>2,954,954.00</b>

**Part II. Awards Pending and Uncompleted Work to be done with your own forces.**

List below the uncompleted dollar value of work for each contract and awards pending to be completed with your own forces. All work subcontracted to others will be listed on the reverse of this form. In a joint venture, list only that portion of the work to be done by your company. If no work is contracted, show NONE.

						Accumulated Totals
Earthwork		35,000.00				66,800.00
Portland Cement Concrete Paving						0.00
HMA Plant Mix		35,000.00				120,000.00
HMA Paving	574,239.00	713,699.00				1,872,186.00
Clean & Seal Cracks/Joints						0.00
Aggregate Bases & Surfaces						4,050.00
Highway,R.R. and Waterway Structures						0.00
Drainage						11,229.00
Electrical						0.00
Cover and Seal Coats						0.00
Concrete Construction	30,000.00					30,000.00
Landscaping						0.00
Fencing						0.00
Guardrail						0.00
Painting						0.00
Signing						0.00
Cold Milling, Planning & Rotomilling						0.00
Demolition						0.00
Pavement Markings (Paint)						0.00
Other Construction (List)						0.00
Grinding	30,000.00	150,000.00				222,400.00
						0.00
<b>Totals</b>	<b>634,239.00</b>	<b>933,699.00</b>	<b>0.00</b>	<b>0.00</b>	<b>0.00</b>	<b>2,326,665.00</b>

Disclosure of this information is **REQUIRED** to accomplish the statutory purpose as outlined in the "Illinois Procurement Code". Failure to comply will result in non-issuance of an "Authorization To Bid." This form has been approved by the State Forms Management Center.

**Part III. Work Subcontracted to Others**

For each contract described in Part I, list all the work you have subcontracted to others.

	1	2	3	4	Awards Pending
Subcontractor	Azteca Power	Geomat			No Subs
Type of Work	Conc&Sewer	Petromat			
Subcontract Price	350,557.00	111,010.00			
Amount Uncompleted	350,557.00	111,010.00			
Subcontractor	Hawk Elec	DNB			
Type of Work	Detector Loops	Structure Adj			
Subcontract Price	10,194.00	8,500.00			
Amount Uncompleted	10,194.00	8,500.00			
Subcontractor	Precision Pavt Marking				
Type of Work	Striping				
Subcontract Price	26,895.00				
Amount Uncompleted	26,895.00				
Subcontractor	Hwy Safety				
Type of Work	Traffic Control				
Subcontract Price	20,320.00				
Amount Uncompleted	20,320.00				
Subcontractor					
Type of Work					
Subcontract Price					
Amount Uncompleted					
Subcontractor					
Type of Work					
Subcontract Price					
Amount Uncompleted					
Subcontractor					
Type of Work					
Subcontract Price					
Amount Uncompleted					
<b>Total Uncompleted</b>	<b>407,966.00</b>	<b>119,510.00</b>	<b>0.00</b>		<b>0.00</b>

I, being duly sworn, do hereby declare this affidavit is a true and correct statement relating to ALL uncompleted contracts of the undersigned for Federal, State, County, City and private work, including ALL subcontract work, ALL pending low bids not yet awarded or rejected and ALL estimated completion dates

Subscribed and sworn to before me

**this 18th day of March, 2013**

*Diane J. Vavrek*  
Notary Public

Type or Print Name **James H. Loukota, President**  
Officer or Director

Title

Signed

My commission expires

(Notary Seal)

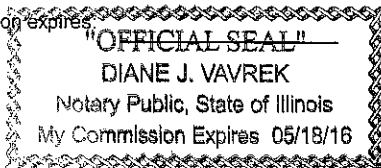

Company **Central Blacktop Co., Inc.**

Address **6160 S. East Ave., P.O. Box 2010**

**LaGrange, IL 6055**



STATE OF Illinois  
COUNTY OF Will

I, Kimberly R. Holmes Notary Public of Will County,  
in the State of Illinois, do hereby certify that Esther C. Jimenez  
Attorney-in-Fact, of the Continental Casualty Company  
who is personally known to me to be the same person whose name is  
subscribed to the foregoing instrument, appeared before me this day in person, and  
acknowledged that he signed, sealed and delivered said instrument, for and on behalf of the  
Continental Casualty Company

for the uses and purposes therein set forth.

Given under my hand and notarial seal at my office in the City of Liste  
in said County, this 18th day of March A.D., 2013

*Kimberly R. Holmes*  
Notary Public Kimberly R. Holmes

My Commission expires: February 11, 2014

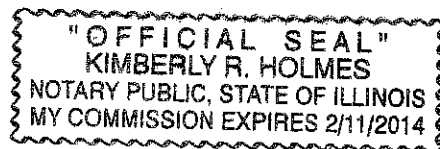

POWER OF ATTORNEY APPOINTING INDIVIDUAL ATTORNEY-IN-FACT

Know All Men By These Presents, That Continental Casualty Company, an Illinois insurance company, National Fire Insurance Company of Hartford, an Illinois insurance company, and American Casualty Company of Reading, Pennsylvania, a Pennsylvania insurance company (herein called "the CNA Companies"), are duly organized and existing insurance companies having their principal offices in the City of Chicago, and State of Illinois, and that they do by virtue of the signatures and seals herein affixed hereby make, constitute and appoint

Esther C. Jimenez , Individually

of Lisle, IL their true and lawful Attorney(s)-in-Fact with full power and authority hereby conferred to sign, seal and execute for and on their behalf bonds, undertakings and other obligatory instruments of similar nature

- In Unlimited Amounts -

Surety Bond Number: Bid Bond
Principal: Central Blacktop Co., Inc.
Obligee: Village of Downers Grove

and to bind them thereby as fully and to the same extent as if such instruments were signed by a duly authorized officer of their insurance companies and all the acts of said Attorney, pursuant to the authority hereby given is hereby ratified and confirmed.

This Power of Attorney is made and executed pursuant to and by authority of the By-Law and Resolutions, printed on the reverse hereof, duly adopted, as indicated, by the Boards of Directors of the insurance companies.

In Witness Whereof, the CNA Companies have caused these presents to be signed by their Vice President and their corporate seals to be hereto affixed on this 16th day of May, 2012.



Continental Casualty Company
National Fire Insurance Company of Hartford
American Casualty Company of Reading, Pennsylvania

Paul T. Bruffat
Vice President

State of South Dakota, County of Minnehaha, ss:

On this 16th day of May, 2012, before me personally came Paul T. Bruffat to me known, who, being by me duly sworn, did depose and say: that he resides in the City of Sioux Falls, State of South Dakota; that he is a Vice President of Continental Casualty Company, an Illinois insurance company, National Fire Insurance Company of Hartford, an Illinois insurance company, and American Casualty Company of Reading, Pennsylvania, a Pennsylvania insurance company described in and which executed the above instrument; that he knows the seals of said insurance companies; that the seals affixed to the said instrument are such corporate seals; that they were so affixed pursuant to authority given by the Boards of Directors of said insurance companies and that he signed his name thereto pursuant to like authority, and acknowledges same to be the act and deed of said insurance companies.

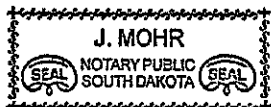

My Commission Expires June 23, 2015

J. Mohr
Notary Public

CERTIFICATE

I, D. Bult, Assistant Secretary of Continental Casualty Company, an Illinois insurance company, National Fire Insurance Company of Hartford, an Illinois insurance company, and American Casualty Company of Reading, Pennsylvania, a Pennsylvania insurance company do hereby certify that the Power of Attorney herein above set forth is still in force, and further certify that the By-Law and Resolution of the Board of Directors of the insurance companies printed on the reverse hereof is still in force. In testimony whereof I have hereunto subscribed my name and affixed the seal of the said insurance companies this 18th day of March, 2013.



Continental Casualty Company
National Fire Insurance Company of Hartford
American Casualty Company of Reading, Pennsylvania

D. Bult
Assistant Secretary

## Authorizing By-Laws and Resolutions

ADOPTED BY THE BOARD OF DIRECTORS OF CONTINENTAL CASUALTY COMPANY:

This Power of Attorney is made and executed pursuant to and by authority of the following resolution duly adopted by the Board of Directors of the Company at a meeting held on May 12, 1995:

"RESOLVED: That any Senior or Group Vice President may authorize an officer to sign specific documents, agreements and instruments on behalf of the Company provided that the name of such authorized officer and a description of the documents, agreements or instruments that such officer may sign will be provided in writing by the Senior or Group Vice President to the Secretary of the Company prior to such execution becoming effective."

This Power of Attorney is signed by Paul T. Bruflat, Vice President, who has been authorized pursuant to the above resolution to execute power of attorneys on behalf of Continental Casualty Company.

This Power of Attorney is signed and sealed by facsimile under and by the authority of the following Resolution adopted by the Board of Directors of the Company by unanimous written consent dated the 25<sup>th</sup> day of April, 2012:

"Whereas, the bylaws of the Company or specific resolution of the Board of Directors has authorized various officers (the "Authorized Officers") to execute various policies, bonds, undertakings and other obligatory instruments of like nature; and

Whereas, from time to time, the signature of the Authorized Officers, in addition to being provided in original, hard copy format, may be provided via facsimile or otherwise in an electronic format (collectively, "Electronic Signatures"); Now therefore be it resolved: that the Electronic Signature of any Authorized Officer shall be valid and binding on the Company."

ADOPTED BY THE BOARD OF DIRECTORS OF NATIONAL FIRE INSURANCE COMPANY OF HARTFORD:

This Power of Attorney is made and executed pursuant to and by authority of the following resolution duly adopted by the Board of Directors of the Company by unanimous written consent dated May 10, 1995:

"RESOLVED: That any Senior or Group Vice President may authorize an officer to sign specific documents, agreements and instruments on behalf of the Company provided that the name of such authorized officer and a description of the documents, agreements or instruments that such officer may sign will be provided in writing by the Senior or Group Vice President to the Secretary of the Company prior to such execution becoming effective."

This Power of Attorney is signed by Paul T. Bruflat, Vice President, who has been authorized pursuant to the above resolution to execute power of attorneys on behalf of National fire Insurance Company of Hartford.

This Power of Attorney is signed and sealed by facsimile under and by the authority of the following Resolution adopted by the Board of Directors of the Company by unanimous written consent dated the 25<sup>th</sup> day of April, 2012:

"Whereas, the bylaws of the Company or specific resolution of the Board of Directors has authorized various officers (the "Authorized Officers") to execute various policies, bonds, undertakings and other obligatory instruments of like nature; and

Whereas, from time to time, the signature of the Authorized Officers, in addition to being provided in original, hard copy format, may be provided via facsimile or otherwise in an electronic format (collectively, "Electronic Signatures"); Now therefore be it resolved: that the Electronic Signature of any Authorized Officer shall be valid and binding on the Company."

ADOPTED BY THE BOARD OF DIRECTORS OF AMERICAN CASUALTY COMPANY OF READING, PENNSYLVANIA:

This Power of Attorney is made and executed pursuant to and by authority of the following resolution duly adopted by the Board of Directors of the Company by unanimous written consent dated May 10, 1995:

"RESOLVED: That any Senior or Group Vice President may authorize an officer to sign specific documents, agreements and instruments on behalf of the Company provided that the name of such authorized officer and a description of the documents, agreements or instruments that such officer may sign will be provided in writing by the Senior or Group Vice President to the Secretary of the Company prior to such execution becoming effective."

This Power of Attorney is signed by Paul T. Bruflat, Vice President, who has been authorized pursuant to the above resolution to execute power of attorneys on behalf of American Casualty Company of Reading, Pennsylvania.

This Power of Attorney is signed and sealed by facsimile under and by the authority of the following Resolution adopted by the Board of Directors of the Company by unanimous written consent dated the 25<sup>th</sup> day of April, 2012:

"Whereas, the bylaws of the Company or specific resolution of the Board of Directors has authorized various officers (the "Authorized Officers") to execute various policies, bonds, undertakings and other obligatory instruments of like nature; and

Whereas, from time to time, the signature of the Authorized Officers, in addition to being provided in original, hard copy format, may be provided via facsimile or otherwise in an electronic format (collectively, "Electronic Signatures"); Now therefore be it resolved: that the Electronic Signature of any Authorized Officer shall be valid and binding on the Company."

**CAMPAIGN DISCLOSURE CERTIFICATE**

Any contractor, proposer, bidder or vendor who responds by submitting a bid or proposal to the Village of Downers Grove shall be required to submit with its bid submission, an executed Campaign Disclosure Certificate.

The Campaign Disclosure Certificate is required pursuant to the Village of Downers Grove Council Policy on Ethical Standards and is applicable to those campaign contributions made to any member of the Village Council.

Said Campaign Disclosure Certificate requires any individual or entity bidding to disclose campaign contributions, as defined in Section 9-1.4 of the Election Code (10 ILCS 5/9-1.4), made to current members of the Village Council within the five (5) year period preceding the date of the bid or proposal release.

By signing the bid documents, contractor/proposer/bidder/vendor agrees to refrain from making any campaign contributions as defined in Section 9-1.4 of the Election Code (10 ILCS 5/9-1.4) to any Village Council member and any challengers seeking to serve as a member of the Downers Grove Village Council.

Under penalty of perjury, I declare:

Bidder/vendor has not contributed to any elected Village position within the last five (5) years.

Joseph E. Benson Joseph E. Benson  
Signature Print Name

Bidder/vendor has contributed a campaign contribution to a current member of the Village Council within the last five (5) years.

Print the following information:

Name of Contributor: \_\_\_\_\_  
(company or individual)

To whom contribution was made: \_\_\_\_\_

Year contribution made: \_\_\_\_\_ Amount: \$ \_\_\_\_\_

\_\_\_\_\_  
Signature Print Name

**V. BID and CONTRACT FORM (Village)**

**\*\*\*THIS BID WHEN ACCEPTED AND SIGNED BY AN AUTHORIZED SIGNATORY OF THE VILLAGE OF DOWNERS GROVE SHALL BECOME A CONTRACT BINDING UPON BOTH PARTIES.**

**Entire Form Must Be Completed If a Submitted Bid Is To Be Considered For Award**

**BIDDER:**

Central Blacktop Co., Inc.

Company Name

3-18-2013

Date

6160 S. East Ave., P.O. Box 2080

Street Address of Company

Estimating@centralblacktop.com

E-mail Address

LaGrange, IL 60525

City, State, Zip

Diane Forbus

Contact Name (Print)

708-482-9660

Business Phone

708-602-9660

24-Hour Telephone

708-482-9676

Business Fax

Signature of Officer, Partner or Sole Proprietor

ATTEST: if a Corporation

James H. Loukota

Print Name & Title

Signature of Corporation Secretary

We hereby agree to furnish the Village of Downers Grove all necessary materials, equipment, labor, etc. to complete the project by August 2, 2013 in accordance with the provisions, instructions and specifications for the unit prices shown on the Schedule of Prices.

**VILLAGE OF DOWNERS GROVE:**

**ATTEST:**

Authorized Signature

Village Clerk

Title

Date

Date

In compliance with the specifications, the above-signed offers and agrees, if this Bid is accepted within 90 calendar days from the date of opening, to furnish any or all of the services upon which prices are quoted, at the price set opposite each item, delivered at the designated point within the time specified above.

**V. BID and CONTRACT FORM (Contractor)**

**\*\*\*THIS BID WHEN ACCEPTED AND SIGNED BY AN AUTHORIZED SIGNATORY OF THE VILLAGE OF DOWNERS GROVE SHALL BECOME A CONTRACT BINDING UPON BOTH PARTIES.**

**Entire Form Must Be Completed If a Submitted Bid Is To Be Considered For Award**

**BIDDER:**

Central Blacktop Co., Inc.  
\_\_\_\_\_  
Company Name

3-18-2013  
\_\_\_\_\_  
Date

6160 S. East Ave., P.O. Box 2080  
\_\_\_\_\_  
Street Address of Company

Estimating@centralblacktop.com  
\_\_\_\_\_  
E-mail Address

LaGrange, IL 60525  
\_\_\_\_\_  
City, State, Zip

Diane Forbus  
\_\_\_\_\_  
Contact Name (Print)

708-482-9660  
\_\_\_\_\_  
Business Phone

708-602-9660  
\_\_\_\_\_  
24-Hour Telephone

708-482-9676  
\_\_\_\_\_  
Business Fax

  
\_\_\_\_\_  
Signature of Officer, Partner or Sole Proprietor

ATTEST: if a Corporation

James H. Loukota  
\_\_\_\_\_  
Print Name & Title

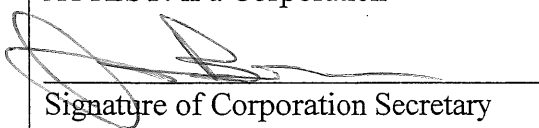
  
\_\_\_\_\_  
Signature of Corporation Secretary

We hereby agree to furnish the Village of Downers Grove all necessary materials, equipment, labor, etc. to complete the project by August 2, 2013 in accordance with the provisions, instructions and specifications for the unit prices shown on the Schedule of Prices.

**VILLAGE OF DOWNERS GROVE:**

**ATTEST:**

\_\_\_\_\_  
Authorized Signature

\_\_\_\_\_  
Village Clerk

\_\_\_\_\_  
Title

\_\_\_\_\_  
Date

\_\_\_\_\_  
Date

In compliance with the specifications, the above-signed offers and agrees, if this Bid is accepted within 90 calendar days from the date of opening, to furnish any or all of the services upon which prices are quoted, at the price set opposite each item, delivered at the designated point within the time specified above.

# 2013-2017 Capital Project Sheet

Project # **ST-004**

## Project Description **Roadway Maintenance Program**

### Project summary, justification and alignment to Strategic Plan

Capital and Motor Fuel Tax funds for on-going annual maintenance of the Village's 160 miles of streets. Projects to utilize various processes such as crack seals, pavement seals, and resurfacing with new asphalt. The funding listed as 'Other/Miscellaneous' is for asphalt purchased and rental of equipment, such as a grinder to be used by Public Works Streets Division for various patching operations during the year.

Cost Summary	New Maintenance Replacement	FY 2013	FY 2014	FY 2015	FY 2016	FY 2017	Future Years	TOTAL
		Professional Services		75,000	75,000	80,000	85,000	90,000
Land Acquisition								-
Infrastructure	X	4,620,000	4,505,000	4,585,000	5,170,000	5,800,000		24,680,000
Building								-
Machinery/Equipment								-
Other/Miscellaneous	X	116,500	115,000	146,500	145,000	176,500		699,500
<b>TOTAL COST</b>		<b>4,811,500</b>	<b>4,695,000</b>	<b>4,811,500</b>	<b>5,400,000</b>	<b>6,066,500</b>	-	<b>25,784,500</b>
<b>Funding Source(s)</b>								
220-Capital Improvements Fund	▼	3,311,500	3,545,000	3,661,500	4,250,000	4,916,500		19,684,500
102-MFT	▼	1,500,000	1,150,000	1,150,000	1,150,000	1,150,000		6,100,000
	▼							-
	▼							-
<b>TOTAL FUNDING SOURCES</b>		<b>4,811,500</b>	<b>4,695,000</b>	<b>4,811,500</b>	<b>5,400,000</b>	<b>6,066,500</b>	-	<b>25,784,500</b>

Project status and completed work  
Annual Program.

Grants (funded or applied for) related to the project.  
Motor Fuel Tax (MFT) funding also utilized.

Impact-annual operating expenses	FY 2013	FY 2014	FY 2015	FY 2016	FY 2017	Future Yrs	TOTAL
Projected Operating Expense Impact:							-

The maintenance scheduled will increase the life of the pavement. Deferral of work will significantly increase future maintenance costs.

### Map/Pictures of Project



Priority Score

A

Project Manager:

Scott Barr

Program:

342

Department:

Public Works

# 2013-2017 Capital Project Sheet

Project # **ST-043**

## Project Description **Roadway Reconstruction, Chase Rd., South of Maple**

Project summary, justification and alignment to Strategic Plan

This project includes the reconstruction of Chase Rd, from Maple Avenue to the Village Limits.

Cost Summary	New	Maintenance	Replacement	FY 2013	FY 2014	FY 2015	FY 2016	FY 2017	Future Years	TOTAL
				Professional Services				15,000		
Land Acquisition										-
Infrastructure		X		140,000						140,000
Building										-
Machinery/Equipment										-
Other/Miscellaneous										-
<b>TOTAL COST</b>				155,000	-	-	-	-	-	155,000
<b>Funding Source(s)</b>										
220-Capital Improvements Fund	▼			155,000						155,000
	▼									-
	▼									-
	▼									-
<b>TOTAL FUNDING SOURCES</b>				155,000	-	-	-	-	-	155,000

Project status and completed work

Work has not started.

Grants (funded or applied for) related to the project.

Impact-annual operating expenses	FY 2013	FY 2014	FY 2015	FY 2016	FY 2017	Future Yrs	TOTAL
Projected Operating Expense Impact:							-

The reconstruction of these roads will initially reduce current maintenance costs by eliminating the need for emergency patching, extra sweeping and removal of aggregate after snow plow operations.

### Map/Pictures of Project

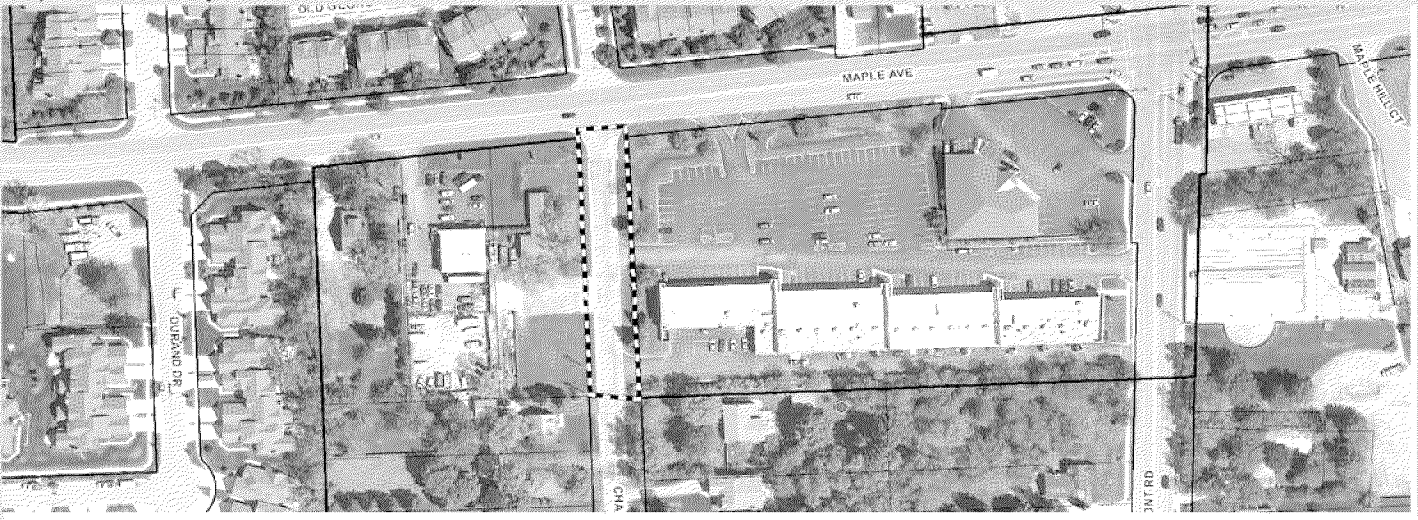

Priority Score

Project Manager:

Andy Sikich

Program:

Department:

Public Works

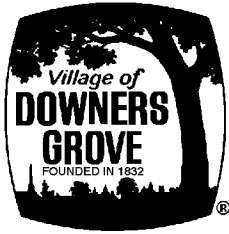

# Village of Downers Grove Contractor Evaluation

---

Contractor: Central Blacktop Company, Inc.

Project: 2012 Resurfacing (A)

Primary Contact: Charles Johns Phone: (630) 215-6711

Time Period: May 2012 – October 2012

On Schedule (allowing for uncontrollable circumstances)     yes     no

Provide details if early or late completion: Time extension to be granted due to separate underground project delaying street contractor's work.

Change Orders (attach information if needed): CO will be processed for time extension noted above and for final quantity balancing.

Difficulties / Positives: Good ongoing communication and cooperation with field and office personnel. Generally conscientious regarding specs / workmanship.

---

Interaction with public:

excellent     good     average     poor

(Attach information on any complaints or compliments)

General Level of Satisfaction with work:

Well Satisfied     Satisfied     Not Satisfied

Should the Village contract with this vendor in the future?     Yes     No

Reviewers: Scott Barr

Date: 1/11/13