

**VILLAGE OF DOWNERS GROVE  
REPORT FOR THE VILLAGE COUNCIL MEETING  
SEPTEMBER 20, 2011 AGENDA**

SUBJECT:	TYPE:	SUBMITTED BY:
Ogden Avenue Site Improvement Strategy (OASIS) Grants	✓ Resolution Ordinance Motion Discussion Only	Tom Dabareiner, AICP Community Development Director

**SYNOPSIS**

Resolutions have been prepared authorizing OASIS Grant Agreements for the following properties:

- Prestige Liquors; 739 Ogden Ave
- Mr. Submarine; 1322 Ogden Ave

**STRATEGIC PLAN ALIGNMENT**

The Strategic Goals for 2011-2018 included *Strong, Diverse Local Economy*.

**FISCAL IMPACT**

The FY11 budget includes \$750,000 from the Ogden Avenue TIF Fund for funding a matching grant program. To date, \$260,691 has been awarded. If these grants are approved, the total awarded in FY11 will be \$338,547.

**RECOMMENDATION**

Approval of the grants on the October 4, 2011 Consent Agenda

**BACKGROUND**

In September 2010, the Village Council adopted the OASIS matching grant program to enhance the Ogden Avenue corridor. The program, which was developed through a collaborative effort of the Ogden Avenue business community, the Economic Development Corporation, the Chamber of Commerce and Village staff, uses a portion of the increment generated by the Ogden Avenue TIF to provide grants for improvements to businesses within the TIF district.

The goals of the OASIS program are to:

- Provide more attractive sites
- Improve traffic circulation for vehicles and pedestrians (on private property as well as the street)
- Improve existing building appearance
- Improve signage and reduce visual clutter

This program provides business and property owners with a dollar-for-dollar matching grant for four types of eligible improvement projects: site, landscaping, façade and sign improvements, which are outlined in the OASIS policy adopted by the Village Council. Projects that incorporate multiple categories of eligible improvements may be awarded an additional 25% on top of the 50% match. The two projects being considered by the Village Council involve comprehensive site improvements. Both projects are being recommended for the 25% bonus that was authorized by the OASIS policy.

The Team recommended the following matching grant amounts:

- Prestige Liquors; 739 Ogden Ave - \$29,234.38 – 25% *bonus applied* (façade, landscaping, sign and site improvements)
- Mr. Submarine; 1322 Ogden Ave - \$48,621.88 – 25% *bonus applied*. (façade, landscaping, site and sign improvements)

A brief summary of each project is provided below:

- Prestige Liquors; 739 Ogden Ave – The applicant is proposing to update the façade of the existing building, add landscaping on the north (Ogden Avenue) of the property, close the western curb cut, remove the existing free-standing sign and install new, code compliant signs. **(Site I)**
- Mr. Submarine; 1322 Ogden Ave - The applicant is proposing to locate a new business in the vacate commercial building (formerly occupied by Kentucky Fried Chicken) and improve the façade of the existing building, add landscaping on the south (Ogden Avenue) and west (Venard Road) sides of the property and install new, code compliant signs. **(Site J)**

The OASIS Team reviewed applications in December 2010, February 2011, May 2011 and August 2011 to review applications. Twenty-seven applications were reviewed by the Team. In addition to the applications noted above, there are five applications requesting less than \$15,000 that can be approved by the Village Manager. Those applications have been forwarded to the Village Manager. With the approval of those five additional applications, the total awarded in FY11 will be \$376,422.

The OASIS Team unanimously recommended approval of the grant requests. Staff concurs with the Team's recommendation.

#### **ATTACHMENTS**

Resolution

Agreements

OASIS Grant Program Policy

Aerial Maps

OASIS recommendation letters

**RESOLUTION NO. \_\_\_\_\_**

**A RESOLUTION AUTHORIZING EXECUTION OF A GRANT  
AGREEMENT BETWEEN THE VILLAGE OF DOWNERS GROVE  
AND GDT PROPERTIES**

BE IT RESOLVED by the Village Council of the Village of Downers Grove, DuPage County, Illinois, as follows:

1. That the form and substance of a certain Grant Agreement (the “Agreement”), between the Village of Downers Grove (the “Village”) and GDT Properties (the “Applicant”), for OASIS Program grant funding, in the amount of \$48,621.88, to make improvements to the property/business located at 1322 Ogden Avenue, which is along the Ogden Avenue commercial corridor, as set forth in the form of the Agreement submitted to this meeting with the recommendation of the Village Manager, is hereby approved.

2. That the Village Manager and Village Clerk are hereby respectively authorized and directed for and on behalf of the Village to execute, attest, seal and deliver the Agreement, substantially in the form approved in the foregoing paragraph of this Resolution, together with such changes as the Manager shall deem necessary.

3. That the proper officials, agents and employees of the Village are hereby authorized and directed to take such further action as they may deem necessary or appropriate to perform all obligations and commitments of the Village in accordance with the provisions of the Agreement.

4. That all resolutions or parts of resolutions in conflict with the provisions of this Resolution are hereby repealed.

5. That this Resolution shall be in full force and effect from and after its passage as provided by law.

\_\_\_\_\_  
Mayor

Passed:

Attest: \_\_\_\_\_

Village Clerk

## OASIS GRANT AGREEMENT

THIS AGREEMENT is made this 14 day of SEPT, 2011 by and between the Village of Downers Grove, Illinois, an Illinois municipal corporation with offices at 801 Burlington Avenue, Downers Grove, Illinois 60515, ("the Village") and GDT Properties at 6339 West 26<sup>th</sup> Street, Berwyn, Illinois 60402 ("Applicant").

WITNESSETH:

WHEREAS, the Village has established the Ogden Avenue Site Improvement Strategy Program ("OASIS Program") for application to receive a grant from the Village to make improvements to properties/businesses along the Ogden Avenue commercial corridor; and,

WHEREAS, said Program is funded from TIF funds for the purpose of controlling and preventing blight and deterioration within the Ogden Avenue Tax Increment Finance District ("TIF District"), and to encourage the further redevelopment of properties in the TIF District in accordance with the general guidelines set forth in the Program as adopted in Ordinance 5150 on September 14, 2010; and,

WHEREAS, Applicant owns a property/business at 1322 Ogden Avenue, Downers Grove, Illinois 09-06-402-009 which is located within the TIF District; and

WHEREAS, pursuant to the Program the Village has agreed to financially participate, subject to its sole discretion, the Program Guidelines, and the terms and conditions set forth in this Agreement; and,

WHEREAS, the Applicant desires to participate in the Program, subject to the Program Guidelines and the terms and conditions set forth in this Agreement;

NOW THEREFORE, in consideration of the mutual covenants and agreement herein set forth, and other good and valuable consideration, the Parties do hereby agree as follows:

**A. General Provisions:**

1. The above recitals are incorporated into and made part of this Agreement as though fully set forth herein.
2. This Agreement may not be transferred or assigned.
3. This Agreement may be terminated by either party by giving ten (10) days written notice to the other party. If the Applicant terminates this Agreement, the Village shall not be required to make any reimbursement payments to the Applicant.
4. In the event the Applicant fails to complete the project and submit the required proof of payment documents in the required timeframe, the Village may terminate this Agreement and award the funds to other eligible projects.
5. The parties shall have any and all remedies available at law in the event of a breach of this Agreement.
6. Applicant acknowledges that the Freedom of Information Act may apply to public records in possession of Applicant or a contractor. Applicant and its contractors shall cooperate with the Village in its efforts to comply with the Freedom of Information Act. 5 ICLS 140/1 et. seq.
7. This Agreement will be governed by and construed in accordance with the laws of the State of Illinois. Venue is proper only in the County of DuPage.

8. This Agreement will not be subject to amendment unless made in writing and signed by all parties.
9. Any notice will be in writing and will be deemed to be effectively served when deposited in the mail with sufficient first class postage affixed, and addressed to the party at the party's place of business. Notices shall be addressed to designated representatives of both parties as follows:

Village Manager  
Village of Downers Grove  
801 Burlington Ave.  
Downers Grove, IL 60515

To the Applicant as stated below.

**B. Applicant's Obligations:**

1. Applicant shall complete the project in substantial compliance with the attached plans, incorporated as part of this Agreement as Exhibit A. Any changes to the plans shall require written approval from the Community Development Director, or his designee.
2. Applicant shall grant an easement to the Village for, or install, a public sidewalk along that portion of the subject property adjacent to Ogden Avenue where no public sidewalk currently exists.
3. Applicant, at its own expense, shall obtain all necessary permits prior to commencement of any work to complete the improvements.
4. Applicant shall submit the following required proof of payment documents:
  - a. Itemized paid-in-full invoices.
  - b. Canceled checks for the payment for the completed improvements.
  - c. Final lien waivers, if applicable.
  - d. Certified payroll records of contractors.
5. Applicant understands that it will not receive payment if there are any outstanding code violations on the property or if Applicant owes any money to the Village.
6. Applicant shall complete the project and submit the required proof of payment documents within one (1) year of the effective date of this Agreement. If the project is not completed or if the required proof of payment documents are not submitted within one (1) year, the Village shall have the right to declare this Agreement null and void and shall not be required to make any reimbursement payments to the Applicant.
7. Applicant shall complete the project in such a manner as to comply with all conditions of this Agreement, and in accordance with the Program Guidelines and all pertinent regulations, ordinances, or codes of the Village or other authority having jurisdiction over the property.
8. Applicant is hereby notified by the Village that work contemplated by this Agreement may be subject to the Prevailing Wage Act ("Act"), 820 ILCS 130/1 et seq. Applicant agrees to comply with all applicable provisions of the Act as administered by the Illinois Department of Labor ("IDOL"). Applicant further agrees to contact IDOL for a determination of applicability of the Act to the project contemplated by this Agreement. If required by IDOL, Applicant agrees to pay the prevailing wage rates and to require that all of its subcontractors pay prevailing wage to any laborers, workers or mechanics who perform work on the projects contemplated by this Agreement. For applicable rates, go to the State of Illinois – Department of Labor website and use the most current DuPage county rate. Applicant recognizes and agrees that it is solely responsible for compliance with the Act and agrees to fully indemnify, defend and hold harmless the Village with regard to any actions or proceeding instituted regarding such compliance.

9. Applicant shall be required to submit an executed Campaign Disclosure Certificate, attached hereto as Exhibit B.

C. Village's Obligations:

1. The Village shall reimburse the Applicant for one-half (1/2) of the actual incurred costs to complete all eligible aspects of the project. The amount of said reimbursement shall not exceed \$48,621.88.
2. The Village shall remit payment to the Applicant within sixty (60) days of completion of the project and receipt of the required proof of payment documents.
3. The Village shall diligently review permit submittals, issue permits and complete required inspections deemed necessary to complete the project.

IN WITNESS HEREOF, the parties set their hand and seal the day and date hereinabove written.

APPLICANT:  
Gus Tzoumas, President  
GDT Properties Inc.  
6339 West 26<sup>th</sup> Street  
Berwyn, IL 60402

VILLAGE OF DOWNERS GROVE:  
By:

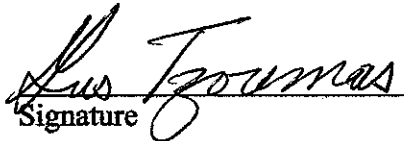
  
Signature

\_\_\_\_\_  
Village Manager

GUS TZOUMAS  
Print Name

Attest:

President  
Title

\_\_\_\_\_  
Village Clerk

**Application**

A printable version of the Ogden Avenue Site Improvement Reimbursement Grant Application is available on-line at [www.downers.us](http://www.downers.us) or [www.dgedc.com](http://www.dgedc.com). A paper copy of the application is available on the next page. Three (3) copies of the complete application, including any support documentation are due by the application deadline(s).

Applicant is:	<input type="checkbox"/> Tenant <input checked="" type="checkbox"/> Owner
Name of Business/Building:	GDT PROPERTIES, INC. DBA / MR. SUBMARINE
Address/Property ID # of Project Property:	1322 OGDEN AVE. / 09-06-402-009
Owner's Name AND TITLE:	GUS TEZOMAS, PRESIDENT, GDT PROPERTIES, INC.
Owner's Mailing Address:	6339 W. 26 <sup>th</sup> ST. BERNYN, IL. 60402
Owner's Business Phone:	708-715-4059
Owner's Fax:	708-442-5482
Owner's E-Mail:	GUSTEZOMAS@HOTMAIL.COM
PLEASE ONLY COMPLETE THE REST OF THIS TABLE IF TENANT IS THE GRANT APPLICANT.	
Tenant Name AND TITLE:	
Tenant Mailing Address:	
Business Phone for Tenant:	
E-Mail for Tenant:	

**Project Information**

*Project Description: Our goal is to give new life to the property at 1322 OGDEN AVE. (OGDEN & VENARD), which has been neglected for years and is an eyesore. The complete project includes remodeling the building from head to toe, inside and out. We realize the grant funds are not awarded for most of the work that we are planning, however what ever funds we are approved for will go a long way towards helping*

*us transform the building into a community asset.*

**Existing Site Conditions:**

Please provide a photo of current site conditions to illustrate where improvements are proposed. Photo should be provided in a paper or digital (e.g. JPEG) format. Electronic photos may be e-mailed to: [jobrien@downers.us](mailto:jobrien@downers.us).

**Written Project Description:**

Please describe your proposed project improvement. Attach pages as needed.

- \* LANDSCAPING: REMOVE DEAD TREES & BUSHES, TRIM LINE, EXISTING TREES & BUSHES  
PLANT 24 NEW BUSHES, PLANT A NEW TREE
- \* FACADE: <sup>A</sup> REPLACE 9 WINDOW FRAMES WITH NEW BRONZE METAL. <sup>B</sup> REMOVE  
DAMAGED STUCCO & BROKEN, WATER DAMAGED BRICKS. INSTALL NEW BRICKS & TUCKPOINT  
<sup>C</sup> REPLACE 9 WINDOW AWNINGS ON FRONT & SIDE OF BUILDING. <sup>D</sup> REPLACE 2  
EXTERIOR METAL & GLASS DOORS. <sup>E</sup> REPLACE DAMAGED STUCCO AREAS OF BUILDING WITH  
NEW ALUMINUM FASCIA.
- \* SIGNAGE: INSTALL NEW MONUMENT SIGN 4 1/2' H x 8' (36 SQ. FT.), REPAIR  
EXISTING FRONT WALL SIGN 6' x 9' (54 SQ. FT.), INSTALL "MR. SUBMARINE"  
INDIVIDUAL LETTERED SIGN 12" x 18" (17 SQ. FT.)

**Required Documentation For Submittal:**

3 copies of the complete application, including any support documentation are due by **August 15, 2011**. Additional copies may be requested by OASIS team after the application deadline.

1. If you are proposing an alteration to a building the following documents must be submitted (collated and stapled into packets) with the applicants name and address on the front page. Please submit legible documents, not to exceed 11" x 17" in size.

- Façade elevations (as determined necessary at pre-application meeting\*), including height, length and width measurements
- Color scheme of the proposed addition or alteration
- Building material samples (roof, siding, chimneys, etc.) if applicable
- Site plan with building outline and proposed changes
- • Cut sheets for proposed doors and windows, if applicable

If you have questions about this, please contact the Community Development Department. Specific questions about submittal requirements will be answered during the pre-application meeting.

2. If you are proposing landscape/or other site improvements the following documents must be submitted (collated and stapled into packets) with the applicants name and address on the front page. Please submit legible documents, not to exceed 11" x 17" in size.

- Site plan with building outline and proposed changes to site

- Landscape plan, if applicable (e.g. access, driveway consolidation, etc)

3. If you are proposing a new sign/awning/canopy the following documents must be submitted (collated and stapled into packets) with the applicants name and address on the front page:

- Color drawing of the sign/awning including measurements of free-standing sign and site plan showing sign location on a site
- Façade elevation showing sign/awning placement, if plan applicable

Schedule Information:

Anticipated Project Start Date: 8/25/2011

Anticipate Project Completion Date: 10/31/2011

NOTE: Completion Date must be prior within one year of the year following application.

Architect / Designer for the Project (If Applicable):

Name: BARANYK ASSOCIATES, LTD. / OREST BARANYK

Address: 710 HIGGINS RD. PARK RIDGE, IL. 60068

Phone: 847-292-5157 Fax: 847-825-8617

Contractor for the Project (If Known):

Name: BEDNARSKI CONSTRUCTION LLC

Address: \_\_\_\_\_

Phone: 708-846-7959 Fax: \_\_\_\_\_

Itemized Activity Estimated

	Total Site Improvement Costs	Grant Eligible Project Costs*	TO BE COMPLETED BY CITY	
			Grant Contribution	Bonus Award
ESTIMATE 1 Contractor Name: <u>BEDNARSKI CONST</u>	<u>54,085</u>			
ESTIMATE 2 Contractor Name: <u>DIALED CONT. LLC</u>	<u>61,950</u>			

Two detailed contractor estimates are required. Please provide additional sheets with supporting detail as necessary.

This application for a Site Improvement Reimbursement Grant is hereby believed to be complete and accurate.

*Gus Teunema*  
Owner Signature:

Tenant Signature:

Print Owners Name:  
*GUS TEUNEMA*  
*QDT PROPERTY*

Print Tenant Name:

NOTE: Tenant Signature only necessary if  
Tenant is applying for a Grant

STATE OF ILLINOIS  
COUNTY OF DUPAGE  
VILLAGE OF DOWNERS GROVE

The foregoing petition was acknowledged before me by on this 15 day of  
AUGUST, 2011.

Notary Public:

*Caryn Teune*

Notary Public

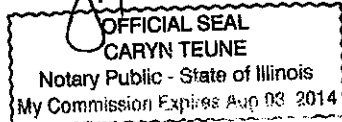

3 Copies of the completed application should be submitted to the Village's  
Community Development Department.

Applications may be dropped off at the Village Hall from 8:00 am and 5:00 pm  
Monday – Friday, or mailed to:

Village of Downers Grove  
ATTN: Community Development Department  
801 Burlington Avenue  
Downers Grove, IL 60515

**Disclosure of Beneficiaries/Trust Disclosure:**

The information requested below must be completed and attached to any grant application submitted to the Village of Downers Grove. This form is used to ensure that the applicant has a recognized, vested interest in the property. This form is required by persons applying for permits, licenses, approvals or benefits from the Village of Downers Grove  
Village of Downers Grove

**DISCLOSURE OF BENEFICIARIES**

1. Grant Applicant: GDT PROPERTIES
2. Address: 1372 OGDEN AV, DOWNERS GROVE, I L
3. Nature of Applicant (Please circle one):
  - a. Natural Person
  - b. Corporation
  - c. Land Trust/ Trustee
  - d. Trust/Trustee
  - e. Partnership
  - f. Joint Venture
4. If applicant is an entity other than described in Section 3, briefly state the nature and characteristics of applicant:
5. If in your answer to Section 3 you checked box b, c, d, e or f, identify by name and address each person or entity which is a 5% shareholder in the case of a corporation, a beneficiary in the case of a trust or land trust, a joint venture in the case of case of a joint venture, or who otherwise has a proprietary interest, interest in profits and losses or right to control such entity:
  - a. GUS TZOUMAS
  - b. DEAISE TZOUMAS
  - c. NICK TZOUMAS, DAN TZOUMAS
  - d. TINA TZOUMAS, JAMIA REVELIOTIS
6. Name, address and capacity of person making this disclosure on behalf of the applicant:

**IMPORTANT NOTE:** In the event your answer to Section 5 identifies entities other than a natural person, additional disclosures are required for each entity.

VERIFICATION I, GUS TZOUMAS, being first duly sworn under oath, depose and state that I am the person making this disclosure on behalf of the applicant, that I am duly authorized to make this disclosure, that I have read the above and foregoing Disclosure of Beneficiaries, and that the statements contained therein are true in both substance and fact.

Signature: Gus Tzoumas

Subscribed and Sworn to before me this 15<sup>th</sup> day of August, 20 11.

Caryn Teune Notary Public



---

Above space for Recorder's Use Only

**SHERIFF'S DEED**

**THE GRANTOR**, John E. Zaruba, Sheriff for DuPage County, Illinois, pursuant to and under the authority conferred by the provisions of a Judgment of Foreclosure and Sale entered by the Circuit Court of DuPage County, Illinois, on April 26, 2010, in Case 2009 CH 4386, entitled *NATIONAL CITY BANK v. TW METROPOLITAN LLC, an Illinois limited liability company, STANDARD BANK & TRUST CO., as Trustee under Trust No. 19509 dated June 26, 2006, JOHN TERZAKIS, Unknown Owners and Non-Record Claimants*, and pursuant to which the premises hereinafter described were sold at public sale pursuant to notice given in compliance with 735 ILCS 5/15-1507(c) by said grantor on September 14, 2010, does hereby grant, transfer, and convey to G.D.T. Properties, Inc., an Illinois corporation, by assignment the following described real estate situated in the County of DuPage, in the State of Illinois, to have and to hold forever:

The Southerly 60.0 feet of Lot 21 an all of Lots 22 and 23 in Arthur T. McInctosh and Company's Downers Grove Acres, being a subdivision of part of the East half of Section 6, Township 38 North, Range 11, East of the Third Principal Meridian, and of the Southeast quarter of Section 31, Township 39 North, Range 11, East of the Third Principal Meridian, according to the plat thereof recorded June 26, 1924 as document number 179451, (excepting therefrom that part taken for Ogden avenue), in DuPage County, Illinois.

The Real Estate is commonly known as 1322 Ogden Avenue, Downers Grove, Illinois.

Pin Number: 09-06-402-009-0000

**TO HAVE AND TO HOLD** the same, with all improvements and buildings thereon, all rights to any and all streets, alleys or publicways adjacent thereto (before and after vacation thereof), all easements benefitting such real estate or appurtenant thereto, all water, water rights, air, air rights, and development rights relating thereto or arising in connection therewith (including, without limitation, all rights created pursuant to any encumbrance to title), and all other rights, tenements, hereditaments, conservation areas, appurtenances thereto belonging or in anywise appertaining to the property described herein, and all improvements thereon, and

fixtures attached to or used in connection with said premises, unto G.D.T. Properties, Inc., an Illinois corporation, forever.

Witness the Hand and Seal of said Grantor,  
Dated this 20<sup>th</sup> day of June, 2011.

John E. Zaruba (SEAL)

John E. Zaruba  
Sheriff of DuPage County, Illinois

W.A.U.  
Deputy Sheriff of DuPage County, Illinois

STATE OF ILLINOIS        )  
  ) SS:  
COUNTY OF DUPAGE        )

I, the undersigned, a Notary Public in and for said County, in the State aforesaid, DO HEREBY CERTIFY that Ment Kouba, personally known to me to be the same person whose name as Deputy Sheriff of DuPage County, Illinois, is subscribed to the foregoing instrument, appeared before me this day in person, and acknowledged she signed, sealed and delivered the said instrument as her free and voluntary act as such Deputy Sheriff, for the uses and purposes therein set forth.

Given under my hand and official seal,  
this 20<sup>th</sup> day of June, 2011.   IMPRESS SEAL HERE

Agnes Biondi  
NOTARY PUBLIC

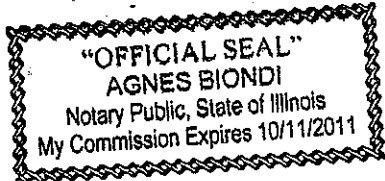

Commission expires \_\_\_\_\_, 20\_\_.

ADDRESS OF GRANTEE & TAX BILLS TO:

G.D.T. Properties, Inc.  
c/o Gus Tzoumas  
6339 W. 26th St.  
Berwyn, IL 60402  
(708) 795-0800

Prepared by and Mail to:

David Z. Smith  
Stephen R. Miller  
Reed Smith LLP

10 South Wacker Drive -40th Floor  
Chicago, IL 60606-7507  
(312) 207-3860  
(312) 307-6400 (fax)  
Attorney No. 75160

US\_ACTIVE-106337610.1

1230  
90  
1000  
110621

# 3

IN THE CIRCUIT COURT FOR THE EIGHTEENTH JUDICIAL CIRCUIT  
DUPAGE COUNTY, ILLINOIS

*Chas. Robinson*  
CLERK OF THE  
18th JUDICIAL CIRCUIT  
DU PAGE COUNTY, ILLINOIS

11 JUN 20 PM 2:52

FILED

NATIONAL CITY BANK,

Plaintiff,

vs.

TW METROPOLITAN LLC, an Illinois limited  
liability company, STANDARD BANK & TRUST  
CO., as Trustee under Trust No. 19509 dated June  
26, 2006, JOHN TERZAKIS, UNKNOWN  
OWNERS, and NON-RECORD CLAIMANTS,

Defendants.

Civil Action No. 09 CH 4386

Judge Bonnie M. Wheaton

**ORDER APPROVING REPORT OF SALE AND DISTRIBUTION,  
ENTERING DEFICIENCY JUDGMENT, PLACING PLAINTIFF'S ASSIGNEE AS  
MORTGAGEE IN POSSESSION, AND ENTERING ORDER OF POSSESSION**

This cause comes to be heard on Plaintiff's amended motion for the entry of an Order Approving Report of Sale and Distribution, confirming the sale of the premises, which are the subject of the matter captioned above and described as (the "Property"):

The Southerly 60.0 feet of Lot 21 an all of Lots 22 and 23 in Arthur T. McInctosh and Company's Downers Grove Acres, being a subdivision of part of the East half of Section 6, Township 38 North, Range 11, East of the Third Principal Meridian, and of the Southeast quarter of Section 31, Township 39 North, Range 11, East of the Third Principal Meridian, according to the plat thereof recorded June 26, 1924 as document number 179451, (excepting therefrom that part taken for Ogden avenue), in DuPage County, Illinois.

The Real Estate is commonly known as 1322 Ogden Avenue, Downers Grove, Illinois.

Pin Number: 09-06-402-009-0000

Due notice of said motion having been given, the Court having examined said Report and being fully advised in the premises, **FINDS:**

This Court entered a Judgment of Foreclosure and Sale on April 26, 2010 (the "Judgment"). Pursuant to that Judgment, a Notice of Sale was issued, providing public notice of a sale pursuant to the Judgment and setting that sale for September 14, 2010. The Notice of Sale was duly served and published;

The sale proceeded on September 14, 2010 and Plaintiff presented the high bid. The Court has been presented with a Report of Sale and Distribution regarding the sale;

All notices required by 735 ILCS 5/15-1507(c) have been properly given;

The sale was fairly and properly made;

The Sales Officer has in every respect proceeded in accordance with the terms of this Court's Judgment;

Plaintiff, as the successful bidder, is entitled to a deed of conveyance and possession of the Property;

Since becoming the successful bidder, Plaintiff has assigned its right, title, and interest as successful bidder to G.D.T. Properties, Inc., an Illinois Corporation ("G.D.T."), and under the terms of that assignment, a deed sufficient to convey title is to be issued to G.D.T.;

That justice was done; and

That the name, address and telephone number of the party to whom the Sheriff's Deed will be issued is:

G.D.T. Properties, Inc.  
c/o Gus Tzoumas  
6339 W. 26th St.  
Berwyn, IL 60402  
(708) 795-0800

**IT IS THEREFORE ORDERED:**

1. The sale of the Property involved herein and the Report of Sale and Distribution filed by the Sales Officer are hereby approved, ratified and confirmed;
2. The assignment from Plaintiff to G.D.T. of Plaintiff's right, title and interest as successful bidder is hereby approved;
3. The proceeds of the sale shall be distributed in accordance with the Report of Sale and Distribution;
4. The Mortgagee's fees and costs arising between the entry of the Judgment of Foreclosure and Sale and the date of sale are approved, ratified and confirmed;
5. Upon request by G.D.T., as assignee of the successful bidder, and provided that all required payments have been made pursuant to 735 ILCS 5/15-1509, the Selling Officer shall

execute and deliver to G.D.T., as the assignee of the right, title, and interest of the successful bidder, a deed sufficient to convey title;

6. G.D.T., as assignee of the successful bidder, is entitled to immediate possession of the Property as mortgagee in possession pursuant to 735 ILCS 5/15-1701(c), and G.D.T. shall have full possession of the Property as of 30 days after entry of this Order July 20, 2011), without further order of court, as provided in 735 ILCS 5/15-1701;

7. The Sheriff of DuPage County is directed to, without further order of court, evict and dispossess, as of 30 days after entry of this Order July 20, 2011), any and all Defendants who are in possession of the property from the subject property commonly known as:

1322 Ogden Avenue, Downers Grove, Illinois

8. There is an IN PERSONAM deficiency judgment entered in favor of National City Bank and against TW Metropolitan LLC and John Terzakis in the amount of \$12,761,853.33, with interest thereon as provided by statute;

9. 735 ILCS 5/9-117 is not applicable to this order. This is a final and appealable order with no just cause for further delay.

ENTER: Marnie M. Keeter  
Judge

DATED: 06-20-11

PHILIP R. SHELDON  
DEPUTY CLERK

Order prepared by:

David Z. Smith  
Stephen R. Miller  
Reed Smith LLP  
10 South Wacker Drive -40th Floor  
Chicago, IL 60606-7507  
(312) 207-3860  
(312) 307-6400 (fax)  
Attorney No. 75160

*Attorneys for Plaintiff*

Thorp Asphalt, Inc.  
 2725 W 87th Street  
 Evergreen Park, IL 60805

# Proposal

Date	S.O. No.
8/22/2011	16

Name / Address
Mr. Submaines 1322 East Orlgen Avenue Downer Grove, IL

Ship To
Mr. Submaines

P.O. No.	Terms	Project

Description	Quantity	Unit	Rate	Amount
Remove existing asphalt from parking lot ,saw cut west side of parking lot			0.00	
regrade parking lot with 2 inches of binder install surface 1" inch of asphalt, price also includes striping parking lot (yellow lines) 9- 12 car stops.	11,500	SF	2.47	28,405.00
2" of binder and 1" of surface	11,500	SF	0.51	5,865.00
Asphalt removal				
<b>Total</b>				\$34,270.00

Signature \_\_\_\_\_

# PROPOSAL

## LEMONT PAVING COMPANY • MURPHY'S

Established 1957

11550 Archer Avenue • Lemont, Illinois 60439 • (630) 257-8701 • Fax (630) 257-3194

G. D.T Properties  
6339 W. 126th Street  
Berwyn, IL 60402

Mr. Gus. Tzoumas

Fax # 708 442 5482

Job Site: 1322 Ogden, Downers Grove, IL

DATE

JOB NO.

8/14/2011

6287

Description

Total

### B. Total Removal

1. Excavate and remove old asphalt and haul to a recycling facility.
2. Examine the stone base and remove soft areas.
3. Add necessary stone.
4. Grade and compact the stone base with a vibratory roller.
5. The hot mix asphalt will be machine layed in two lifts to a total of 3 inches thick.  
( 2 inches binder and 1 inch surface asphalt)
6. All applicable permits will be paid by owner.
7. Striping as per owner.

PRICE:

Final payment to be made Upon Completion

29,745.00

Please call if you have any questions regarding the proposal. We look forward to hearing from you. Thank you.

All material is guaranteed to be as specified. All work to be completed in a workmanlike manner according to standard practices. Any alteration or deviation from above specifications involving extra costs will be executed only upon written orders, and will become an extra charge over and above the estimate. All agreements contingent upon strikes, accidents or delays beyond our control. Owner to carry fire, tornado and other necessary insurance. Our workers are fully covered by Workman's Compensation Insurance.

Default: In the event of default in payment or otherwise by owner/agent, at the option of contractor, the entire unpaid balance shall become immediately due and payable and interest shall accrue at 18% per annum pro rata until fully paid. Contractor may accept payments after default without prejudice but is not obligated to do so, without waiver of right to pursue collection of the entire balance due. Owner/agent agrees to pay all attorneys fees, costs and expenses of Contractor in the event contractor takes legal action to collect the balance due.

Venue: This agreement shall be governed by the laws of the State of Illinois. Owner/agent consents to the jurisdiction and venue of any court located in the county of DuPage, State of Illinois in the event of any legal proceeding pertaining to the negotiation, execution, performance or enforcement of any term or condition contained in this agreement or any related document and agrees not to commence or seek to remove such legal proceeding in or to a different court and/or county.

If any provision of this contract violates the law or is unenforceable, the rest of the contract shall remain valid.

This Agreement constitutes the entire agreement and supercedes all other prior agreements and understandings, both written and oral, among the parties or any of them, with respect to the subject matter thereof.

This contract is subject to all of the provisions of the contract of Lemont Paving Company dated \_\_\_/\_\_\_/\_\_\_ which is incorporated herein by reference. If any of the terms of this contract conflict with the terms of the contract of Lemont Paving Company dated \_\_\_/\_\_\_/\_\_\_, the terms of the Lemont Paving Company dated \_\_\_/\_\_\_/\_\_\_ contract shall control.

### Acceptance of Proposal

The above prices, specifications and conditions are satisfactory and are hereby accepted. You are authorized to do the work as specified. Payment will be made as outlined above.

Signature \_\_\_\_\_

Date \_\_\_\_\_

Signature \_\_\_\_\_

Date \_\_\_\_\_

# Dialed in Contractors LLC

Dialed in Contractors LLC  
 914 West 195th Street  
 Chicago Heights, IL 60411

(708)932-9918  
 dialedincontractors@comcast.net

## Estimate

DATE	estimate #
08/13/2011	1190
	EXP. DATE

ADDRESS
Gus Tzoumas

Activity	Quantity	Rate	Amount
• tree and bush trimming remove dead trees and bushes, install 24 bushes and 2 new evergreens trees	1	6,250.00	6,250.00
• Replace nine window frames with new bronze metal. Remove damaged stucco and broken bricks that were damaged by water. Repair and replace bricks and tuckpoint. Replace 9 awnings above windows on the front and the side of the building. Replace 2 exterior metal \$ glass doors. Remove old broken stucco and replace with new aluminium metal fascia on front and side of building	1	36,750.00	36,750.00
• signage improvements-monument sign 4 1/2' H x 8" W = 36 sq ft existing front wall sign 6' x 9' = 54 sq ft east side Mr. Submarine 11 individual letters 12" x 18" = 17 sq ft	1	18,950.00	18,950.00
		<b>TOTAL</b>	<b>\$61,950.00</b>

Mr. Submarine  
 1322 W Ogden Ave  
 Downers grove IL

Accepted By:

Accepted Date:



**PROPOSAL**

1130 N. Garfield, Lombard, IL 60148  
www.oly signs.com

Phone: 630/424-6100  
Fax: 630/424-6120

Name and Address:	Mr. Submarine 1322 Ogden Ave Downers Grove, IL 60515	August 12, 2011
Phone	708-715-4059	
Job Name and Location	Same as above	

- A) Fabricate and install one internally illuminated double sided monument type ground sign.  
6'x6' aluminum sign cabinet, flat lexan face panels with vinyl graphics, fluorescent illumination,  
4'x5' aluminum base, steel support with concrete footing.  
Price..... \$8,900.00
- B) Furnish and install one 6'x9' flat lexan face panel for existing sign cabinet on storefront elevation.  
Lighting repairs extra if required.  
Price..... \$2,100.00
- C) Furnish and install one 3'x3' illuminated single face sign box. Flat lexan face panel with vinyl logo.  
Fluorescent illumination.  
Price..... \$1,450.00
- D) Furnish and install one illuminated channel letter wall sign. 30"x30" logo box, 15" channel letters  
reading "Submarine". LED illumination.  
Price..... ~~\$6,500.00~~ **18,950**
- E) Furnish and install ten decorative aluminum awnings. Approximately 24" drop, 36" projection, 72" length.  
Price..... \$1,500.00 each \$15,000.00

- Deposit half required, balance due C.O.D.
- Permit and procurement cost is extra.

Authorized Signature   
Ed Pyter

NOTE: We may withdraw this contract if not accepted within (30) days.

**ACCEPTANCE OF CONTRACT**

The above prices, specifications and conditions are satisfactory and are hereby accepted. You are authorized to do the work as specified. Payment will be made as outlined above.

Accepted: \_\_\_\_\_ Signature \_\_\_\_\_

Date \_\_\_\_\_ Print Name \_\_\_\_\_

- Specializing In:**
- WINDOWS
  - DECKS
  - DRY WALL

# BEDNARSKI CONSTRUCTION LLC

(708) 846-7959 • (773) 892-7375

Licensed • Bonded • Insured

- FRAMING
- CONCRETE
- PORCHES
- AND MORE...

**BEDNARSKI CONSTRUCTION LLC**

(NAME AND BUSINESS ADDRESS OF SELLERS - HEREINAFTER REFERRED TO AS SELLER)

, hereby

Sells and, GDT PROPERTIES, INC / 1322 OGDEN AV.

(NAME OF BUYER - HEREINAFTER REFERRED TO AS BUYER)

hereby

**Purchases from SELLER the following described GOODS AND SERVICES:**

BEDNARSKI CONSTRUCTION LLC, hereby offers for the amount shown below, and subject to the below listed conditions and those stated on the reverse side hereof, to furnish, deliver, and install (where proposal covers installation) the materials listed below in accordance with the specifications set forth below and sketches,

This agreement made this 12th day of August 2011

Names (Buyer) Gus Tzoumas

Residence 6339 W. 26th St. Phone: Bus. 708-715-4059 Res                     

of the City of BERWYN Zip 60402 country of                      State of IL

**LANDSCAPING:** Remove, clean, trim wild trees & bushes. Plant 24 new bushes  
Plant new tree. \$5,150

**FACADE IMPROVEMENTS:** Remove damaged stucco around building, replace with new metal fascia. Replace 2 bronze doors, 1 single & 1 double. Replace 9 window awnings. remove damaged stucco panels, replace with new bricks & tuckpoint. Replace 9 old & painted window frames with new frames. \$34,500

**SIGNAGE IMPROVEMENT:** Install new monument sign (4 1/2' x 8'). Replace existing wall sign (6'x9'). Install "Mr. Submarine" Lettering (12"x18") \$14,435

**SCHEDULING OF WORK TO BE PERFORMED** - It is understood that the seller will order custom-made materials for buyer(s) to be installed as described above Buyer agrees that the measurement of the job and the installation of materials shall be scheduled to begin within five (5) days after notice by Seller and all work shall be scheduled for week days unless specifically noted above.

**NOTICE TO BUYER**

1. Do not sign this agreement before you read it or if it contains any blank spaces.
2. You are entitled to an exact copy of the agreement you sign.

YOU, THE BUYER MAY CANCEL THIS TRANSACTION AT ANY TIME PRIOR TO MIDNIGHT OF THE THIRD BUSINESS DAY AFTER THE DATE OF THIS TRANSACTION. SEE REVERSE SIDE FOR AN EXPLANATION OF THIS RIGHT.

BUYER AND EACH CO-SIGNER ACKNOWLEDGE THAT COMPLETELY FILLED-IN COPY OF THIS CONTRACT SIGNED BY SELLER, HAS BEEN DELIVERED TO AND RETAINED BY BUYER AND SUCH CO-SIGNER.

This contract is subject to all of the terms set forth on the face and reverse side. By executing this instrument, Buyer(s) agrees to all terms and conditions. PLEASE READ REVERSE SIDE BEFORE SIGNING.

**The BUYER agrees:**

1. To secure all necessary building permits.
2. To pay for said work the following:

Cash Price .....	\$	<u>                    </u>
Total Amount of Contract .....	\$	<u>54,085</u>
Deposit with this Contract .....	\$	<u>                    </u>
On Measure .....	\$	<u>                    </u>
On Start .....	\$	<u>                    </u>
On Completion of Job C.O.D. Balance \$		<u>                    </u>

Executed this 12th day of AUGUST 2011

**SELLER**

BEDNARSKI CONSTRUCTION LLC

(Authorized Contractor)

BY Marcus Bednarski

TITLE OWNER

BUYER GDT PROPERTIES, INC

BUYER DBA/ MR SUBMARINE

CO-SIGNER Gus Tzoumas

\* JOB SITE / 1322 OGDEN AV, DOWNERS GROVE, IL

---

## Signs-Downers Grove Drawings & Proposal

---

From: **Chuck Alden** (calden1@sbcglobal.net)

Sent: Mon 8/15/11 10:09 AM

To: Gus Tzoumas (gustzoumas@hotmail.com)

3 attachments

11-0483-A.pdf (772.1 KB) , 11-0484.pdf (651.6 KB) , 11-0486.pdf (465.4 KB)

Gus,

Installed pricing for the attached three (3) signs is as follows:

36 sq.ft. Double-face, internally-illuminated Monument Sign per Design #11-0483-A ...\$6,900.00

54 sq.ft. Single-face, internally-illuminated Wall sign reface per Design #11-0484 .... \$1,900.00

Add new lamps & ballasts to the above wall sign ..... \$955.00

84 sq.ft. Channel Logo & Raceway-Mtd. Letters on East wall per Design #11-0486 ...\$4,680.00

Total for three (3) signs .... \$14,435.00

Total Area for all three (3) Signs .... 174 sq.ft. (Allowed 177 sq.ft.)

Chuck Alden

Sales

Chuck Alden

Sign Consultant

Grate Signs, Inc.

4044 W. McDonough Ave.

Joliet, IL 60431

Ph: 815/729-9700 x153

Fx: 815/729-3355



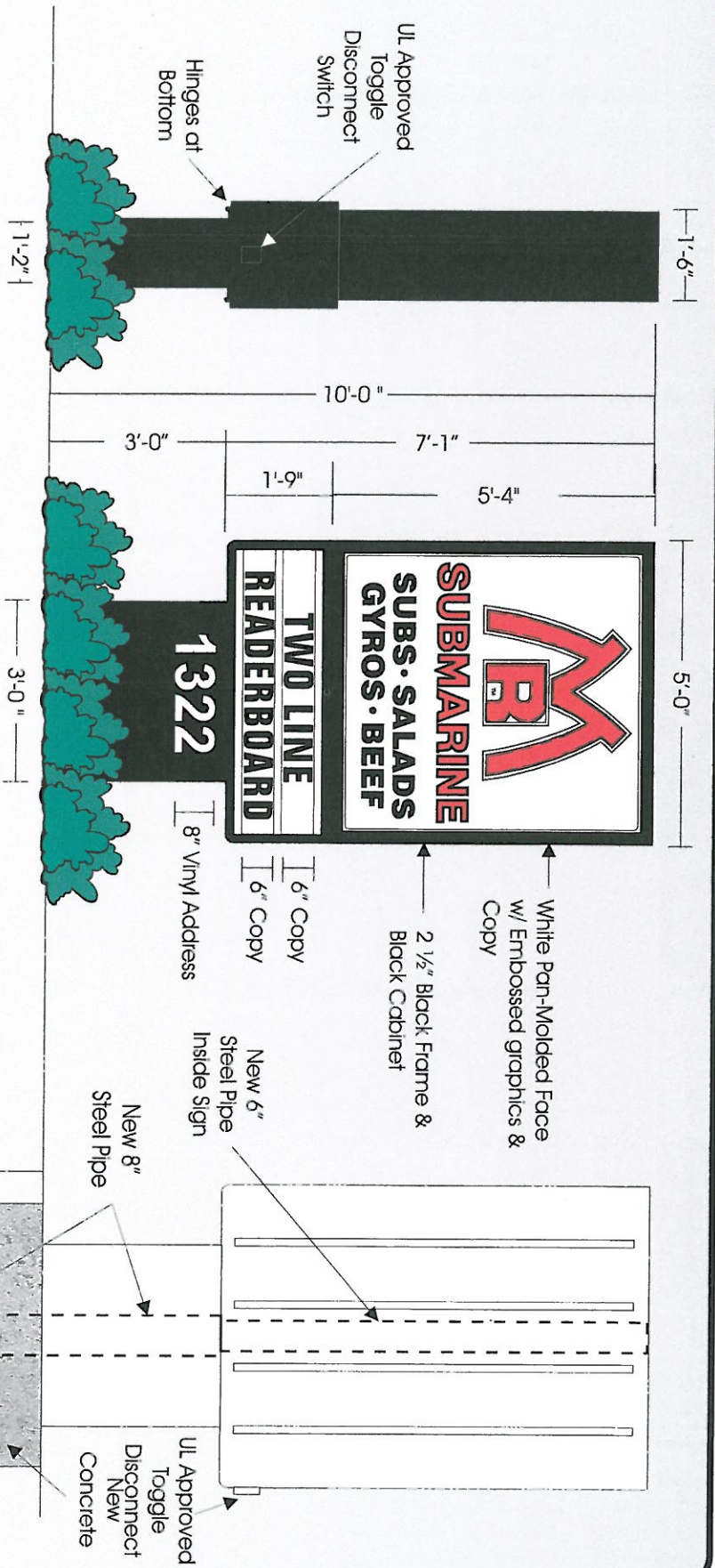

**One (1) Double Face Pan-Molded & Embossed Internally Illuminated Monument Sign**

White Pan-Molded face  
 Embossed graphic & copy  
 Cabinet, Faces & Retainers Painted Black  
 Changeable Copy Board with 2 Lines of 6" Zip Letters. Clear Lexan Security Door with 2 1/2" Frame, Hinges at Bottom & Lock at Top  
 Pylon Painted Black  
 White Vinyl Address Graphic Applied to Pylon

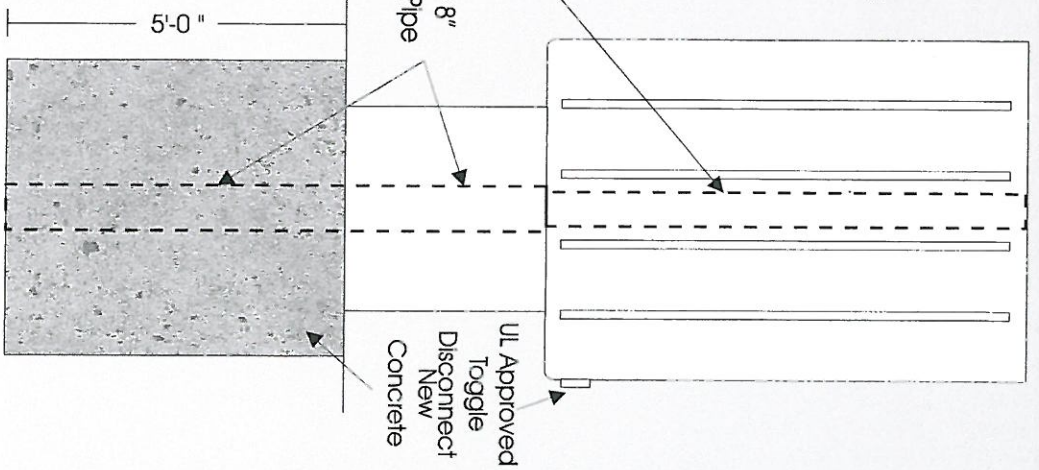
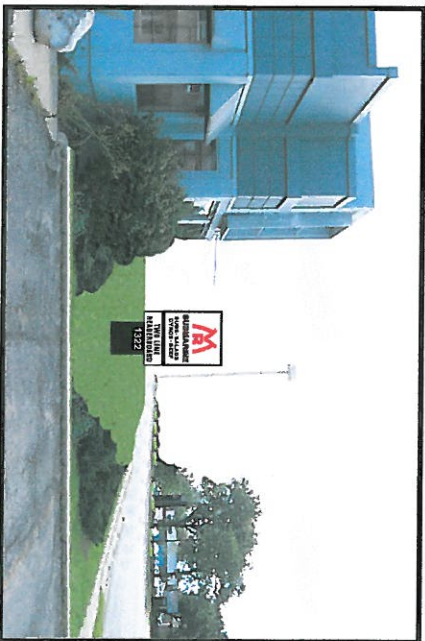

Client: Mr. Submarine - Downers Grove  
 Approved:  
 Scale: 1/2" = 1'

Drawing #: 11-0483-A  
 Drawn By: JTG  
 Rev By:

Date: 8-12-11  
 Rev Date:

All sign designs and concepts shown here are confidential and are the property of Grate Signs, Inc. They are not to be distributed, exhibited, copied, or otherwise used without our written permission. COMPUTER GENERATED COLORS ARE NOT A TRUE MATCH TO ANY PMS, VINYL, OR PAINT!

GRATE SIGNS  
 (800) 888-8888

6'-0"

9'-0"

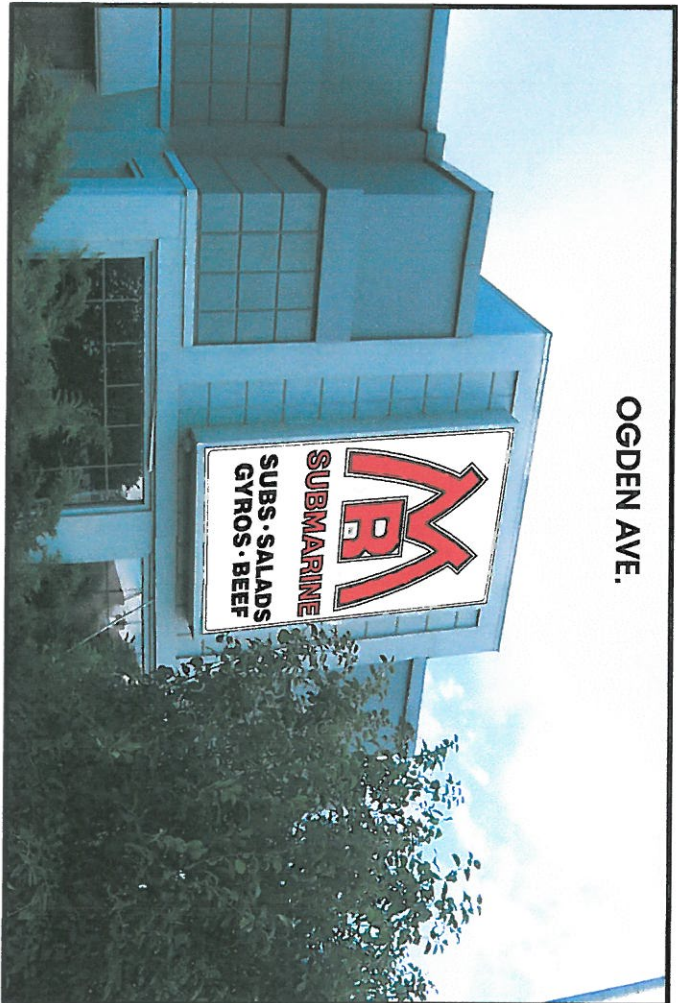

OGDEN AVE.

**Reface existing Internally-Illuminated  
Single-Face Wall Sign**

White Pan-Molded Face      Lacryl #443-R Deep Red  
w/ Embossed graphics &      w/ Black copy & outlines  
Copy

Client: Mr. Submarine	Dwng # 11-0484
Approved:	Date: 8-12-11
Sales: Alden	Rev Date:
Drawn by: JIG	Last Revised by:
Scale: 1/2" = 1'	

All sign designs and concepts shown here are confidential and are the property of Grate Signs, Inc. They are not to be distributed, exhibited, copied, or otherwise used without our written permission.

**COMPUTER GENERATED COLORS ARE NOT A TRUE MATCH TO ANY PMS, VINYL, OR PAINT.**



© Grate Signs, Inc. 2010

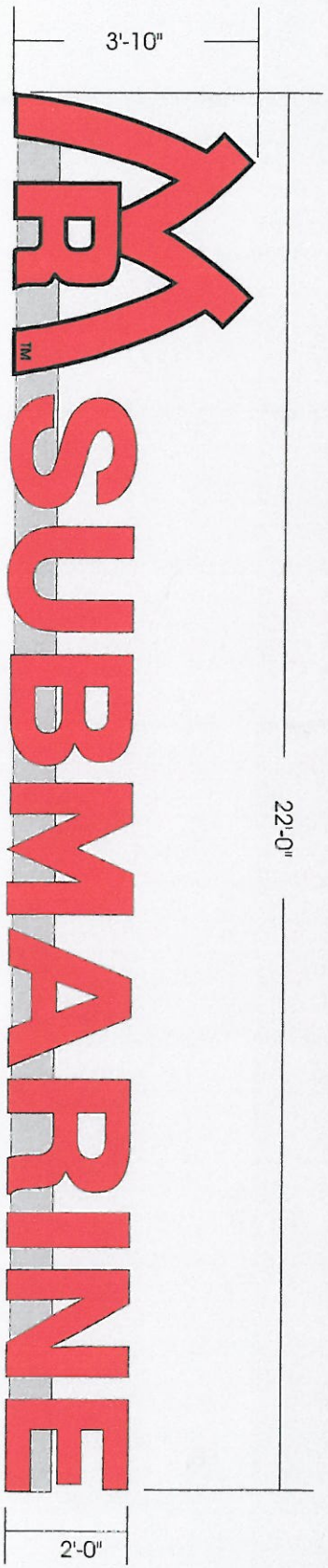

84 sq. ft.

**One (1) Set Illuminated Logo & Raceway-Mounted Channel Letters**

#278-R Red Acrylic Faces with Black Trimcap  
Returns Painted Black

Black Vinyl "TM" Symbol & Black Vinyl Outline on Logo Face

LED Illumination with Low Voltage Power Supply  
Raceway painted to match fascia

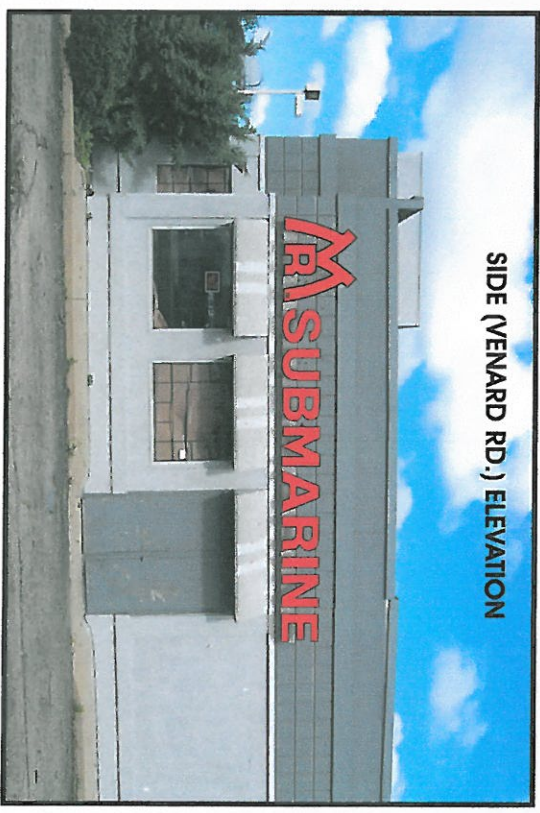

SIDE (VENARD RD.) ELEVATION

photo not to scale

Client: Mr. Submarine - Downer's Grove	Drawing #: 11-0486
Approved:	Drawn By: JTG
Scale: 3/8"=1'	Sales: Alden
	Rev By:
	Date: 8-15-11
	Rev Date:

All sign designs and concepts shown here are confidential and are the property of Grate Signs, Inc. They are not to be distributed, exhibited, copied, or otherwise used without our written permission.

**COMPUTER GENERATED COLORS ARE NOT A TRUE MATCH TO ANY PMS, VINYL, OR PAINT.**



PROPOSE NEW STORE



OLD STORE



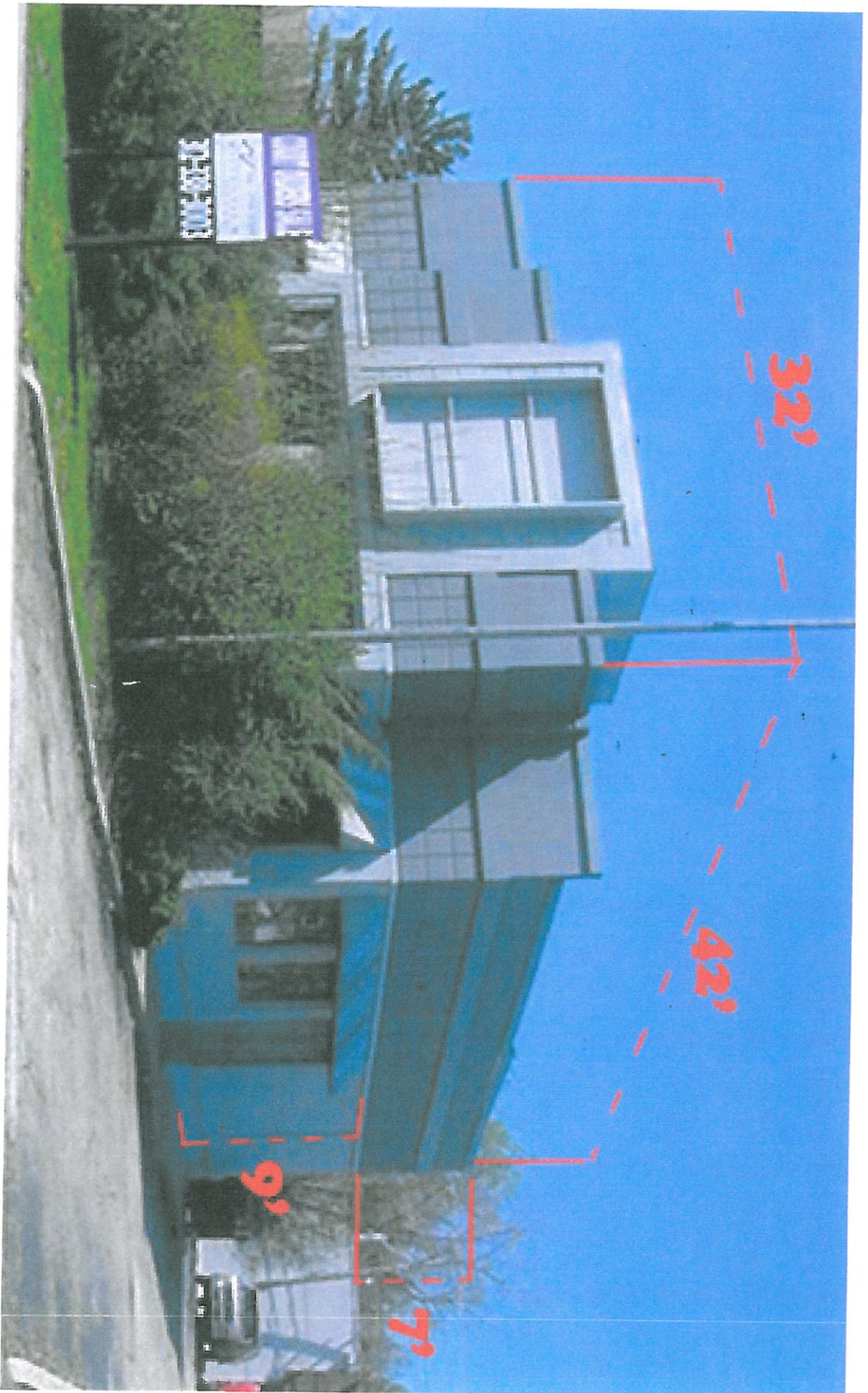

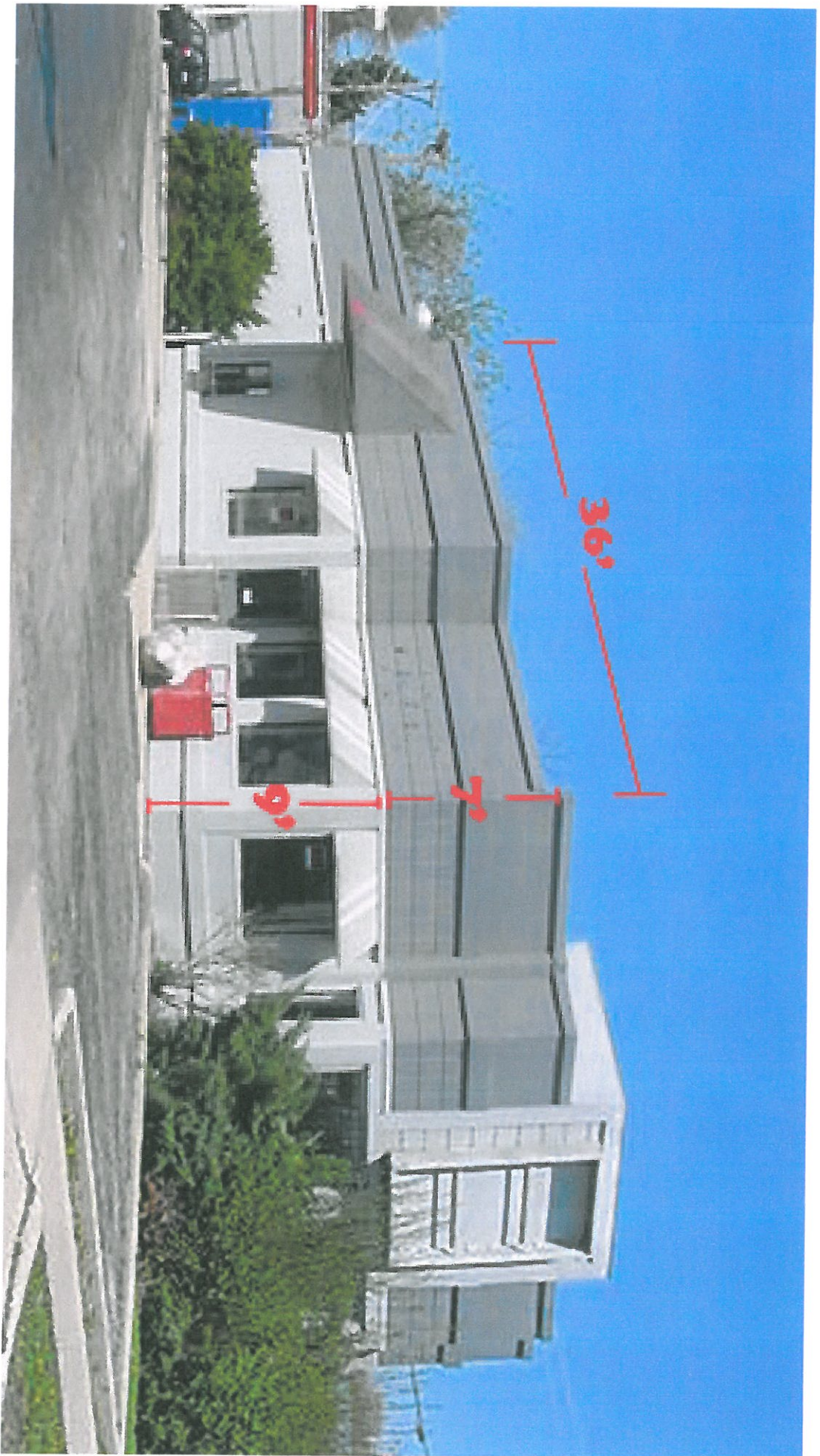

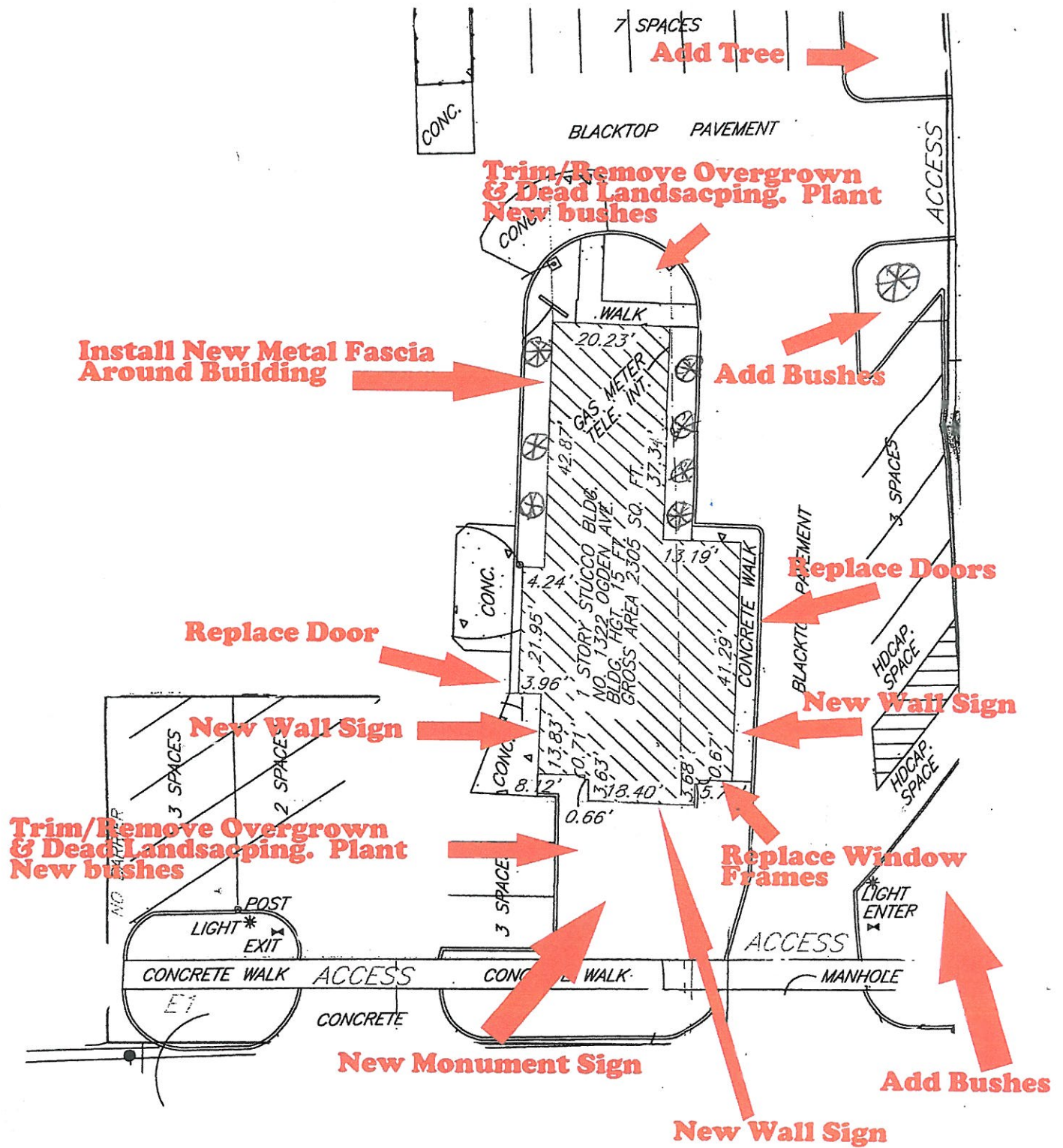

1322 - OGDEN - AVENUE

# Oldcastle BuildingEnvelope™ — a market leader in Standard Entrances



Oldcastle BuildingEnvelope™ offers standard, narrow, medium and wide stile entrances to **meet a wide range of traffic** requirements. All standard Oldcastle BuildingEnvelope™ entrances (3' 0" wide) are ADA compliant and have built-in features.

## Specifications

Oldcastle BuildingEnvelope™ entrances are durable and virtually maintenance free. We also offer a complete line of custom, specialty and all-glass entrances.

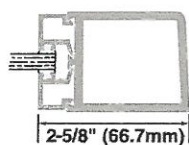

Series 212 – Narrow Stile

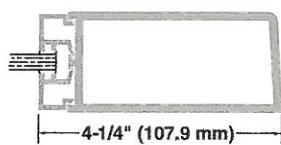

Series 375 – Medium Stile

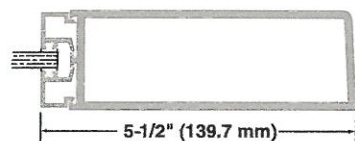

Series 500 – Wide Stile

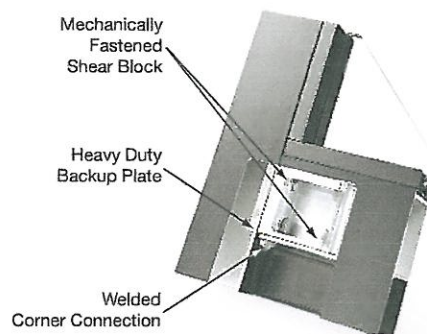

Pac Bell Park, San Francisco, CA  
Architect: HOK Sport

## Features

- Maximum security hook bolt locks
- 1" diameter push/pulls
- Adjustable astragal with dual weathering on pairs of doors
- Mechanically fastened shear blocks and welded corner construction
- Adaptable to virtually all hardware
- 4" to 10" one piece bottom rail options
- Glass stops with bulb gaskets
- 1/4", 3/8", 5/8" and 1" glazing options
- Adaptable to meet local building codes
- Limited lifetime warranty



Hardware

Oldcastle BuildingEnvelope™ employs only the finest entrance door hardware available. For more information, call (972) 551-6100 or visit [oldcastlebe.com](http://oldcastlebe.com).

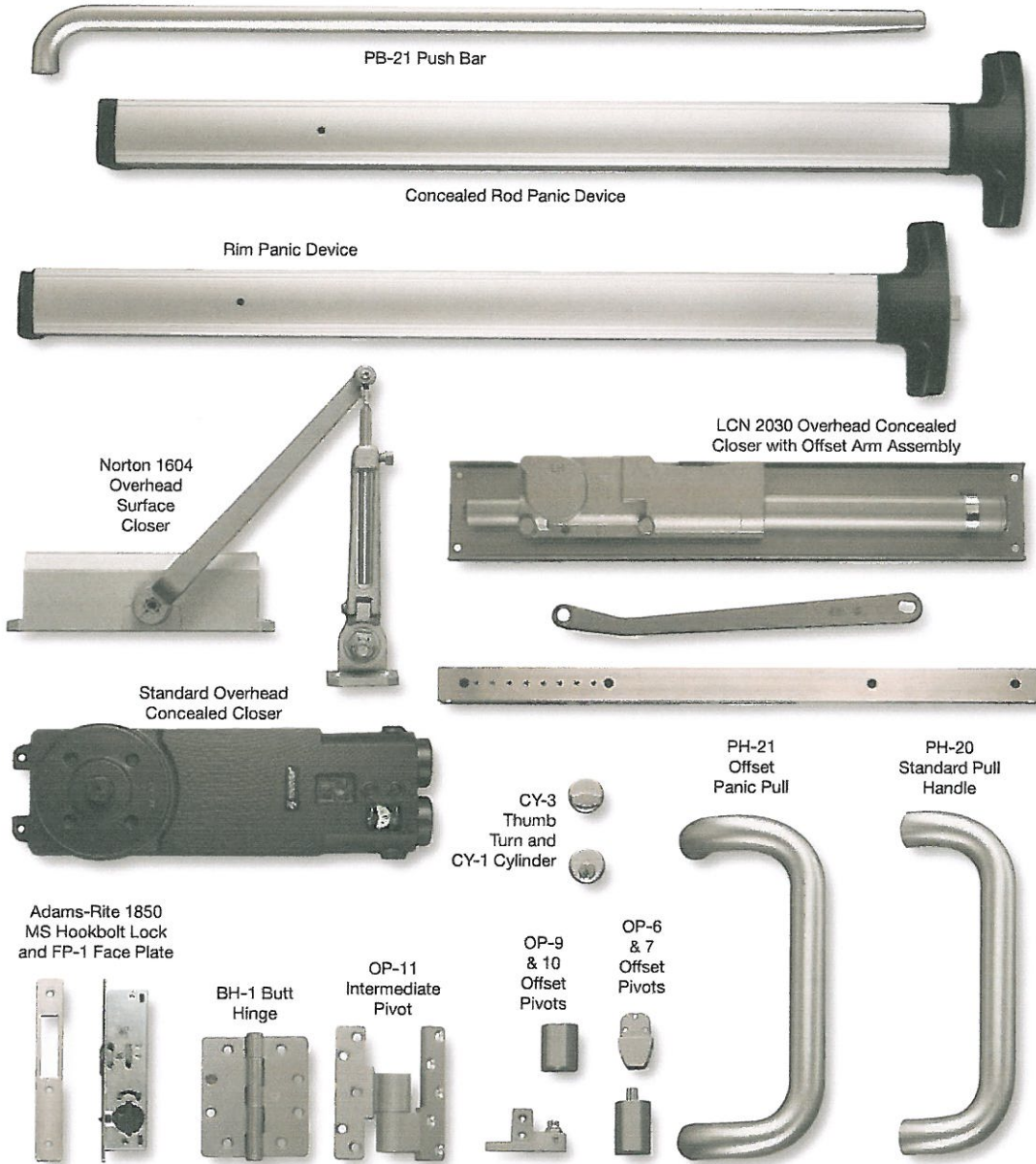



Architectural Testing

## ENTRY DOOR TEST REPORT

Rendered to:

The Vistawall Group

**Product: Single 212 Narrow Stile Outswing  
Full-Lite Aluminum Entry Door  
w/ Standard TH-43 Threshold  
and Woolpile Weathering**

<b>Title</b>	<b>Summary of Results</b>
Air Infiltration@ 1.57psf	0.58 cfm/ft
Air Infiltration@ 6.24 psf	1.46 cfm/ft

**Report No: 52590.02-801-47**

**Test Date: 07/28/04**

**Report Date: 08/10/04**

2865 Market Loop, Suite B  
Southlake, Texas 76092  
phone: 817-410-7202  
fax: 817-424-8463  
www.archtest.com

**ENTRY DOOR TEST REPORT**

**Rendered to:**

**The Vistawall Group  
803 Airport Road  
Terrell, TX 75160**

**Report No: 52590.02-801-47  
Test Date: 07/28/04  
Report Date: 08/10/04**

**Project Summary:** Architectural Testing, Inc. (ATI) was contracted by The Vistawall Group to witness tests in Terrell, TX on a 212 Narrow Stile outswing full-lite aluminum entry door with TH-43 threshold and woolpile weathering.

**Test Specification:** The test specimen was evaluated in accordance with the following:

ASTM E283-91(1999), Standard Test Method for Determining the Rate of Air Leakage Through Exterior Windows, Curtain Walls, and Doors Under Specified Pressure Differences Across the Specimen.

**Test Specimen Description:**

**Series/Model:** 212 Narrow Stile Door

**Type:** Outswing full-lite aluminum entry door

**Overall Size:** 40" wide by 86" high.

**Door Leaf Size:** 36" x 84"

**Configuration:** X

**Overall Area:** 23.89 ft<sup>2</sup>, with 20 linear feet of crack.

**Glass Opening Size:** 30-1/2" x 76"

**Glazing Type:** Single glazed using one piece of nominal 1/4" tempered monolithic glass.

**Glazing Details:** The glass was set into the opening and secured using interior and exterior snap-in aluminum glazing beads with included EPDM gaskets.

**Weatherstripping:**

<u>Description</u>	<u>Quantity</u>	<u>Location</u>
WP084 woolpile	1 row	Frame head and jambs
D-120 door sweep	1	Door leaf bottom rail

**Frame Construction:** All frame members were formed from extruded aluminum. The head was secured to the jambs using two #14 x 1" screws. The TH-43 threshold is attached to the jambs using an extruded aluminum clip secured with two #8 x 1-1/2" screws into each member.

**Door Leaf Construction:** All door leaf members were formed from extruded aluminum. Extruded aluminum corner blocks were attached to the top and bottom of the stiles with one 1/4"-20 x 1" bolt. The top and bottom rails were secured to the stiles through the corner blocks using two #10 x 3/4" screws. The rails were then welded to the stiles.

**Hardware:**

<u>Description</u>	<u>Quantity</u>	<u>Location</u>
Offset pivot hinges	1	Top and bottom of the hinge stile (2 total)
Hook-bolt lockset	1	Midpoint of the lock stile
Exterior pull handle	1	Door leaf lock stile
Interior push bar	1	Interior side of door panel

**Sealant:** Threshold sealed to the jambs with sealant.

**Installation:** The unit was installed into a wood test chamber and secured using #12 x 2-1/2" screws as follows: one 6" from each corner in the head (2 total); and one 4" from each corner and at the midpoint in the sill (3 total). The perimeter of the frame was sealed to the chamber with sealant.

**Test Results:**

<u>Title of Test</u>	<u>Results</u>
Air infiltration (ASTM E283-91 (1999)) @ 1.57 psf	0.58 cfm/ft
Air infiltration (ASTM E283-91 (1999)) @ 6.24 psf	1.46 cfm/ft

Detailed drawings and a copy of this report will be retained by ATI for a period of four years. This report is the exclusive property of the client so named herein and is applicable to the sample tested. Results obtained are tested values and do not constitute an opinion or endorsement by this laboratory. This report may not be reproduced except in full without approval of Architectural Testing.

For ARCHITECTURAL TESTING, INC:

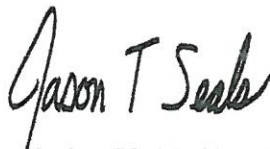

Digitally Signed for: Jason T. Seals by John H. Waskow

---

Jason T. Seals  
Technician

JTS:jts/pd  
52590.02-801-47-R0



Digitally Signed for: Andy Cost by John H. Waskow

---

Andy B. Cost  
Laboratory Manager

**Revision Log**

<u>Rev. #</u>	<u>Date</u>	<u>Page(s)</u>	<u>Revision(s)</u>
0	08/10/04	N/A	Original report issue

**Exhibit B**  
**Campaign Disclosure Certificate**

The Campaign Disclosure Certificate is required pursuant to the Village of Downers Grove Council Policy on Ethical Standards and is applicable to those campaign contributions made to any member of the Village Council.

Said Campaign Disclosure Certificate requires any individual or entity that is a party to a contract with the Village to disclose campaign contributions, as defined in Section 9-1.4 of the Election Code (10 ILCS 5/9-1.4), made to current members of the Village Council within the five (5) year period preceding the date of the contract.

By signing the contract, Applicant agrees to refrain from making any campaign contributions as defined in Section 9-1.4 of the Election Code (10 ILCS 5/9-1.4) to any Village Council member and any challengers seeking to serve as a member of the Downers Grove Village Council.

\_\_\_\_\_  
Under penalty of perjury, I declare:

Applicant has not contributed to any elected Village position within the last five (5) years.

Gus Tzoumas  
Signature

GUS TZOUMAS  
Print Name

Applicant has contributed a campaign contribution to a current member of the Village Council within the last five (5) years.

Print the following information:

Name of Contributor: \_\_\_\_\_  
(company or individual)

To whom contribution was made: \_\_\_\_\_

Year contribution made: \_\_\_\_\_ Amount: \$ \_\_\_\_\_

\_\_\_\_\_  
Signature

\_\_\_\_\_  
Print Name

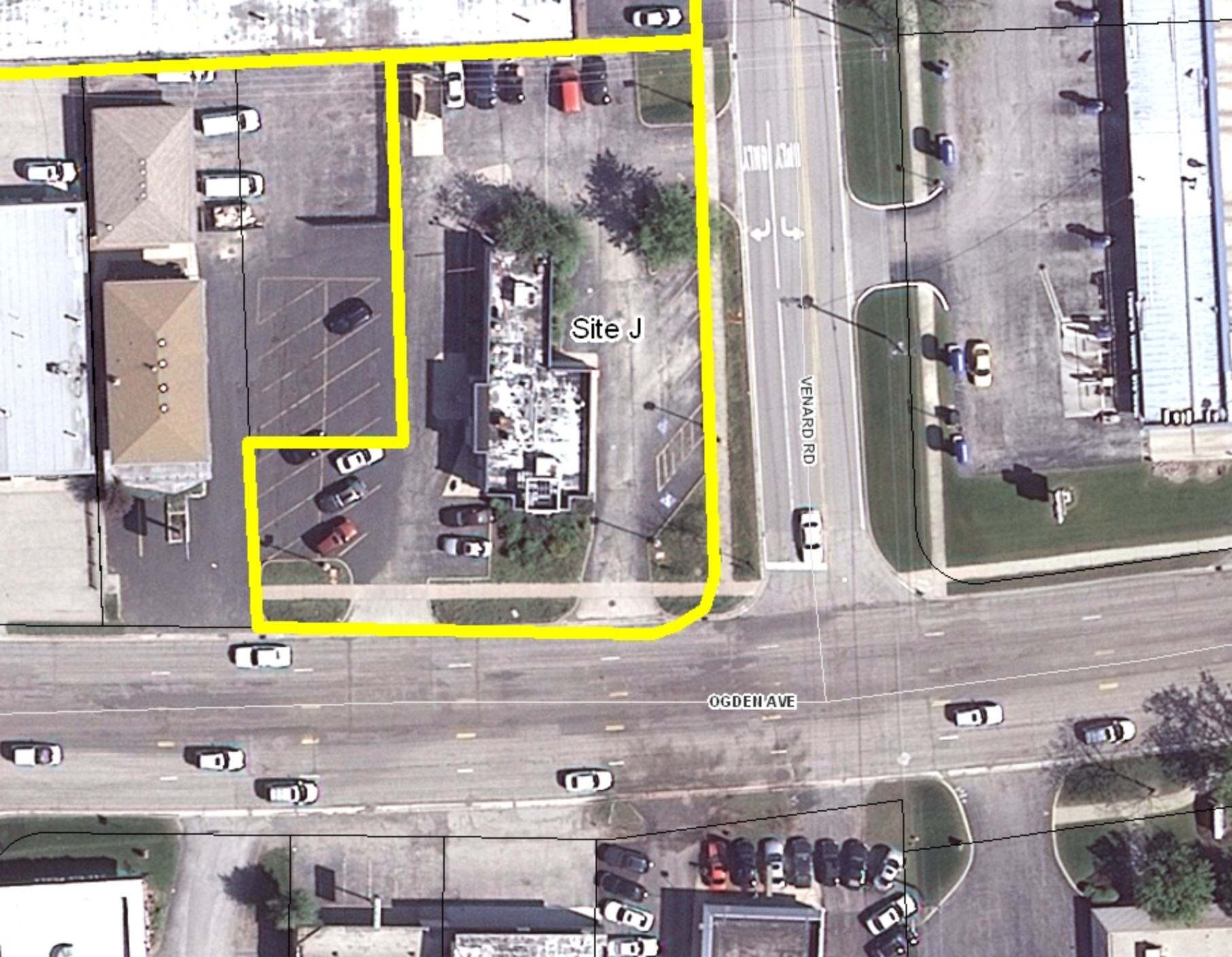

Site J

VENARD RD

OGDEN AVE



September 2, 2011

Gus Tzoumas, President  
GDT Properties, Inc.  
6339 West 26<sup>th</sup> Street  
Berwyn, IL 60402

**Re: OASIS Grant for 1322 Ogden Avenue (Mr. Submarine)**

**COMMUNITY RESPONSE  
CENTER**

630.434.CALL (2255)

**CIVIC CENTER**

801 Burlington Avenue  
Downers Grove  
Illinois 60515-4782  
630.434.5500  
TDD 630.434.5511  
FAX 630.434.5571

**FIRE DEPARTMENT**

**ADMINISTRATION**  
5420 Main Street  
Downers Grove  
Illinois 60515-4834  
630.434.5980  
FAX 630.434.5998

**POLICE DEPARTMENT**

825 Burlington Avenue  
Downers Grove  
Illinois 60515-4783  
630.434.5600  
FAX 630.434.5690

**PUBLIC WORKS**

**DEPARTMENT**  
5101 Walnut Avenue  
Downers Grove  
Illinois 60515-4046  
630.434.5460  
FAX 630.434.5495

Dear Mr. Tzoumas:

Thank you for your interest in the Ogden Avenue Site Improvement Strategy (OASIS) Program. The OASIS Team met on August 29, 2011 to review your application for a matching grant to make façade, landscaping, sign and other site improvements at the above-mentioned property.

The OASIS Team is pleased to inform you that the request is being recommended for funding. The OASIS Team is recommending an extra 25% for the comprehensive nature of these improvements. As such, the recommended grant amount is \$48,621.88. Because the request is more than \$15,000, the recommendation of the OASIS Team will be forwarded to the Village Council with the following conditions:

1. Details for the proposed sign, including electrical, foundation and location must be provided prior to issuance of permit. Sign must be at least 10 feet from south and east property lines and 25 feet from west property line.
2. An engineer/architect's stamp must be provided for the foundation drawing.

Village staff anticipates Village Council consideration of the OASIS Grant will take place on or before September 20, 2011.

Please note, pursuant to the State of Illinois Labor Laws, the project must use prevailing wage labor.

Please contact me if you have any comments or questions. I can be reached at 630.434.5520 or [jobrien@downers.us](mailto:jobrien@downers.us).

Sincerely,  
The OASIS Team

Jeff O'Brien, AICP  
Planning Manager  
Village of Downers Grove



**Village of Downers Grove**

**Official Village Policy Approved by Village Council**

Description: **Ogden Avenue Site Improvement Strategy Program**

Res. or Ord. #: **Ord. 5150**

Effective Date: **09/14/10**

Category: **Planning & Community Development**

New Council Policy

Amends Previous Policy Dated: \_\_\_\_\_

Description of Previous Policy (if different from above):  
\_\_\_\_\_

**ORDINANCE NO. 5150**

**AN ORDINANCE ADOPTING AN OGDEN AVENUE  
SITE IMPROVEMENT STRATEGY PROGRAM**

WHEREAS, the Village has the authority, pursuant to the laws of the State of Illinois, to promote the health, safety, and welfare of the Village and its inhabitants, to prevent the spread of blight, to encourage private development in order to enhance the local tax base, to increase employment, and to enter into contractual agreements with third parties for the purpose of achieving these purposes.

WHEREAS, the Village is authorized under the provisions of the Tax Increment Allocation Redevelopment Act, 65 ILCS 5/11-74.4-1, *et seq.*, as amended (the "TIF Act"), to finance redevelopment in accordance with the conditions and requirements set forth in the TIF Act.

WHEREAS, to stimulate and induce redevelopment pursuant to the TIF Act, the Village has, after giving all notices required by law and after conducting all public hearings required by law, adopted the following ordinances:

1. Ordinance No. 4247, adopted February 6, 2001, titled "*An Ordinance Approving the Ogden Avenue Corridor Redevelopment Plan and Project*" (the "Redevelopment Plan");
2. Ordinance No. 4248 adopted February 6, 2001, titled "*An Ordinance Designating the Ogden Avenue Corridor Redevelopment Project Area*";
3. Ordinance No. 4249, adopted February 6, 2001, titled "*An Ordinance Adopting Tax Increment Financing for the Village of Downers Grove*".

WHEREAS, in an effort to promote revitalization of the Ogden Avenue commercial corridor the Village wishes to establish the Ogden Avenue Site Improvement Strategy Program ("OASIS Program");

WHEREAS, the OASIS Program is made available to provide a significant impact on the exterior of properties, thus improving the economic vitality of the Ogden Avenue commercial corridor;

WHEREAS, the goals of the OASIS Program are to provide financial assistance to property and business owners in order to provide more attractive sites, improve traffic circulation for vehicles and pedestrians, improve existing building appearance, and improve signage, in accordance with the Ogden Avenue Commercial Corridor Master Plan and the Village's Strategic Plan;

NOW, THEREFORE, BE IT ORDAINED by the Council of the Village of Downers Grove, DuPage County, Illinois, as follows:

**ELIGIBLE PROJECTS:**

**A. SITE IMPROVEMENT**

1. Lighting Fixtures, Fencing, utility burial

- This includes installation of exterior lighting fixtures which are associated with a building façade or within a parking area. Decorative fencing around parking areas, adjacent properties and refuse screening are also included in this category and sidewalks.
- The burying of overhead power lines, telephone lines or other above-grade utilities.

2. Access Consolidation, Cross Access, or Pedestrian Improvement

- This includes driveway consolidation on Ogden Avenue, cross access between businesses, and installation of pedestrian walkways and sidewalks.

3. Stormwater

- This includes the installation of detention area or best management practices.

**B. LANDSCAPE IMPROVEMENT**

1. Landscaping

- This includes the installation or replacement of new landscaping and green space to comply with current ordinance requirements.

2. Stormwater

- This includes the installation of detention area or best management practices.

**C. FAÇADE IMPROVEMENT**

1. Exterior Woodwork and Architectural Materials

- This includes improvement or repair, cleaning, refinishing, restoring, or replacement of exterior woodwork or architectural materials.

2. Masonry

- This includes masonry improvements, repairs, restoration or tuckpointing.

3. Windows and Doors

- This includes the replacement, installation or restoration of windows (including display, ornamental, upper-story and storm windows) and exterior doors.

4. Cornices, Parapets, Awnings, Canopies and Roofs

- This includes the installation or repair of cornices, parapets, awnings, canopies or roofs when part of the facade renovation; or independently, when it is a visible part of the façade from Ogden Avenue or required by Village ordinance to screen rooftop mechanical units and vent stacks.

**D. SIGNAGE IMPROVEMENT**

1. Signs

This includes the installation or replacement of signs to comply with current Village ordinances.

2. Financial Assistance: Property owners and business owners (“Owners”) located within the Ogden Avenue TIF District may be eligible for a grant award from the Village for up to fifty percent (50%) of the total cost of the work for certain improvements made to their buildings or property in accordance with the following guidelines:

a) Interior Parcels less than 1 acre

Type of Project	Eligible for a Grant Award up to 50% of the Cost of Work (up to the maximum noted herein) The total maximum award shall not exceed \$50,000
Signage Improvement - coordinated for retail center or monument sign	\$2,500 for parcels less than 100 ft. wide; \$5,000 for parcels between 100 ft. and 259 ft. wide; \$7,500 for parcels 260 ft. wide or greater
Wall Signage for Single Tenant (only for business that were in operation before May 2005)	\$3,000
Landscape improvement	\$20,000
Site improvement	\$20,000
Façade improvement	\$10,000

b) Corner Parcels or Parcels Greater than 1 Acre or individual Tenant Spaces in Excess of 5,000 sq. ft.

Type of Project	Eligible for a Grant Award up to 50% of Work (up to the maximum noted herein) The total maximum award shall not exceed \$75,000
Signage Improvement - coordinated for retail center or monument sign	\$7,500
Wall Signage for Single Tenant (only for business that were in operation before May 2005)	\$3,000
Landscape improvement	\$40,000
Site improvement	\$40,000
Façade improvement	\$15,000

c. Conditions:

1. Only exterior improvements to properties and buildings as described above will be eligible for a grant award. Internal elements will not be eligible. Generally, exterior maintenance (e.g.

painting, parking lot resurfacing, seal-coating, replacing dead landscaping, etc.) will not be considered; however, in some cases maintenance may be eligible if it is an essential component of a project and is a permanent improvement to the property (e.g. tuck-pointing, replacing windows and doors).

2. Improvements to buildings, parking lots and uses which do not meet current zoning requirements will not be eligible.
3. Improvements requiring zoning variations may be eligible for project funding; however, no part of the zoning variation process will be funded.
4. A bonus of 25% of the maximum grant award amount for particular project categories may be provided for projects combining multiple categories. For example, a 10,000 square foot tenant on a 1.5-acre lot proposing landscape improvements and façade improvements would be eligible for up to \$68,750 ( $\$40,000 \times 1.25 + \$15,000 \times 1.25$ ) assuming a total project cost of \$137,500.
5. For single tenants in multi-tenant buildings, the maximum grant award for the tenant will be limited by the percentage of space the tenant occupies in the building. For example, if a tenant occupies 25% of a building on a parcel less than 1 acre in size, the maximum façade improvement grant award would be \$2,500.

3. **Sidewalk Easement or Construction Required as a Pre-Condition:**

In order to promote the Ogden Avenue Master Plan, and prior to receipt of any grant award, the applicant must either grant a sidewalk easement approved in a form acceptable to the Village and receive an additional \$1,000 of grant funds and/or install a sidewalk on the property along Ogden Avenue and receive an additional 50% of grant funds for the cost of the installation.

4. **Procedures:**

The OASIS Team will evaluate all submittals. The OASIS Team is comprised of Village staff, Economic Development Corporation representatives and Downers Grove Area Chamber of Commerce and Industry representatives. Only complete applications will be evaluated by the review team. Projects will be evaluated on a qualitative basis and will be evaluated against one another. The intent of the initiative is to encourage comprehensive development in the TIF district. One or more application deadlines will be established by the Village.

*1. Pre-Application Meeting (OPTIONAL)*

Prior to making a formal application, the prospective applicant is encouraged to meet with the OASIS Team. During this meeting, the prospective applicant is familiarized with the program and the application process. A general discussion of needs and ideas of all parties, design alternatives and general cost parameters will be discussed. An application packet may be obtained at this time, as well as, information about the *Ogden Avenue Master Plan*.

*2. Complete and Submit Application*

The first round of applications should be completed and submitted to the Community Development Department by an established due date included in the application packet. The OASIS Team will review the application for completeness within 10 working days of application deadline.

*3. Approval of Project by the Village*

Within 30 days of the application deadline, the OASIS Team will meet to review and rank the complete grant applications against each other in order to establish an order of merit. By ranking projects the OASIS Team will recommend funding of the highest ranked projects first. The OASIS Team will utilize the review criteria included in the application packet to rank applications. Recommendations from the OASIS Team will be forwarded to the Village Manager for consideration. Grant awards recommended by the OASIS Team less than \$15,000 may be authorized by Village Manager; however, grant awards in excess of \$15,000 must be authorized by the Village Council.

#### *4. Execution of the Site Improvement Reimbursement Grant Agreement*

In conjunction with the award of the grant, the applicant will be required to enter into a Site Improvement Reimbursement Grant Agreement with the Village specifying the responsibility of the grant recipient. This agreement must be completed prior to the commencement of funded improvements. A typical agreement will reimburse the applicant, up to the agreed upon maximum, with the submittal of cancelled checks and final inspection.

#### *5. Begin Work*

After the Site Improvement Reimbursement Grant Agreement has been executed, a "Letter of Approval and Notice to Proceed" will be sent to the applicant from the Community Development Department, including an estimate of the total grant amount the applicant is eligible to receive once work is completed and cancelled checks for said eligible work have been received.

The applicant may begin work once all necessary permits have been issued. Prior to, or during construction, any on-the-job changes to the approved design must be reviewed and approved by the OASIS team and the Community Development Department. If changes involve permit related work, the Community Development department must also review and approve the change.

#### *6. Complete of the Project*

Upon completion of the project, the work is to be approved by an inspector(s) in the appropriate departments for compliance with the original design drawings, including any approved on-the-job changes and Village ordinances. In the event the Village finds the finished work product does not meet ordinance requirements or is not consistent with the approved grant application and any approved on-the-job changes, the Village will not be obligated to provide reimbursement for any of the work completed.

#### *7. Payment of the Grant*

Once the grant recipient receives final approval, he/she shall provide a request for reimbursement and all receipts (including copies of cancelled checks) for grant eligible work to the Community Development Department. The Village of Downers Grove will provide reimbursement up to the agreed upon maximum after eligible grant work has been inspected and certified as to its completion and compliance with the approved grant application.

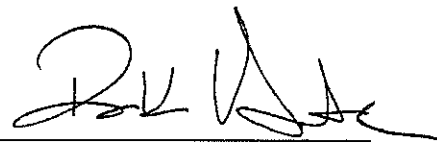

Ronald L. Sandack, Mayor

Passed: September 14, 2010

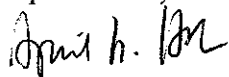
Attest:   
April K. Holden, Village Clerk

# OASIS Grant Overall Site Map

- Site A: Bill Kay Nissan (1601 Ogden)
- Site B: DG Animal Hospital (631-635 Ogden)
- Site C: 4232 Venard Road (WITHDRAWN)
- Site D: A-Len Radiators (333 Ogden)
- Site E: Forn Parts/Sparomobile (501-503 Ogden)
- Site F: 946 Ogden Office Building
- Site G: 1614 Ogden Apartment Building
- Site H: 1602 Ogden Apartment Building
- Site I: Prestige Liquors (739 Ogden)
- Site J: Mr. Submarine (1322 Ogden)

