

## COUNCIL WORKSHOP ITEM

<b>ITEM:</b>	VILLAGE OF DOWNERS GROVE PARKING FACILITY PROJECT #14-00		
<b>DATE:</b>	June 14, 2004		
<b>PREPARED BY:</b>	David H. Barber, P.E. - Director of Public Works Michael D. Millette, P.E. – Assistant Director of Public Works Brian Parks, Senior Staff Engineer - Public Works		
<b>PURPOSE:</b>	To authorize execution of contract Change Order #12 for the Village of Downers Grove Parking Facility, Project #14-00		
<b>BASE BID AMOUNT:</b>	<b>\$11,486,390.00</b>	<b>ACCOUNT:</b>	107.541.0000.5805
<b>BUDGET AMOUNT:</b>	<b>\$12,500,000.00</b>		

**DISCUSSION:**

As part of the ongoing Parking Deck construction, the attached Change Order is submitted for approval based on extra work and changes in the contract documents. The Change Order falls into three general categories: item correction errors, items related to changed conditions, and items to enhance the facility. They come from two sources: those initiated by the Owner, and those initiated by the Contractor. Each item is categorized by type and initiating entity.

Change Order #12 is as follows:

Items A through H:

- A. Additional Water Main and Sanitary Sewer (Change, Con, Owner)-----\$14,991.00
- B. Repair of 12” storm sewer damaged by NiCor Gas (Corr, Owner)-----\$600.00
- C. Changing 12” RCP to 12” ductile iron pipe (Enhance, Owner)-----\$4,453.00
- D. Curtiss St. Landscape Median Revisions (Enhance, Owner)-----\$15,632.00
- E. Install site lighting along entrance drives & sidewalks (Enhance, Owner)-----\$124,191.00
- F. Additional Labor & Equipment to install 36” RCP outlet (Corr, Owner)-----\$35,025.00
- G. Credit for unused balance of hardware allowance (Change, Con)-----(\$161.00)
- H. Modify storm sewer structure to conform to submittal (Corr, Owner)-----\$1,806.00

**Total #12 Change Order Request-----\$196,537.00**

**ATTACHMENTS:**

Change Order No. 12

**RECOMMENDATION:**

Staff recommends authorization and execution of contract Change Order #12 for the Village of Downers Grove Parking Facility in the amount of \$196,537.00 on the June 22, 2004 Workshop Agenda.

Funding for this Change Order is in the TIF Fund, account # 107.541.0000.5805.



## Change Order No. 012

**Date:** 26 May 2004

**Subject:** Various

**Reference:** COR No.'s 036, 037, 039, 040, 041, 043, 044, 047

CCD's No. 041, 048, 053

---

The following is hereby agreed upon as a change in the Agreement between the Village of Downers Grove and Turner Construction Company for construction of the Village of Downers Grove Parking Facility, as provided for in Article 7.2 of the General Conditions of the Contract:

### **Description of Change in the Work:**

- A. Provide and install the additional water main and sanitary sewer under the Curtiss Street entrance, as shown on the attached sketch and materials list, issued with Construction Change Directive 048.
- B. Repair in kind the 12" PVC storm sewer on the west side of the site that was damaged by Nicor.
- C. Provide and install 12" ductile iron pipe instead of 12" reinforced concrete pipe for P18, P19, P2 and P4.
- D. Incorporate into the Contract Documents the revisions to the Curtiss Street entrance drive, as shown on the attached sketches, Exhibits A and B, and as described in the attached scope of work and materials list, issued with Construction Change Directive 053. The revisions provide for a landscaped median.
- E. Install site lighting along entrance drives & sidewalks.
- F. Additional Labor & Equipment to install 36" RCP outlet.
- G. Credit for unused balance of hardware allowance.
- H. Modify storm sewer structure to conform to submittal.

### **Reason for Change in the Work:**

- A. The additional utilities provide for service to a planned redevelopment of the property at 939 Curtiss (formerly Hart's Garage). The Village prefers to add this work to the current project to avoid the possibility of having to trench through new sidewalk and pavement in the near future.
- B. The storm sewer was recently installed and its location was unknown to Nicor.

- C. Ductile iron pipe is stronger than the specified reinforced concrete pipe and will be better able to withstand traffic above, especially the cranes to be used during construction to set the precast panels.
- D. The revisions shown are being considered as an upgrade to the Curtiss Street entrance drive.
- E. The revisions shown are being considered as an upgrade to the Parking Deck because the original plans were incomplete with respect to site lighting.
- F. The installation of this pipe could not be done as planned, before the second level deck was in place, do to discovery of fuel-impacted soil in the area.
- G. An allowance of \$12,000.00 was included in the Contract for purchase of door hardware. The hardware was purchased at a cost of \$11,839.00. A credit of \$161.00 is due the Village.
- H. Submittal 070-R1 was reviewed and returned by C.M. Lavoie stamped "Approved". After the structure was installed, questions were raised about how the clean-out holes could function. Upon reviewing the previously returned drawing, errors were found and a corrected mark-up was provided. Because the correction was made after the approved structure was installed, costs were incurred to make the modifications in the field.

**Construction Schedule Adjustment:**

Calendar days added or subtracted (+ or -): 0

Revised date of substantial completion: \_\_\_\_\_

**Construction Cost Adjustment:**

Cost or credit amount (+ or -):	A.	\$14,991.00
	B.	\$600.00
	C.	\$4,453.00
	D.	\$15,632.00
	E.	\$124,191.00
	F.	\$35,025.00
	G.	(\$161.00)
	H.	\$1,806.00
Net cost adjustment:		\$196,537.00

Revised amount \* of Contract Sum: \$12,043,410.00

\* May not include adjustments for all other pending or recently signed Change Orders.

	Position	Date
Village of Downer's Grove Representative		

	Position	Date
Turner Construction Company Representative		

# Turner

**Turner Construction Company**  
945 Curtiss Street  
Downers Grove, Illinois 60515  
phone: 630.663.0431  
fax: 630.663.0415

Wednesday, June 09, 2004

Ms. Sara Davis  
Alfred Benesch & Company  
5202 Washington Ave. Suite No. 9  
Downers Grove, IL 60515

RE: Downers Grove Parking Deck  
945 Curtiss St. Downers Grove. IL 60515  
Project #: 9252  
Change Order Request Number 037 (REV 1)

Dear Ms. Davis,

We have finalized the required quotations for PCO number 067 for the following extra work CCD No. 041: Plan Revision, Site Lighting. We have reviewed the scopes of work and have verified that they are in compliance with our contract agreement. The following is a detailed itemization of all extra costs:

Item	Description	Amount Proposed	Contractor
001	CCD No. 041: Plan Revision, Site Lighting	\$110,250.00	MAYELE
002	Turner Overhead & Profit - 5.0%	\$5,512.00	TURCON
003	CCIP Workmen Comp - 3.35%	\$3,693.00	TURCON
004	CCIP Liability - 1.55%	\$1,709.00	TURCON
005	SubGuard - Bond - 1.0%	\$1,102.00	TURCON
006	Turner Bond - 0.75%	\$826.00	TURCON
007	CCIP & Bond Maru Up - 15%	\$1,099.00	TURCON

**Total Amount            \$124,191.00**

See the attached for a detailed breakdown of the costs included in this Change Order Request.

**RECEIVED**  
JUN 09 2004  
BY: *[Signature]*

Per our phone call this afternoon, due to the lead times involved in procuring material, in particular the street lights, it is important to receive approval of the cost noted above, so as to minimize the impact to the project schedule. It is understood that Turner is reserving our right to submit for a time extension after final analysis of the submittal and approval process.

Please return one (1) copy of this letter indicating your approval of this Turner Change Order which increases our Contract by One hundred twenty four thousand one hundred ninety one and 00/100 (\$124,191.00). This approval will also authorize us to issue Subcontract Change Orders as listed on attachment.

Sincerely,



Mel Cramm  
Project Manager

Approved By: \_\_\_\_\_ Date: \_\_\_\_\_  
Sara Davis  
Project Manager

cc: File



# MAYER ELECTRICAL CONTRACTING, INC.

P.O. BOX 8113  
BARTLETT, IL 60103

Facsimile: 630-289-6432

Telephone: 630-289-0200

May 4, 2004

Turner Construction Company  
945 Curtiss Street  
Downers Grove, IL 60515  
Attn: Mel Cramm

RE: RFP NUMBER; PCO-067

Dear Mel,

Please find the following information in relation to PCO-067.

**CCD NO. 041: PLAN REVISION, SITE LIGHTING.**

Cost Breakdown:

Labor	\$ 40,905.00 / \$52.85 per man hour	<u>Labor hours: 774 hrs.</u>
Sub-Subcontractor / Trench-It	\$ 15,332.00	
Equipment	\$ 35,067.00	
Materials		
Sub Total	\$ 91,304.00	
Overhead Profit @ 15%	\$ 13,696.00	
<b>SUB TOTAL:</b>	<b>\$105,000.00</b>	
Mayer		
Overhead Profit @ 5%	\$ 5,250.00	
<b>TOTAL:</b>	<b>\$110,250.00</b>	

Extension of time of 2 ½ weeks.

VM/gm  
tcpco-067.file



APRIL 12 2004  
MAYER ELECTRIC  
VINCE MAYER

WE ARE PLEASED TO QUOTE ON THE FOLLOWING PROJECT  
**DOWNERS GROVE PARKING STRUCTURE STREET LIGHTING**

Trench-It, Inc. is pleased to quote the electrical work as shown on CE-100, CE-002 and CE-003 dated 03/04/04 by Christopher B. Burke Eng. Ltd.

Our Price For This work shall be: **\$105,000.00**

**(ONE HUNDRED FIVE THOUSAND DOLLARS )**

Scope of Work Includes:

1. Trench and install uniduct conduit systems as shown on drawing CE-001
2. Backfill with CA-7 stone under all paved or concrete areas.
3. Receive, assemble and set (23) customer supplied light pole assemblies.
4. Furnish and install (23)-2ft Dia. x 6ft Deep concrete bases as shown on drawing CE-002.
5. Furnish and install (23) rebar cages as shown on drawing CE-002.
6. Furnish and install (23) gfi receptacle assemblies as shown on drawing CE-002.
7. Furnish and install (4) 60 amp twistlock assemblies shown on drawing CE-002.
8. Furnish and install (5) handholes as shown on drawings CE-001 & CE-002.
9. Trench and install (3) sets of sleeves across the drives as shown on drawing CE-001.
10. Rework conduit sleeves and wire on Curtiss Street as shown on CE-001.
11. Demo (1) light pole and return to the Village as shown on drawing CE-001.
12. Demo (1) concrete base as shown on drawing CE-001.
13. Bore across Curtiss with (2)- 2" GRC conduit sleeves as shown on CE-001.
14. Bore from Curtiss handhole to the light controller as shown on CE-001.
15. Connect the New Street Lighting feeds to Light controller as shown on drawing CE-001 and CE-003

Trench-It, Inc. 549 W. Sheridan Road, McHenry, IL 60050  
815-344-5550 - Fax: 815-344-9836

PAGE 2

DOWNERS GROVE PARKING STRUCTURE  
STREET LIGHTING IMPROVEMENTS

EXCLUSIONS / QUALIFICATIONS

1. Permits fees, inspection fees, and utility company fees.
2. Premium time.
3. Any and all landscape restorations.
4. Dependency on W.B.E. certification is not part of this proposal.
5. Minority participation and/or city residency is not part of this proposal.
6. Normal material and labor escalations of up to 3% per year maximum have been included.
7. Any tree removal.
8. Demolition to building structures, fences, ect.
9. Situations dealing with contaminated spoils.
10. Concrete equipment pads for (distribution equipment, generators, ect.).
11. Excludes foundation/wall coring or sleeves.
12. Private utility locates.
13. Damage caused by others.
14. Excavation of underground obstructions (boulders, foundations, walls, ect.)
15. Relocation of work due to conflicts with other utilities will be performed only upon written orders.
16. Demolition of any kind, Saw Cutting, Concrete removal, Blacktop Removal.
17. Unless otherwise noted herein this proposal is based upon completing entire scope of work in one operation. De-mobilization and or Re-mobilization will be charged accordingly (\$1,500.00 PER).
18. This job is figured to be tax exempt.

Trench-It, Inc. 549 W. Sheridan Road, McHenry, IL 60050  
815-344-5550 - Fax: 815-344-9836

PAGE 3

**DOWNERS GROVE PARKING STRUCTURE  
STREET LIGHTING IMPROVEMENTS**

TERMS

All material is guaranteed to be as is specified. All work shall be performed in a workmanship like manner according to standard practices. All field personnel shall be union members. Any alteration from the original plans and specifications, as outlined in this proposal will be executed upon written orders only. All fieldwork orders and/or change orders shall be executed prior to the performance of the work. All signatures of work orders and change orders acceptance will constitute acceptance of the outlined scope and confirm and guarantee payment in the amount as shown over and above the original accepted contract/proposal amount. Field production will progress contingent upon strikes, weather conditions, uncontrollable shortages of material and all other delays beyond the control of Trench-It. Production delays, caused by the performance of other trades, shall not constitute reasons for Trench-It to work overtime to maintain the job progress schedule. No overtime has been included in this proposal except as noted in the inclusions/exclusions. It is understood that the owner or their agents, shall carry fire, tornado, and other pertinent insurance coverage. Trench-It shall provide certificates of insurance for all required insurances including workman's compensation. All Trench-It supervisors and field personnel have completed required OSHA sanctioned courses. Trench-It is a certified WBE Contractor. All private utilities and underground services will be located by others and will not be warranted by Trench-It. Site obstructions precipitating progress delays will be charged accordingly. All payments to Trench-It, unless otherwise specified, are due net thirty (30) days from invoice date. This proposal is subject to escalation after forty-five (45) days from date herein.

If you should have any further questions regarding this proposal, please do not hesitate to contact me.

Sincerely,

TRENCH-IT CORPORATION

  
BOB ROLEWICZ

ACCEPTANCE: \_\_\_\_\_

PRINT NAME: \_\_\_\_\_

DATE: \_\_\_\_\_

Trench-It, Inc. 549 W. Sheridan Road, McHenry, IL 60050  
815-344-5550 - Fax: 815-344-9836



# VILLAGE OF DOWNERS GROVE PARKING FACILITY

Project No. 14-00

## Construction Change Directive No. 041

Date: 16 March 2004

To: John Doherty, Turner Construction Company

Subject: Plan Revision, Site Lighting

Turner Construction Company (Contractor) is hereby directed by the Village of Downers Grove, as provided or in Article 7.3 of the General Conditions of the Contract, to comply with the following:

**Description:**

Incorporate the attached 3 drawings, CE-001, CE-002 and CE-003 into your contract plan set. These are new drawings and they shall supersede previously issued drawings with respect to site lighting details.

**Reason:**

These drawings have been issued because the original plans were incomplete with respect to site lighting and because some light poles previously shown have been deleted as building-mounted light fixtures were added (CCD 043).

**Expected Construction Schedule Adjustment:**

Extension of \_\_\_ days \*       Reduction of \_\_\_ days \*       None  
 Submit Time Adjustment Proposal \*

**Expected Construction Cost Adjustment:**

Add'l Cost: \$ \_\_\_\_\_ \*       Credit: \$ \_\_\_\_\_ \*       None       Unit Price  
 Submit Cost Adjustment Proposal \*

Please check the appropriate response below and return a signed copy of this document to the Owner's Representative within 5 business days.

- Contractor agrees with the above terms. \*
- Contractor disagrees with the above terms and will submit a Proposal or a Request for Change Order. \*

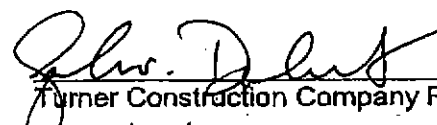
  
 Turner Construction Company Representative  
 3/17/04  
 Date

\* A Change Order will be issued when Owner and Contractor agree upon Schedule and/or Cost adjustments.

Cc: R. Manabat, Desman  
 D. Barber, VDG Public Works  
 M. Millette, VDG Public Works -- Engineering  
 File

  
 Sara L. Davis, PE, SE  
 alfred benesch & company  
 Owner's Representative

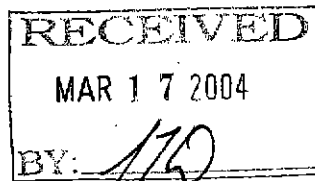



Turner Construction Company  
945 Curtiss Street  
Downers Grove, Illinois 60515  
phone: 630.663.0431  
fax: 630.663.0415

Thursday, May 27, 2004

Ms. Sara Davis  
Alfred Benesch & Company  
5202 Washington Ave. Suite No. 9  
Downers Grove, IL 60515

RE: Downers Grove Parking Deck  
945 Curtiss St. Downers Grove. IL 60515  
Project #: 9252  
Change Order Request Number 041 (REV No. 1)

Dear Ms. Davis,

We have finalized the required quotations for PCO number 064 for the following extra work **Installation of the 36" RCP outlet pipe for the Detention Basin**. We have reviewed the scopes of work and have verified that they are in compliance with our contract agreement. The following is a detailed itemization of all extra costs:

Item	Description	Amount Proposed	Contractor
001	Installation of 36" RCP outlet pipe for the Detention Basin between Grid Lines 1 & 2	\$31,092.00	DAWCOM
002	Turner Overhead & Profit - 5.0%	\$1,555.00	TURCON
003	CCIP Workmen Comp - 3.35%	\$1,042.00	TURCON
004	CCIP Liability - 1.55%	\$482.00	TURCON
005	SubGuard - Bond - 1.0%	\$311.00	TURCON
006	Turner Bond - 0.75%	\$233.00	TURCON
007	CCIP & Bond Markup - 15%	\$310.00	TURCON

**Total Amount \$35,025.00**

We have reviewed the scopes of work and have verified that they are in compliance with our contract agreement. See the attached for a detailed breakdown of the costs included in this Change Order Request.

RECEIVED  
MAY 28 2004  
BY: *[Signature]*

Please return one (1) copy of this letter indicating your approval of this Turner Change Order which increases our Contract by Thirty five thousand twenty five and 00/100 (\$35,025.00). This approval will also authorize us to issue Subcontract Change Orders as listed on attachment.

Sincerely,



Mel Cramm  
Project Manager

Approved By: \_\_\_\_\_ Date: \_\_\_\_\_

Sara Davis  
Project Manager

cc: File



Dawn Companies, Inc.  
 400 S. LaGrange Road  
 Frankfort, IL 60423-1644

# Fax

<b>To:</b>	Mel Cramm	<b>From:</b>	Nancy Lach
<b>Company:</b>	Turner Construction Company (DG)		
<b>Fax:</b>	(630) 663-0415		
<b>Phone:</b>	(630) 663-0431	<b>Date:</b>	05/06/04
<b>Project:</b>	Downers Grove Parking Facility		
<b>Re:</b>	change orders		
<b>Pages:</b>	7		
<input type="checkbox"/> Urgent <input type="checkbox"/> For Review <input type="checkbox"/> Please Comment <input type="checkbox"/> Please Reply <input type="checkbox"/> Please Recycle			

**• Comments:**

Attached are change orders sent to the Village of Downers Grove while we were under contract with them. Now that we're back under contract with Turner, please submit the attached to the owner.

Thank you

400 S. LaGrange Road, Frankfort, IL 60423-1644  
 Phone: (815) 469-5989 Fax: (815) 469-0030

**CHANGE ORDER REQUEST**

Change Order Request #: 23506-0018

Date: 5/6/2004



Project: Downers Grove Parking Facility

Project #: 23506

To: Turner Construction Company (DG)

From: Dawn Companies, Inc.

Attn: Mel Cramm  
945 Curtiss Street  
Downers Grove, IL 60515Nancy Lach  
400 S. LaGrange Road  
Frankfort, IL 60423-1644

Ph.: (630) 663-0431 Fax: (630) 663-0415

Ph.: (815) 469-5989 Fax: (815) 469-0030

We hereby propose to make the following changes:

Install 36" RCP between Column lines 1 &amp; 2 and underneath 2nd floor deck.

Price assumes stair tower footing is on native material and we can excavate to proper elevation without undermining the tower. We have not included close sheeting.

The attached price has taken into account the contracted portion of this work (I have deducted 4 hours). The granular area is the same however it will be produced slower thus causing an elevated cost in the trucking portion.

The existing grade beam will be saw cut and removed by us and replaced by others.

Price also includes removal of the earth retention system installed for teh retainage basin excavation.

Change Order Price	\$31,092.00
Original Contract Amount	\$292,189.00
Previous Executed Change Orders	\$1,950.00

This price is good for 7 days. If conditions change, this price is void.

We are requesting a time extension of 4 days in conjunction with this change.

Nancy Lach

5/6/2004

Author

Date

Accepted The above prices and specifications of this Change Order request are satisfactory and are hereby accepted. All work to be performed under same terms and conditions as specified in original contract unless otherwise specified.

\_\_\_\_\_  
Authorized Signature\_\_\_\_\_  
Date of Acceptance

**CHANGE ORDER REQUEST SUMMARY**

Project: Downers Grove Parking Facility

Change Order Request #: 23506-0018

**Labor**

Labor Type	MHrs	\$/Hr	Burden	Fringe	Tax	Total
Foreman	32	\$55.21	\$0.00	\$0.00	\$0.00	\$1,766.72
Operator	64	\$55.80	\$0.00	\$0.00	\$0.00	\$3,571.20
Laborer	32	\$42.96	\$0.00	\$0.00	\$0.00	\$1,374.72
Plumber	32	\$52.79	\$0.00	\$0.00	\$0.00	\$1,689.28
Design investigation	8	\$75.00	\$0.00	\$0.00	\$0.00	\$600.00
Subtotal						\$9,001.92

**Equipment**

Type	Quantity	Rental Cost	Tax	Total
225 Linkbelt	32	\$79.00	\$0.00	\$2,528.00
963 Caterpillar trac loader	32	\$67.00	\$0.00	\$2,144.00
Semi & Driver (per hour)	127.5	\$78.00	\$0.00	\$9,945.00
Mobilization	1	\$600.00	\$0.00	\$600.00
Trench Box (2 per day)	8	\$200.00	\$0.00	\$1,600.00
Subtotal				\$16,817.00

**Expense**

Expense Type	Quantity	Cost	Tax	Total Cost
Saw cut	1	\$755.00	\$0.00	\$755.00
SubTotal				\$755.00

Total Cost	\$26,573.92
Overhead	\$3,986.09
Warranty	\$531.48
Round	\$0.51
Total	\$31,092.00

# Turner

D.

Turner Construction Company  
945 Curtiss Street  
Downers Grove, Illinois 60515  
phone: 630.663.0431  
fax: 630.663.0415

Saturday, May 29, 2004

Ms. Sara Davis  
Alfred Benesch & Company  
5202 Washington Ave. Suite No. 9  
Downers Grove, IL 60515

RE: Downers Grove Parking Deck  
945 Curtiss St. Downers Grove. IL 60515  
Project #: 9252  
Change Order Request Number 047

Dear Ms. Davis,

We have finalized the required quotations for PCO number 088 for the following extra work **Revisions to Storm Structure No. S29**. We have reviewed the scopes of work and have verified that they are in compliance with our contract agreement. The following is a detailed itemization of all extra costs:

Item	Description	Amount Proposed	Contractor
001	Revisions to Storm Structure S29	\$1,603.00	DAWCOM
002	Turner Overhead & Profit - 5.0%	\$80.00	TURCON
003	CCIP Workmen Comp - 3.35%	\$54.00	TURCON
004	CCIP Liability - 1.55%	\$25.00	TURCON
005	SubGuard - Bond - 1.0%	\$16.00	TURCON
006	Turner Bond - 0.75%	\$12.00	TURCON
007	CCIP & Bond Markup - 15%	\$16.00	TURCON

**Total Amount                    \$1,806.00**

We have reviewed the scopes of work and have verified that they are in compliance with our contract agreement. See the attached for a detailed breakdown of the costs included in this Change Order Request.

Please return one (1) copy of this letter indicating your approval of this Turner Change Order which increases our Contract by One thousand eight hundred six and 00/100 (\$1,806.00). This approval will also authorize us to issue Subcontract Change Orders as listed on attachment.

RECEIVED  
JUN 01 2004  
BY: *[Signature]*

Downers Grove Parking Deck  
Project No. 9252  
PCO No. 088 / COR No. 047

May 29, 2004  
Page 2 of 2

Please return one (1) copy of this letter indicating your approval of this Turner Change Order which increases our Contract by One thousand eight hundred ninety seven and 00/100 (\$1,897.00). This approval will also authorize us to issue Subcontract Change Orders as listed on attachment.

Sincerely,



Mel Cramm  
Project Manager

Approved By: \_\_\_\_\_ Date: \_\_\_\_\_  
Sara Davis  
Project Manager

cc: File

**CHANGE ORDER REQUEST**Change Order Request #: **23506-0023**

Date: 5/24/2004

Project: **Downers Grove Parking Facility**Project #: **23506**To: **Turner Construction Company (DG)**From: **Dawn Companies, Inc.**Attn: **Mel Cramm**  
945 Curtiss Street  
Downers Grove, IL 60515**Nancy Lach**  
400 S. LaGrange Road  
Frankfort, IL 60423-1644

Ph.: (630) 863-0431 Fax: (630) 663-0415

Ph.: (815) 469-5989 Fax: (815) 469-0030

We hereby propose to make the following changes:

reconstruct storm structure S29

revisions were made after approval and installation

Change Order Price	\$1,603.00
Original Contract Amount	\$292,189.00
Previous Executed Change Orders	\$1,950.00

This price is good for 0 days. If conditions change, this price is void.  
We are requesting a time extension of 0 days in conjunction with this change.

Nancy Lach

5/24/2004

Author

Date

Accepted The above prices and specifications of this Change Order request are satisfactory and are hereby accepted. All work to be performed under same terms and conditions as specified in original contract unless otherwise specified.

\_\_\_\_\_  
Authorized Signature\_\_\_\_\_  
Date of Acceptance

**CHANGE ORDER REQUEST SUMMARY**

Project: Downers Grove Parking Facility

Change Order Request #: 23506-0023

**Labor**

Labor Type	MHrs	\$/Hr	Burden	Fringe	Tax	Total
Foreman	8	\$55.21	\$0.00	\$0.00	\$0.00	\$441.68
Laborer	8	\$42.96	\$0.00	\$0.00	\$0.00	\$343.68
Subtotal						\$785.36

**Equipment**

Type	Quantity	Rental Cost	Tax	Total
Air compressor	1	\$125.00	\$0.00	\$125.00
Concrete saw	1	\$50.00	\$0.00	\$50.00
Welding equipment	1	\$50.00	\$0.00	\$50.00
Mini excavator	8	\$45.00	\$0.00	\$360.00
Subtotal				\$585.00

Total Cost	\$1,370.36
Overhead	\$205.55
Warranty	\$27.41
Round	(\$0.32)
<b>Total</b>	<b>\$1,603.00</b>



**FIELD OFFICE FOR PARKING DECK  
CONSTRUCTION  
FAX**

**v: 630.434.6895  
f: 630.434.6896**

**Date:** 29 March 2004

**Number of Pages:** 5  
(Including this cover)

**To:** Nancy Lach, Dawn Companies

**Fax Number:** 815-469-0030

**Cc:** Mike Millette, Brian Parks

630-434-5495

**From:** Sara Davis, Alfred Benesch & Company, Owner's Representative

**Subject:** Storm Sewer Work

---

Nancy,

Per our earlier conversation:

1. The Village would like to you proceed with removing a ten-foot length of RW10 ("grade beam") as shown in the attached sketch, and then installing the 36" discharge pipe P30 and restrictor structure S27 with backhoe and trench box. Replacement of RW10 will be by others. Please provide a cross-section looking north at that location as we discussed, showing extent of excavation near the medical building's concrete stoop.
2. Brad Hartjes, of C.M. Lavoie has provided a corrected mark-up of the triple basin S29 (attached). Required modifications include removing the large steel plate south of the center concrete baffle, and adding an 18" clean-out hole with a 1/2" galvanized steel cover plate in the north concrete baffle the same as in the south baffle. Please proceed with these modifications and provide a cost estimate as soon as possible.
3. The last attached sketch shows a new location for catch basin S7 dimensioned off the existing building (former Hart's garage).

Please let me know if you have any questions.

*Sara Davis*

File  
Brad Hartjes



RECEIVED

JAN 09 2004

TURNER CONSTRUCTION CO.

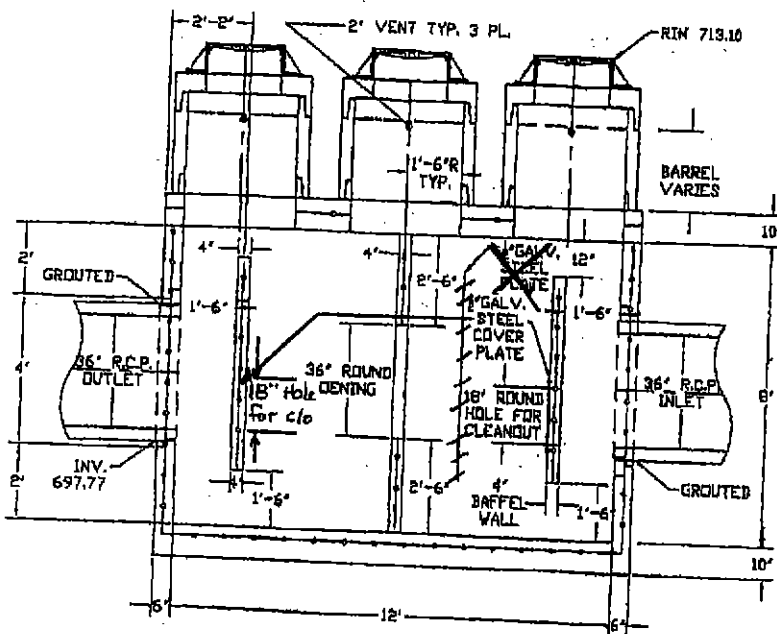
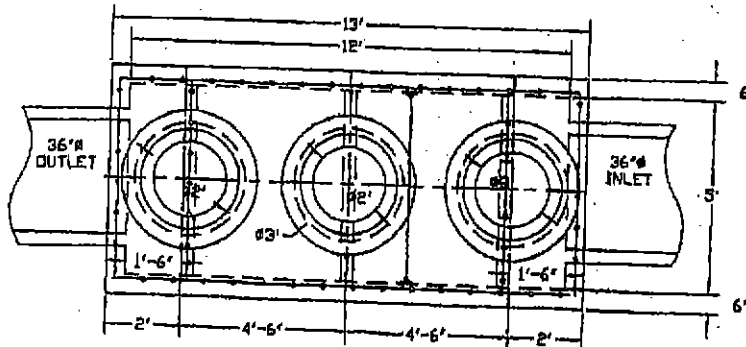

Job # 9202 Submittal # 215-2 Submission  
 Review of this shop drawing does not relieve the Engineer, or Subcontractor of their contractual responsibilities. Turner Construction Company is viewed and is not in any way responsible for elements, load or dimension calculations or similar. The Subcontractor is responsible to furnish material or work as required by the contract and this documents. The Subcontractor is responsible dimensions to be confirmed and correlated with  
**TURNER CONSTRUCTION COMPANY**  
 Reviewed By: [Signature]  
 Date: 1-9-04  
 Sample Description:

RECEIVED  
 MAR 29 2004  
 BY: 110

WALLS & BOTTOM TO HAVE #4 BAR @ 6' O.C. E.W.  
 TOP TO HAVE #5 BAR @ 6' O.C. E.W.

CONCRETE TO BE 5000 LBS PSI AFTER 28 DAYS

**WELCH BROS., INC.**

PRODUCERS OF QUALITY PRECAST CONCRETE PRODUCTS

ELGIN MAIN OFFICE  
 1050 St. Charles Street  
 Elgin, Illinois 60120  
 (847) 741-6134  
 FAX (847) 741-6195

CARY, IL  
 (847) 639-6134  
 FAX (847) 639-0532

BELVIDERE, IL  
 (815) 547-3000  
 FAX (815) 544-9481

Approved

Not Approved  
 Revise and Resubmit  
 As Noted

Reject

The engineer's review of these documents is only for the limited purpose of checking for general conformance with the design concept of the project, and conformance with the information provided in the contract documents.

Corrections or comments made during the engineer's review do not relieve the contractor from responsibility for any deviations or omissions from the requirements of the contract documents.

The contractor shall be responsible for confirmation of all quantities and dimensions, and for the correct fabrication, supply and installation of the work in compliance with the contract documents. The contractor is responsible for coordinating his work with that of all other trades and disciplines.

CONTRACTOR  
**DAWN COMPANIES**

JOB  
 PARKING FACILITY  
 **DOWNERS GROVE-IL**

APPROVED SUBMITTAL  
 **SPECIAL UTILITY BASIN**

DATE 01-09-2004 DRAWN BY **L.M.J.**  
 KEVIN