

## COUNCIL WORKSHOP ITEM

**ITEM:** Bid Recommendation, CBD Phase 4 Streetlight Purchase, Project #20-00  
**DATE:** January 2, 2001  
**PREPARED BY:** Jane Gerdes, Senior Engineer, Department of Public Works  
**PURPOSE:** Place award of contract on the January 16, 2001 Consent Agenda.

### DISCUSSION:

The goal of the CBD Phase 4 Streetlight Purchase project is to procure streetlight poles and fixtures to be used in the reconstruction of Washington Street, Main Street (north of the tracks) and Warren Avenue (Forest to Main) during 2001. The contract deadline for delivery of materials is June 1, 2001, to ensure that materials are on hand for installation in a timely manner.

The bid opening for Project 20-00, CBD Phase 4 Streetlight Purchase was held on Wednesday, December 13, 2000 at 10:00 a.m. Only one (1) bid was received. The bid was submitted by Thorne Electric, Inc., who was the low bidder from last year's (2000) contract. Thorne Electric, Inc. proposed the same unit price of \$1,850 per pole (for the 12-foot high pole and fixture) as they bid in last year's contract. Because Thorne Electric, Inc. held last year's unit price and because they performed well, staff recommends accepting their bid.

It should be noted that this contract is for the purchase of streetlight materials, only, delivered to the Village. Further costs will be incurred with this year's CBD construction for the construction of the streetlight foundations and streetlight installation and wiring.

### ATTACHMENT:

A copy of the bid document is attached.

### RECOMMENDATION:

Staff recommends that the contract for Project 20-00, CBD Phase 4 Streetlight Purchase, be awarded to Thorne Electric, Inc. in the amount of \$166,635.00 plus a 5% contingency of \$8,331.75. Thorne Electric, Inc. was the low bidder on last year's streetlight purchase contract and delivered material in a timely manner. Thorne Electric, Inc. has been the electric subcontractor to Martam Construction, Inc. for the 1998, 1999 and 2000 CBD construction and has performed satisfactorily. Funds for this project are available in account 107.529.0000.5711.

Submitted By:

Thorne Electric, Inc.  
Contractor

P.O. Box 321  
Street Address

Wheaton, IL                      60189  
City                                      State    Zip

630-668-4853  
Phone No.

630-668-4879  
Fax No.

**VILLAGE OF DOWNERS GROVE**  
**DEPARTMENT OF PUBLIC WORKS**

**SPECIFICATIONS AND CONTRACT**

**FOR**

**CBD Phase 4 Streetlight Purchase**

**PROJECT# 20-00**

**November, 2000**

## NOTICE TO CONTRACTORS

Sealed bids will be accepted by the Village of Downers Grove for:

### **CBD Phase 4 Streetlight Purchase**

until 10:00 a.m., December 13, 2000, at the Public Works Facility, 5101 Walnut Avenue, Downers Grove, Illinois 60515-4776, and, at that time, publicly opened and read.

This project consists of providing and delivering approximately eighty-seven (87) cast aluminum streetlight poles and providing and delivering approximately eighty-seven (87) new HPS luminaires.

Contract documents and project specifications may be obtained beginning November 17, 2000, at the Public Works Facility, 5101 Walnut, Downers Grove, for a cost of five dollars (\$5.00). A bid deposit, equal to 5% of the bid, in cash, certified or cashier's check, or bid bond will be required. A One Year Performance Bond and Materials and Labor Payment Bond in the full amount of the contract will be required of the successful bidder or bidders.

Bids must be submitted on the forms furnished and must conform to the specifications. Bidders are advised to carefully apprise themselves of the contract specifications, as the contract will be awarded on the basis of the specifications, including all conditions thereof. The Village reserves the right to reject or award all or any part of any bid or contract and waive technicalities as may be deemed by the Village Council to be in the best interests of the Village.

This contract will not be awarded to any contractor, or to any firm, corporation, partnership or association in which such contractor has an interest, who has been determined after a hearing before the Illinois Department of Labor to have disregarded his obligations under the Prevailing Wage Act and whose name has been published in the Illinois Register by the Department less than two years prior to the award.

Inquiries and sealed bids shall be directed to David Conley, Director of Engineering, at (630) 434-5460.

VILLAGE OF DOWNERS GROVE  
DEPARTMENT OF PUBLIC WORKS

Published in the Downers Grove Reporter, November 17, 2000.

## INSTRUCTIONS TO BIDDERS

### CBD Phase 4 Streetlight Purchase

#### IB-1 STANDARD SPECIFICATIONS

The Standard Specifications for Water and Sewer Main Construction in Illinois, 5th edition and the Standard Specifications for Road and Bridge Construction as adopted by the Illinois Department of Transportation, January 1, 1997, and the Village of Downers Grove Water Distribution Specifications shall govern the construction of the proposed improvement. In the event that there are conflicts in the wording or statements between the Standard Specifications for Water and Sewer Main Construction in Illinois or the Standard Specifications for Road and Bridge Construction and the Project Contract Document Specifications of the Village of Downers Grove, Illinois, the Contract Document Specifications shall take precedence. Contract Document Specifications include the Notice to Contractors, Instructions to Bidders, Supplementary Conditions, Special Provisions and Proposal.

#### IB-2 CONTENTS OF THE PROPOSAL FORM

Bidders will be furnished with forms stating the location and description of the Work contemplated, the approximate quantities of Work to be performed, the amount of the Proposal Guaranty, requirements pertaining to labor, and the date, time, and place of filing and opening Proposals. All documents bound with or attached to the Proposal shall be considered a part thereof, and shall not be detached or altered.

#### IB-3 INTERPRETATION OF ESTIMATE OF QUANTITIES

An estimate of quantities of Work to be done and materials to be furnished under the Specifications is given in the Proposal. It is given as a basis for comparison of Proposals and the Award of the Contract. The Owner does not expressly or by implication agree that the actual quantities involved will correspond therewith; nor shall the Bidder plead misunderstanding or deception because of such estimate of quantities, or of the character, location or other conditions pertaining to the Work.

Payment will be based on the actual quantities of Work performed in accordance with Contract, at the Contract unit prices specified. No allowance will be made for any change in anticipated profits due to an increase or decrease in the original estimate of quantities. The Owner reserves the right to omit any item entirely, or to increase or decrease any or all items.

#### **IB-4 EXAMINATION OF PLANS, SPECIFICATIONS, SPECIAL PROVISIONS, AND SITE OF WORK**

The bidder shall, before submitting his Bid, carefully examine the Proposal, Plans, Specifications, Special Provisions, and form of Contract and Bond. He shall inspect, in detail, the site of the proposed Work and familiarize himself with all the local conditions affecting the Contract, and the detailed requirements of construction. If his Bid is accepted, he will be responsible for all errors in his Proposal resulting from his failure or neglect to comply with these instructions. The Owner or Engineer will, in no case, be responsible for any change in anticipated profits resulting from such failure or neglect.

Should a bidder find, during the examination of the Contract Documents, or after his visit to the site, any discrepancies, omissions, ambiguities, or conflicts in or among the Contract Documents, or should he be in doubt as to their meaning, he shall at once bring the question to the attention of the Engineer for answer and interpretation. The Engineer will review the question and, where information sought is not clearly shown on the Contract Drawings or specified, he will issue an addendum to all bidders in which the interpretation will be made. The Engineer will make no interpretations orally and only instructions in writing will be deemed valid. Neither the Owner nor the Engineer will be responsible for any oral instructions. To receive consideration, requests for interpretation must be made not later than three (3) days prior to the date set for receipt of bids. All addenda to bidders are to be incorporated in the bids and will become a part of the Contract Documents.

When the Plans or Special Provisions include information pertaining to sub-surface exploration, borings, test pits, and other preliminary investigations, such information is included only for the convenience of the Bidder. The Owner or Engineer assumes no responsibility whatever in respect to the sufficiency of the information, and there is no guarantee, either expressed or implied, that the conditions indicated are representative of those existing throughout the Work, or that unanticipated developments may not occur.

When the Plans or Special Provisions include information pertaining to the location of underground utility facilities, such information is only included for the convenience of the Bidder. The Owner or Engineer assumes no responsibility whatever in respect to the sufficiency or accuracy of the information, or lack of information shown on the Plans relative to the location of underground utility facilities. It shall be the Contractor's responsibility to obtain from the respective utility companies detailed information relative to the location of their facilities and the work schedules of the utility companies for removing or adjusting them. Utilities whose facilities may be affected by the work include, but may not be limited to, the following: Nicor Gas, Commonwealth Edison Co., Ameritech, Media One and the Downers Grove Sanitary District. The Village of Downers Grove is not a member of JULIE. Information regarding Village water lines, storm sewers, and street lighting shall be obtained from the Village of Downers Grove Public Works Department.

## **IB-5 PREPARATION OF THE PROPOSAL**

The Bidder must submit his Proposal on the form furnished by the Owner. The Proposal shall be executed properly, and Bids shall be made for all items indicated in the Proposal form, except that when alternate Bids are asked, a Bid on more than one alternate for each item is not required, unless the Special Provisions provide otherwise. The Bidder shall indicate, in figures, a unit price or lump sum for each of the separate items called for in the Proposal; he shall show the products of the respective quantities and unit prices in the column provided for that purpose, and the gross sum shown in the place indicated in the proposal shall be the summation of said products. All unit prices shall be conditioned on furnishing a Bid Bond executed by a corporate surety company satisfactory to the Owner. All writing shall be with ink or typewriter, except the signature of the Bidder, which shall be written with ink.

If the Proposal is made by an individual, his name and post office address shall be shown. If made by a firm or partnership, the name and post office address of each member of the firm or partnership shall be shown. If made by a corporation, the proposal shall show the names, titles, and business addresses of the president, secretary, and treasurer, and the seal of the corporation shall be affixed and attested by the secretary.

## **IB-6 MULTIPLE BIDS**

If multiple bids are to be received, bidding shall be in accordance with the instructions in the Special Provisions.

## **IB-7 REJECTION OF PROPOSALS**

Proposals that contain omissions, erasures, alterations, additions not called for, conditional or alternate bids, unless called for, irregularities of any kind, or Proposals otherwise regular which are not accompanied by the proper Proposal Guaranty, shall be rejected as informal or insufficient. However, the Owner reserves the right to reject any or all Proposals and to waive such technical error as may be deemed best for the interest of the Owner.

## **IB-8 PROPOSAL GUARANTY**

Each Proposal shall be accompanied by a Bid Bond acceptable to the Owner, bank cashier's check or a properly certified check for not less than five (5) per cent of the amount of the Bid.

If a multiple Bid is submitted, the Bid Bond, bank cashier's check, or certified check which accompany the individual Proposal making up the combination be considered as also covering the multiple Bid.

The Bid Bonds, bank cashier's checks, or certified checks accompanying Proposals shall be made payable to the Owner.

#### **IB-9 DELIVERY OF PROPOSALS**

**Proposals will be accepted until 10:00 a.m., December 13, 2000, at the Public Works Facility, 5101 Walnut Avenue, Downers Grove, Illinois.** Proposals received after that time will be rejected and returned to the bidder unopened.

Proposals shall be submitted in an opaque sealed envelope marked with the Project Title and the name and address of the Bidder and accompanied by the Proposal Security and other required documents. If the Proposal bid is sent through the mail or other delivery system the sealed envelope shall be enclosed in a separate envelope with the notation "BID ENCLOSED" on the face thereof.

#### **IB-10 MODIFICATION AND WITHDRAWAL OF PROPOSALS**

Proposals may be withdrawn upon presentation of appropriate documentation, duly executed in the manner that the Proposal must be executed, to the Owner, at the place where Proposals are to be submitted at any time prior to the opening bids. Withdrawn Proposals may be re-submitted up to the time designated for the receipt of Proposals provided that they are then fully in conformance with these Instructions to Bidders.

#### **IB-11 PUBLIC OPENING OF PROPOSALS**

All Proposals received and accepted shall be opened and publicly read aloud at the Public Works Facility on December 13, 2000, as soon after the above stated time as is practical. Bidders, their authorized agents, and other interested parties are invited to be present.

#### **IB-12 DISQUALIFICATION OF BIDDERS**

Any one or more of the following causes may be considered as sufficient for the disqualification of a Bidder and the rejection of his Proposal:

- (a) More than one Proposal for the same Work from an individual, firm, partnership, or corporation under the same or different names.
  
- (b) Evidence of collusion among Bidders.

- (c) Unbalanced Proposals in which the prices for some items are substantially out of proportion to the prices for other items.
- (d) Failure to submit a unit price for each item of Work listed in the Proposal.
- (e) Lack of competency as revealed by financial statement or experience questionnaire, if such are required by the Special Provisions.
- (f) Unsatisfactory performance record as shown by past work, judged from the standpoint of workmanship and progress.
- (g) Incomplete work which, in the judgment of the Owner, might hinder or prevent the prompt completion of additional work.
- (h) Failure to submit a signed Contractors Certificate stating that the contractor is not barred from bidding this contract as a result of a violation of Section 33E-3 or 33E-4 of Chapter 38 of the Illinois Revised Statutes and that he is not delinquent in the payment of any tax administered by the Department of Revenue.

### **IB-13 COMPETENCY OF BIDDERS**

The Bidder, if a corporation, shall show the name of the State in which the corporation is chartered. Each Bidder shall furnish the Owner, upon request, with satisfactory evidence of his competency to perform the Work contemplated. When requested, he shall submit to the Engineer a financial statement prepared by a Certified Public Accountant showing his financial condition at the end of his past fiscal year. The accountant who prepares the statement shall certify that he holds a valid and unrevoked certificate as a Certified Public Accountant, issued in accordance with the laws of the State in which he is licensed. The Bidder, if requested, shall also answer and submit questionnaires relating to his experience and available equipment for performing construction work similar to that for which he is offering a Proposal.

Before an Award is made, the Bidder may, at the option of the Owner, be required to furnish a statement showing the value of all incomplete work for which he has entered into contracts.

#### **IB-14 CONSIDERATION OF PROPOSALS**

The Proposals received will be compared on the basis of the summation of the products of the items of Work listed and the unit prices offered. In case of discrepancy between the gross sum shown in the Proposal prices, the unit prices shall govern, and errors found in said products shall be corrected. In awarding Contracts, the Owner will, in addition to considering the amounts stated in the Proposals, take into consideration the responsibility of the various Bidders as determined from a study of the data required under the previous article and from other investigations which the Owner may elect to make.

#### **IB-15 AWARD OF CONTRACT**

Except in cases where the Owner exercises the right reserved to reject any or all Proposals, the Contract will be Awarded, as soon as practicable after the opening of Proposals.

Unless otherwise specified, if a Contract is not awarded within sixty (60) days after the opening of Proposals, a Bidder may file a written request with the Owner for the withdrawal of his Bid. The Owner will have a maximum of ten (10) days after the receipt of such request to Award the Contract or release the Bidder from further obligation by return of the Bidder's Proposal Guaranty.

#### **IB-16 RETURN OF PROPOSAL GUARANTY**

The Proposal Guaranties of all except the three lowest Bidders will be returned promptly after the Proposals have been checked. Proposal Guaranties of the three lowest Bidders will be returned as soon as the Contract and bond of the successful Bidder have been properly executed and approved.

If Contracts cannot be awarded promptly, the Owner shall permit the three (3) lowest Bidders to substitute a bid bond or other securities as approved by the Owner for the bank cashier's checks, or certified checks which they may have submitted with their Proposals as Proposal Guaranties, but such substitutions shall not be made until a period of three (3) days has elapsed after the date of opening Proposals.

#### **IB-17 REQUIREMENT OF CONTRACT BOND**

The successful Bidder, at the time of the execution of the Contract, shall deposit with the Owner a Performance Bond and a Materials and Labor Payment Bond acceptable to the Owner in the full amount of the Contract. Such bonds shall guarantee the Bidder's performance under the Contract and shall guarantee payment of all subcontractors and material suppliers.

## **IB-18 EXECUTION OF THE CONTRACT**

The Contract shall be executed by the Bidder. The Bonds, when required shall be executed by the principal and sureties, and executed Contract and Bonds shall be presented to the Owner within ten (10) days after the receipt of the Notice of Award, and the Contract.

## **IB-19 FAILURE TO EXECUTE CONTRACT**

Failure on the part of the successful bidder to execute a contract and provide acceptable bonds, as provided herein, within ten (10) days from the date of receipt of the contract and Notice of Award from the Owner, will be considered as just cause for the revocation of the award and the forfeiture of the Proposal Guaranty to the Owner, not as a penalty but in payment of liquidated damages sustained as a result of such failure.

The Bidder shall not be allowed to claim lack of receipt where the Contract and Notice of Award was mailed by U.S. Postal Services certified mail to the business address listed in his proposal. In case the Owner does not receive evidence of receipt within ten (10) days of the date of Notice of Award, the Owner may revoke the award and the Bidder shall forfeit the Proposal Guaranty to the Owner not as a penalty but in payment of liquidated damages sustained as the result of such failure.

## **IB-20 AFFIDAVIT**

Bidder shall complete and submit with his Proposal an "Affidavit" (Form BC-57) listing all incomplete contracts, including subcontract work; all pending low bids not yet awarded or rejected, and equipment available.

## SUPPLEMENTARY CONDITIONS

### CBD Streetlight Rehabilitation

#### GENERAL

The following Supplementary Conditions shall modify, delete, and/or add to the Division I General Requirements and Covenants of the Standard Specifications for Water and Sewer Main Construction in Illinois, 5th Edition and the Standard Specifications for Road and Bridge Construction as adopted by the State of Illinois Department of Transportation, January 1, 1997, except as amended herein. Where any section, subsection, paragraph, or subparagraph of Division I of the Standard Specifications for Water and Main Construction in Illinois, 5th Edition and/or the Standard Specifications for Road and Bridge Construction as adopted by the State of Illinois Department of Transportation, January 1, 1997, is supplemented by one of the following paragraphs, the provisions of such section, subsection, paragraph, or subparagraph shall remain in effect and the Supplementary Provisions shall be considered as added thereto. Where any section, subsection, paragraph, or subparagraph of Division I of the Standard Specifications for Water and Sewer Main Construction in Illinois, 5<sup>th</sup> Edition and/or the Standard Specifications for Road and Bridge Construction as adopted by the State of Illinois Department of Transportation, January 1, 1997, is amended, voided, or superseded by any of the following paragraphs, the provisions of such section, subsection, paragraph, or subparagraph not so amended, voided or superseded shall remain in effect.

The work described herein shall generally consist of the furnishing and delivering approximately eighty-seven (87) new cast aluminum streetlight poles, including banner brackets, flag pole holders, and duplex outlets with new HPS luminaires. This work shall also include delivery and unloading the new protective-wrapped poles and the packaged new luminaires at 801 Burlington, Downers Grove.

#### SC-1 PROPOSAL REQUIREMENTS AND CONDITIONS

Delete Section 2 in its entirety. It has been superseded by the Instructions to Bidders.

#### SC-2 AWARD AND EXECUTION OF CONTRACT

Delete Section 3 in its entirety. It has been superseded by the Instructions to Bidders.

#### SC-3 PRECONSTRUCTION CONFERENCE

Prior to commencing construction, a meeting will be held with the contractor, the Owner and its Agent, and a representative from the user department of the Village. Any questions concerning procedures, general conditions, special provisions, plans or specific items related to the project shall be answered and clarified.

No preconstruction meeting shall be scheduled until submittals, performance bonds, and certificates of insurance are delivered to, and approved by the contract administrator.

The Contractor shall be responsible for daily inspection of the work to ensure compliance with the published plans and specifications.

#### SC-4 BACKING PRECAUTIONS

The following section is to be added.

PROJECT #20-00

### 7-1.1 BACKING PRECAUTIONS

Pursuant to Sections 14-139(b) and 14-171.1 of the Downers Grove Municipal Code, any motor vehicle which has an obstructed view to the rear and is to be operated at any time in reverse gear on the public streets of the Village of Downers Grove by the Contractor or any subcontractor shall either be equipped with a reverse signal alarm (back up alarm) audible above and distinguishable from the surrounding noise level, or shall provide an observer to signal that it is safe to back up.

### **SC-5 BILLING & PAYMENT PROCEDURES**

Payment will be made upon receiving an invoice referencing **CBD Phase 4 Streetlight Purchase, PROJECT #20-00**. Once the invoice and receipt of materials or service have been verified, the invoice will be processed for payment in accordance with the Village of Downers Grove payment schedule. Please send all invoices to the attention of Jane Gerdes, Senior Engineer, Village of Downers Grove, Department of Public Works, 5101 Walnut Avenue, Downers Grove, Illinois 60515.

### **SC-6 OVERWEIGHT, OVERWIDTH AND OVERHEIGHT PERMITS**

The Village has and supports an overweight truck enforcement program. Contractors are required to comply with weight requirements and safety requirements as established by Illinois Law or Village Ordinance, for vehicles, vehicle operators, and specialty equipment. In some instances, specialty equipment for road repairs or construction projects requires the movement of overweight, overwidth or overheight loads utilizing a Village of Downers Grove roadway. Such movement will require obtaining a permit and permission as follows:

- A. The Police Department Traffic Supervisor will receive and issue all overweight, overwidth and overheight permits.
- B. The Police Department, upon receiving such a request, will determine and direct permit applicant which route will be authorized.
- C. The Police Department will retain one copy of completed permit form, and one copy will be forwarded to Village Operations Center.

### **SC-7 HOURS OF WORK**

The Contractor shall do no work between the hours of 7:00 p.m. and 7:00 a.m., nor on Saturdays, Sundays or legal holidays, except such work as necessary for the proper care and protection of work already performed, or except in case of an emergency and, in any case, only by the permission of the Engineer.

It is understood, however, that night work may be established as regular procedure by the Contractor if he first obtains the written permission of the Engineer, and that such permission may be revoked at any time by the Engineer if the Contractor fails to maintain night adequate force and equipment for reasonable prosecution and justification for inspection of the work.

### **SC-8 INDEMNITY AND HOLD HARMLESS AGREEMENT**

To the fullest extent permitted by law, the Awarded Contractor shall indemnify, keep and save harmless the Owners and their agents, officers, and employees, against all injuries, deaths, losses, damages, claims, suits, liabilities, judgments, costs and expenses, (including any liability under the Illinois Structural Work Act, known as the Scaffolding Act), which may arise directly or indirectly from any negligence or from the reckless

PROJECT #20-00

or willful misconduct of the Awarded Contractor, its employees, or its subcontractors, and the Awarded Contractor shall at its own expense, appear, defend and pay all charges of attorneys and all costs and other expenses arising therefrom or incurred in connection therewith, and, if any judgment shall be rendered against the Owner in any such action, the Awarded Contractor shall, at its own expense, satisfy and discharge the same. This Agreement shall not be construed as requiring the Awarded Contractor to indemnify the Owners for their own negligence. The Awarded Contractor shall indemnify, keep and save harmless the Owners only where a loss was caused by the acts or omissions of the Contractor, its employees, or its subcontractors.

#### **SC-9 NONDISCRIMINATION**

(a) Awarded Contractor shall, as a party to a public contract:

- (1) Refrain from unlawful discrimination in employment and undertake affirmative action to assure equality of employment opportunity and eliminate the effects of past discrimination;
- (2) By submission of this proposal, the Bidder certifies that he is an "equal opportunity employer" as defined by Section 2222(e) of Chapter 21, Title 42, U.S. Code Annotated and Executive Orders #11246 and #11375, which are incorporated herein by reference. The Equal Opportunity clause, Section 6.1 of the Rules and Regulations of the Department of Human Rights of the State of Illinois, is a material part of any contract awarded on the basis of this proposal.

(b) It is unlawful to discriminate on the basis of race, color, sex, national origin, ancestry, age, marital status, physical or mental handicap or unfavorable discharge for military service. Bidder shall comply with standards set forth in Title VII of the Civil Rights Act of 1964, 42 U.S.C. Secs. 2000 et seq., The Human Rights Act of the State of Illinois, 68 ILL. Rev. Stat. Secs. 1-101 et seq., and The Americans with Disabilities Act, 42 U.S.C. Secs. 12101 et seq.

#### **SC-10 INSURANCE REQUIREMENTS**

Section 7-2 is hereby deleted in its entirety and in its place is substituted the following:

##### **INSURANCE REQUIREMENTS FOR CONTRACTORS/SUPPLIERS**

Contractor shall procure and maintain for the duration of the contract, insurance against claims for injuries to persons or damages to property which may arise from or in connection with the performance of the work hereunder by the Contractor, his agents, representatives, employees or subcontractors. The cost of such insurance shall be included in the Contractor's bid.

##### **A MINIMUM SCOPE OF INSURANCE**

Coverage shall be at least as broad as:

1. Insurance Services Office form number GL 0002 (Ed. 1/73) covering Comprehensive General Liability and Insurance Services Office form number GL 0404 covering Broad Form Comprehensive General Liability; or Insurance Services Office Commercial General Liability coverage ("occurrence" form CG 0001).
2. Insurance Services Office form number CA0001 (Ed. 1/87) covering Automobile Liability Code 1 ("any auto").

PROJECT #20-00

3. Workers` Compensation insurance as required by the State of Illinois and Employer`s Liability Insurance.

**B. MINIMUM LIMITS OF INSURANCE**

Contractor shall maintain limits no less than:

1. General Liability: \$1,000,000 combined single limit per occurrence for bodily injury, personal injury and property damage.
2. Automobile Liability: \$1,000,000 combined single limit per accident for bodily injury and property damage.
3. Workers` Compensation and Employers` Liability: Workers` compensation limits as required by the Labor Code of the State of Illinois and Employers` Liability limits of \$500,000 per accident.

**C. DEDUCTIBLES AND SELF-INSURED RETENTIONS**

Any deductibles or self-insured retentions must be declared to and approved by the Agency. At the option of the Municipality, either: the insurer shall reduce or eliminate such deductibles or self-insured retentions as respects the Municipality, its officers, officials, employees and volunteers; or the Contractor shall procure a bond guaranteeing payment of losses and related investigations, claim administration and defense expenses.

**D. OTHER INSURANCE PROVISIONS:**

The policies are to contain, or be endorsed to contain, the following provisions:

1. General Liability and Automobile Liability Coverages.
  - a. The Municipality, its officers, officials, employees and volunteers are to be covered as insureds as respects: liability arising out of activities performed by or on behalf of the Contractor, premises owned, occupied or used by the Contractor, or automobiles owned, leased, hired or borrowed by the Contractor, and products and completed operations of the vendor. The coverage shall contain no special limitations on the scope of protection afforded to the Municipality, its officers, officials, employees or volunteers. The wording, "The Village of Downers Grove, its officers and employees are additional named insured", must appear on the certificate.
  - b. The Contractor/Vendor`s insurance coverage shall be primary insurance as respects the Municipality, its officers, officials, employees, and volunteers. Any insurance or self-insurance maintained by the Municipality, its officers, officials, employees or volunteers shall be excess of the Contractor`s insurance and shall not contribute with it.
  - c. Any failure to comply with reporting provisions of the policies shall not affect coverage provided to the Municipality, its officers, officials, employees or volunteers.
  - d. The Contractor/Vendors insurance shall apply separately to each insured against whom claim is made or suit is brought except with respect to the limits of the

PROJECT #20-00

insurer's liability.

2. Workers` Compensation and Employers Liability Coverage

The insurer shall agree to waive all rights of subrogation against the Municipality, its officers, officials, employees and volunteers for losses arising from work performed by the Contractor for the Municipality.

3. All Coverages

Each insurance policy required by this clause shall be endorsed to state that coverage shall not be suspended, voided, canceled by either party, reduced in coverage or in limits except after thirty (30) days` prior written notice by certified mail, return receipt requested, has been given to the Municipality.

**E. ACCEPTABILITY OF INSURERS**

Insurance is to be placed with insurers with a Best`s rating of no less than A:VII. Insurer shall be a licensed insurer in the State of Illinois.

**F. VERIFICATION OF COVERAGE**

Contractor shall furnish the Municipality with certificates of insurance and with original endorsements effecting coverage required by this clause. The certificates and endorsements for each insurance policy are to be signed by a person authorized by that insurer to bind coverage on its behalf. The certificates are to be received and approved by the Municipality before work commences. The Municipality reserves the right to require complete, certified copies of all required insurance policies, at any time.

**G. SUBCONTRACTORS**

Contractor shall include all subcontractors as insureds under its policies or shall furnish separate certificates and endorsements for each subcontractor. All coverages for subcontractors shall be subject to all of the requirements stated herein.

Are you willing to comply with the Village's preceding insurance requirements within 13 days of the award of the contract? Yes

INSURER'S NAME Heritage Insurance Co.

AGENT Langan Haeger Vincent & Born, Inc.

Street Address 211 E. Illinois St.

City, State, Zip Code Wheaton, IL 60187

Telephone Number 630-668-6644

Fill Out Applicable Paragraph Below)

(a) **Corporation**

The Supplier is a corporation organized and existing under the laws of the State of Illinois, which operates under the Legal name of Thorne Electric, Inc., and the full names of its Officers are as follows:

President: Marion P. Thorne

Secretary: Lolita Thorne

Treasurer: Cynthia D. Thorne

and it does have a corporate seal. (In the event that this bid is executed by other than the President, attach hereto a certified copy of that section of Corporate by-laws or other authorization by the Corporation which permits the person to execute the offer for the corporation.)

(b) **Partnership**

Signatures and Addresses of All Members of Partnership:

\_\_\_\_\_  
\_\_\_\_\_  
\_\_\_\_\_  
\_\_\_\_\_

The partnership does business under the legal name of:

\_\_\_\_\_ which name is registered with the  
office of \_\_\_\_\_ in the state of  
\_\_\_\_\_

(c) **Sole Proprietor**

The Supplier is a Sole Proprietor whose full name is \_\_\_\_\_

\_\_\_\_\_

and if operating under a trade name, said trade name is \_\_\_\_\_

\_\_\_\_\_ which name is  
registered with the office of \_\_\_\_\_

in the state of \_\_\_\_\_

EXAMPLE OF REQUIRED CERTIFICATE OF INSURANCE FOR CONTRACT WORK FOR THE  
VILLAGE OF DOWNERS GROVE.

PROJECT: CBD Phase 4 Streetlight Purchase, Project #20-00

<u>GENERAL LIABILITY</u>	<u>LIMITS OF LIABILITY IN THOUSANDS (000)</u>	
( X ) COMMERCIAL GENERAL LIABILITY	GENERAL AGGREGATE	\$1,000
	PRODUCTS COMP/OPS AGGREGATE	\$1,000
	PERSONAL & ADVERTISING INJURY	\$1,000
( X ) OCCURRENCE	EACH OCCURRENCE	\$1,000
	FIRE DAMAGE (ANY FIRE)	\$ 50
	MEDICAL EXPENSE (ANY ONE PERSON)	\$ 5
( X ) OWNER'S & CONTRACTORS PROTECTIVE		
 <u>AUTOMOBILE LIABILITY</u>		
( ) ANY AUTO	COMBINED SINGLE LIMIT	\$1,000
( X ) ALL OWNED AUTOS	BODILY INJURY (PER PERSON)	\$ 500
( ) SCHEDULED AUTOS	BODILY INJURY	\$1,000
( X ) HIRED AUTOS	(PER ACCIDENT)	
( X ) NON-OWNED AUTOS	PROPERTY DAMAGE (PER ACCIDENT)	\$ 250
( ) GARAGE LIABILITY		
 <u>EXCESS LIABILITY</u>		
( )	EACH OCCURRENCE	\$
( ) OTHER THAN UMBRELLA FORM	AGGREGATE	\$
 <u>WORKERS' COMPENSATION AND EMPLOYERS' LIABILITY</u>		
STATUTORY	EACH ACCIDENT	\$ 100
	DISEASE - POLICY LIMIT	\$ 500
	DISEASE - EACH EMPLOYEE	\$ 100

OTHER  
DESCRIPTION OF OPERATIONS/LOCATIONS/VEHICLES/RESTRICTIONS/SPECIAL ITEMS

THE VILLAGE OF DOWNERS GROVE, INCLUDING THEIR OFFICERS, EMPLOYEES AND AGENTS ARE NAMED ADDITIONAL INSURED FOR: CBD Ph. 4 Streetlight Purchase, Project 20-00.

PROJECT #20-00

## SC-11 EQUAL EMPLOYMENT OPPORTUNITY

In the event of the contractor's non-compliance with the provisions of this Equal Employment Opportunity Clause, the Illinois Human Rights Act, or the Rules and Regulations of the Illinois Department of Human Rights ("Department"), the contractor may be declared ineligible for future contracts or subcontracts with the State of Illinois or any of its political subdivisions or municipal corporations, and the contract may be cancelled or voided in whole or in part, and such other sanctions or penalties may be imposed or remedies invoked as provided by statute or regulation. During the performance of this contract, the contractor agrees as follows:

1. That it will not discriminate against any employee or applicant for employment because of race, color, religion, sex, marital status, national origin or ancestry, age, physical or mental handicap unrelated to ability, or an unfavorable discharge from military service; and further that it will examine all job classifications to determine if minority persons or women are underutilized and will take appropriate affirmative action to rectify any such underutilization.

2. That, if it hires additional employees in order to perform this contract or any portion thereof, it will determine the availability (in accordance with the Department's Rules and Regulations) of minorities and women in the area(s) from which it may reasonably recruit and it will hire for each job classification for which employees are hired in such a way that minorities and women are not underutilized.

3. That, in all solicitations or advertisements for employees placed by it or on its behalf, it will state that all applicants will be afforded equal opportunity without discrimination because of race, color, religion, sex, marital status, national origin or ancestry, age, physical or mental handicap unrelated to ability, or an unfavorable discharge from military service.

4. That it will send to each labor organization or representative of workers with which it has or is bound by a collective bargaining or other agreement or understanding, a notice advising such labor organization or representative of the contractor's obligations under the Illinois Human Rights Act and the Department's Rules and Regulations. If any such labor organization or representative fails or refuses to cooperate with the contractor in its efforts to comply with such Act and Rules and Regulations, the contractor will promptly so notify the Department and the contracting agency and will recruit employees from other sources when necessary to fulfill its obligations thereunder.

5. That it will submit reports as required by the Department's Rules and Regulations, furnish all relevant information as may from time to time be requested by the Department or the contracting agency, and in all respects comply with the Illinois Human Rights Act and the Department's Rules and Regulations.

6. That it will permit access to all relevant books, records, accounts and work sites by personnel of the contracting agency and the Department for purposes of investigation to ascertain compliance with the Illinois Human Rights Act and the Department's Rules and Regulations.

7. That it will include verbatim or by reference the provisions of this clause in every subcontract it awards under which any portion of the contract obligations are undertaken or assumed, so that such provisions will be binding upon such subcontractor. In the same manner as with other provisions of this contract, the contractor will be liable for compliance with applicable provisions of this clause by such subcontractors; and further it will promptly notify the contracting agency and the Department in the event any subcontractor fails or refuses to comply therewith. In addition, the contractor will not utilize any subcontractor declared by the Illinois Human Rights Commission to be ineligible for contracts or subcontracts with the State of Illinois or any

PROJECT #20-00

of its political subdivisions or municipal corporations.

(Filed February 6, 1981, Effective February 9, 1981.)

#### **SC-12 BARRICADES AND WARNING SIGNS**

Section 7-8 is hereby amended by adding the following after the second paragraph:

The Contractor shall furnish the Owner a telephone number of a person or company which is available 24 hours a day to erect additional barricades or signs, which the Owner or his representative deem necessary for the Public's safety. If, after requesting the Contractor to furnish the necessary barricades or signs during normal working hours, or if after requesting the barricade company or individual to furnish the necessary barricades or signs after normal business hours, the requested signs are not in place within three hours, the Owner reserves the right to have the required barricades and signs erected, and deduct the expenses of such action from any payments due the Contractor.

#### **SC-13 HIRING PREFERENCE**

All persons hired by a Contractor or subcontractor for work done pursuant to this contract shall be hired in compliance with An Act to give preference in the construction of public works projects and improvements to citizens of the United States who have resided in Illinois for one year, filed July 29, 1929, as amended, provided that contracts involving the expenditure of federal aid funds shall not be required to comply with said statutes where its provisions conflict with federal statutes, rules and regulations.

#### **SC-14 COOPERATION OF CONTRACTOR**

The Contractor will be supplied with a minimum of 2 sets of approved plans and contract assemblies including Special Provisions, one set of which the Contractor shall keep available on the work site at all times.

The Contractor shall give the work site constant attention necessary to facilitate the progress thereof, and shall cooperate with the Owner or its Agent, in every way possible.

The Contractor shall have on the work site at all times, as the Contractor's Agent, a competent English-speaking Superintendent capable of reading and thoroughly understanding the Plans and Specifications, and thoroughly experienced in the type of work being performed, who shall receive instruction from the Owner or its Agent. The Superintendent shall have full authority to promptly supply such materials, equipment, tools, labor and incidentals as may be required. Such Superintendent shall be furnished irrespective of the amount of work sublet.

#### **SC-15 PROSECUTION OF THE WORK**

Section 8-4 is hereby amended by adding the following:

The Contractor shall not be allowed to claim lack of receipt where the Notice to Proceed was mailed by U.S. Postal Service certified mail to the business address listed in his Proposal. In the case where the Owner does not receive evidence of receipt within ten (10) days of the date of Notice to Proceed, the Owner may revoke the contract and find the Contractor in default.

PROJECT #20-00

#### **SC-16 FAILURE TO COMPLETE THE WORK ON TIME**

Section 8-11 is hereby deleted in its entirety and in its place is substituted the following.

Should the Contractor fail to complete the work within the contract time, the Contractor shall be liable to the Owner for liquidated damages as described in the Proposal, for each calendar day of overrun in the contract time.

#### **SC-17 SWORN STATEMENT AND WAIVERS OF LIEN**

The Owner requires that partial and final affidavits for all labor, materials and equipment used on the project, from all suppliers, be submitted with the part and final payment requests indicating that all labor, materials and equipment used on the project have been paid. A sworn statement by the contractor shall accompany full waivers. Such requirements of full waivers are solely for the benefit of the Owner and shall not be construed to benefit any other person. Partial payment for work done shall in no way imply acceptance of the work to that date.

#### **SC-18 FINAL INSPECTION**

Section 5-12 is hereby deleted in its entirety and in its place is substituted the following:

##### **5-12.1 FINAL ACCEPTANCE**

The Contractor shall notify the Owner that the project is completed and ready for initial inspection. If any part of the work is not acceptable to the Owner at the time of such inspection, the Owner shall inform the Contractor in writing of any corrective work required.

The initial inspection shall include the inspection of all work done under the contract; removal of all surplus materials and debris; repair or replacement of any private or public property damaged, moved, or otherwise displaced on the site due to the construction of the project; the removal of all construction equipment and materials; and the complete restoration of all landscaping damaged during construction.

Final Acceptance of the project will not be made until all defective work is remedied or removed and replaced. Upon satisfactory completion of any corrective work, the Owner will recommend "final acceptance" and a final pay estimate, less any previous payments, will be submitted to the Owner for his approval and payment. The quantities and amounts due the Contractor will be final and no adjustment in quantities and amounts due the Contractor will be allowed after approval of the final pay estimated by the Owner.

#### **SC-19 INTEREST ON MONEY DUE THE CONTRACTOR**

Section 9-8 is hereby deleted in its entirety.

#### **SC-20 ARBITRATION**

Section 9-11 is hereby deleted in its entirety.

PROJECT #20-00

#### **SC-21 SEXUAL HARRASSMENT POLICY**

The bidder or supplier shall, as a party to a public contract, have a written sexual harassment policy that:

1. Notes the illegality of sexual harassment;
2. Sets forth the State law definition of sexual harassment;
3. Describes sexual harassment utilizing examples;
4. Describes the bidder's or supplier's internal complaint process including penalties;
5. Describes the legal recourse, investigative and complaint process available through the Illinois Department of Human Rights and the Human Rights Commission and how to contact these entities, and;
6. Describes the protection against retaliation afforded under the Illinois Human Rights Act.

#### **SC-22 TAX EXEMPTION**

The Owner is exempt from the Illinois State and/or municipal or county retailers occupational tax, service occupation tax, use tax and service use tax, and Bid prices shall not include the cost of such taxes. Federal excise tax does not apply to materials or services purchased by Owner. Should the federal excise tax be applicable to this transaction, Owner will furnish a federal exemption certificate. The bid prices quoted herein by Bidder shall be deemed conclusively to include all other direct or indirect federal, state and local taxes which apply.

#### **SC-23 PREVAILING WAGE RATE**

This contract may be subject to AN ACT regulating wages of laborers, mechanics and other workers employed in any political subdivision or by anyone under contract for public works, approved June 26, 1941, as amended, except that where a prevailing wage violates a Federal law, order, or ruling, the rate conforming to the Federal law, order, or ruling shall govern.

If it is determined that the "prevailing rate of wages" will be used for this contract, the following conditions will be required.

Not less than the prevailing rate of wages as found by the (public body) or Department of Labor or determined by a court on review shall be paid to all laborers, workers and mechanics performing work under this contract.

The contractor and each subcontractor shall keep an accurate record showing the names and occupations of all laborers, workers and mechanics employed by them on this contract, and also showing the actual hourly wages paid to each of such persons.

The submission by the contractor and each subcontractor of payrolls, or copies thereof, is not required. However, the contractor and each subcontractor shall preserve their weekly payroll records for a period of three years from the date of completion of this contract.

PROJECT #20-00

PROJECT #20-00

SC-13

**SPECIAL PROVISIONS  
CBD PHASE 4 STREETLIGHT PURCHASE**

The Standard Specifications for Road and Bridge Construction as adopted by the Illinois Department of Transportation, January 1, 1997 shall govern the construction of the proposed improvement. References to AWWA/ANSI Standards shall be the latest revisions published as of the date of this contract.

The following Special Provisions supplement these Standard Specifications and in case of conflict, the Special Provisions shall take precedence and shall govern.

**SP-1 LUMINAIRE AND 12' STREETLIGHT POLE WITH BANNER BRACKETS  
LUMINAIRE AND 12' STREETLIGHT POLE WITH FLAG POLE HOLDER  
LUMINAIRE AND 12' STREETLIGHT POLE WITH FLAG POLE HOLDER AND  
60 AMP OUTLET**

Intent and Description of Work. The intent of this special provision is to provide a new 100 watt, high pressure sodium luminaire and a new cast aluminum 12' decorative streetlight pole to closely match the existing Antique Street Lamps, Inc. "Mariner" series streetlight poles and AT23 series single luminaires in place on Main Street between Maple Avenue and Burlington Avenue in the Village of Downers Grove, DuPage County, Illinois. (See attached catalog cuts and drawings.) This work shall be in accordance with applicable portions of Section 801, 830 and 844 of the Standard Specifications and this Special Provision.

Luminaire Requirements. The luminaires shall include a 15" diameter, 34.5" tall clear, textured polycarbonate acorn globe, a high intensity discharge ballast and socket assembly for a mogul base, a 100 watt high pressure sodium, 120 volt lamp with a borosilicate glass refractor with an IES Type III distribution, and a cast aluminum decorative luminaire base with a black powder coat finish, such as the LAT23 Luminaire, as manufactured by Antique Street Lamps, Inc., Austin Texas or approved equal.

***If an "approved equal" is bid, the bidder must submit complete catalog cuts or drawings with the bid.***

Pole Requirements. The poles shall be 12' cast aluminum, one-piece construction with a classical tapered base design, a 5" diameter fluted shaft and a black powder coat finish such as the Mariner series pole, as manufactured by Antique Street Lamps, Inc., Austin Texas or approved equal. Handhole cover plates shall be attached with countersunk (Allen wrench) 1" screws.

***If an "approved equal" is bid, the bidder must submit complete catalog cuts or drawings with the bid.***

The poles must include a 110-volt duplex receptacle with WPC-style, weatherproof (while-in-use) black cover attached to each pole, as shown in the drawings. The outlet shall be grounded to the ground rod in the concrete foundation (by others). In addition the following black finished appurtenances shall be provided:

Streetlight Pole with Banner Arms: two (2) eighteen inch (18") banner arms with removable finials and pole-attached receptacles, and one (1) twelve inch (12") ladder rest with finial and pole-attached receptacle, as shown on the drawing included herein.

Streetlight Pole Flag Pole Holder: two (2) twelve inch (12") ladder rests with finials and pole-attached receptacles, and one (1) flag pole holder with pole-attached receptacle, as shown on the drawing included herein.

Streetlight Pole Flag Pole Holder and 60 Amp Outlet: two (2) twelve inch (12") ladder rests with finials and pole-attached receptacles, one (1) flag pole holder with pole-attached receptacle, and one (1) 60 ampere twist lock type outlet Hubbell Model #26410 (or approved equal) attached to each pole, as shown on the drawing included herein.

Packaging, Transporting and Unloading. The luminaires, poles and appurtenances shall be protectively packaged to not incur damage during transportation or unloading. The materials shall be delivered and unloaded at a pre-arranged time and date at Village Hall, 801 Burlington, Downers Grove, IL. . The contractor shall provide all labor and equipment to unload the materials and stack them neatly in the Village's storage area. At the time of delivery, the protective packaging shall be removed at the direction of the Engineer to show condition of the material.

Basis of Payment: This work will be paid for at the contract unit price per each for **LUMINAIRE AND 12' STREETLIGHT POLE WITH BANNER BRACKETS, LUMINAIRE AND 12' STREETLIGHT POLE WITH FLAG POLE HOLDER, or, LUMINAIRE AND 12' STREETLIGHT POLE WITH FLAG POLE HOLDER AND 60 AMP OUTLET**, which price shall be payment in full for all work described herein.

## **SP-2 LUMINAIRE AND 29' STREETLIGHT POLE WITH MAST ARM AND DECORATIVE SHIRT**

Intent and Description of Work. The intent of this special provision is to provide a new 150 watt, high pressure sodium luminaire and a new steel 29' decorative streetlight pole with an 8' mast arm and decorative skirt to closely match the existing Valmont FL210 streetlight poles and luminaires in place at the intersections of Forest and Curtiss and at Forest and Gilbert in the Village of Downers Grove, DuPage County, Illinois. (See attached catalog cuts and drawings.) This work shall be in accordance with applicable portions of Section 801, 830 and 844 of the Standard Specifications and this Special Provision.

Luminaire Requirements. The luminaires shall include a high intensity discharge ballast and socket assembly for a mogul base, a 150 watt high pressure sodium, 120 volt lamp with an IES Type III distribution refractor, and a housing with a suitable polyester powder black finish matching the pole and mast arm, as shown on the drawing included herein.

Pole Requirements. The poles shall be 29' steel with a fluted tapered shaft, 8' mast arm and decorative skirt such as the Valmont FL210 pole, or approved equal. Pole, arm and skirt shall have a polyester powder black, as shown on the drawing included herein. Handhole cover plates shall be attached with countersunk (Allen wrench) 1" screws.

***If an "approved equal" is bid, the bidder must submit complete catalog cuts or drawings with the bid.***

Packaging, Transporting and Unloading. The luminaires, poles, arms, skirts and appurtenances shall be protectively packaged to not incur damage during transportation or unloading. The materials shall be delivered and unloaded at a pre-arranged time and date at Village Hall, 801 Burlington, Downers Grove, IL. The contractor shall provide all labor and equipment to unload the materials and stack them neatly in the Village's storage area. At the time of delivery, the protective packaging shall be removed at the direction of the Engineer to show condition of the material.

Basis of Payment: This work will be paid for at the contract unit price per each for **LUMINAIRE AND 29' STREETLIGHT POLE WITH MAST ARM AND DECORATIVE SKIRT**, which price shall be payment in full for all work described herein.

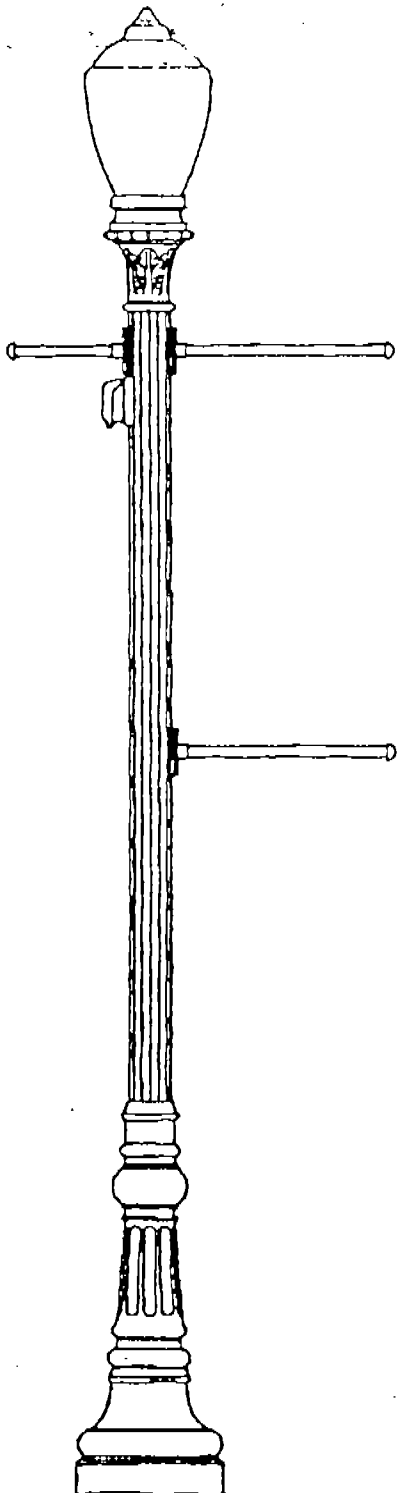

Banner Arms and Receptacle rotated 45° for illustration purposes, (See Orientation Drawing for location).

**Mariner Series  
Cast Aluminum Post**

**Post:**

Post shall be all aluminum construction, consisting of a classic, tapered and fluted cast base, a 5"Ø fluted shaft with a tenon for luminaire mounting. A door is located in the base for anchorage and wiring access.

**Luminaire:**

Luminaire shall be 15"Ø x 34 1/2" tall with clear, textured polycarbonate acorn globe and cast aluminum luminaire base.

Luminaire shall be furnished with a high intensity discharge ballast and socket assembly, and a borosilicate glass refractor with an IES Type III distribution.

Lamp Type	Mercury Vapor	Metal Halide	High Pressure Sodium	Voltage
HID Socket Size	<input type="checkbox"/> -H50	<input type="checkbox"/> -M50	<input type="checkbox"/> -S35	<input checked="" type="checkbox"/> 120
	<input type="checkbox"/> -H75	<input type="checkbox"/> -M70	<input type="checkbox"/> -S50	<input type="checkbox"/> 208
<input type="checkbox"/> -MED	<input type="checkbox"/> -H100	<input type="checkbox"/> -M100	<input type="checkbox"/> -S70	<input type="checkbox"/> 240
	<input type="checkbox"/> -H175	<input type="checkbox"/> -M150	<input checked="" type="checkbox"/> -S100	<input type="checkbox"/> 277
<input checked="" type="checkbox"/> -MOG	<input type="checkbox"/> -H250	<input type="checkbox"/> -M175	<input type="checkbox"/> -S150	<input type="checkbox"/> 480
		<input type="checkbox"/> -M250	<input type="checkbox"/> -S250	<input checked="" type="checkbox"/> QV

**Options & Accessories:** 18"

- 2BA24H1/BO - (2) bolt-on, 1" x 24" aluminum banner arms, with half-sphere finial.  
(See Orientation Drawing for location).
- BA12H1/BO - bolt-on, 1" x 12" aluminum banner arm, with half-sphere finial.  
(See Orientation Drawing for location).
- RS/GF/W/PS - duplex GFCI receptacle with small white-in-use weatherproof cover.  
(See Orientation Drawing for location).

**Anchorage:**

Post shall be furnished with (4) 3/4" x 24" x 3" hot-dip galvanized L-type anchor bolts, to be installed with a 2" projection each.

**Finish:**

Post, arms and luminaire shall be furnished with a black powder coat finish.

**Anchorage Detail**

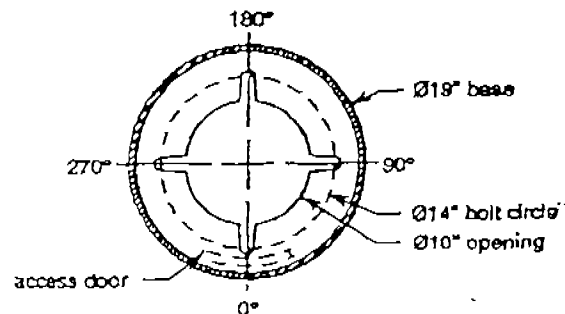

**Note:**

All hardware shall be stainless steel. All easily accessible exterior hardware shall be tamper resistant.

Post Height: 12'-0"      Overall Height: 14'-10 1/2"  
Base Diameter: 19"Ø      Light Center Height: 13'-9 1/2"

date: 06-07-99      scale: none      des. no.: L-4170E

**ANTIQU** Street Lamps, Inc.  
P.O. Box 150279 • Austin, TX 78715-0279  
(512) 295-3885 • Fax (512) 295-3330

SHOP DRAWING FOR ANTIQUE STREET LAMPS, INC. UNIT WITH BANNER ARMS  
(INSTALLED ON MAIN STREET IN DOWNERS GROVE) PAGE 1 OF 2

# Orientation Drawing

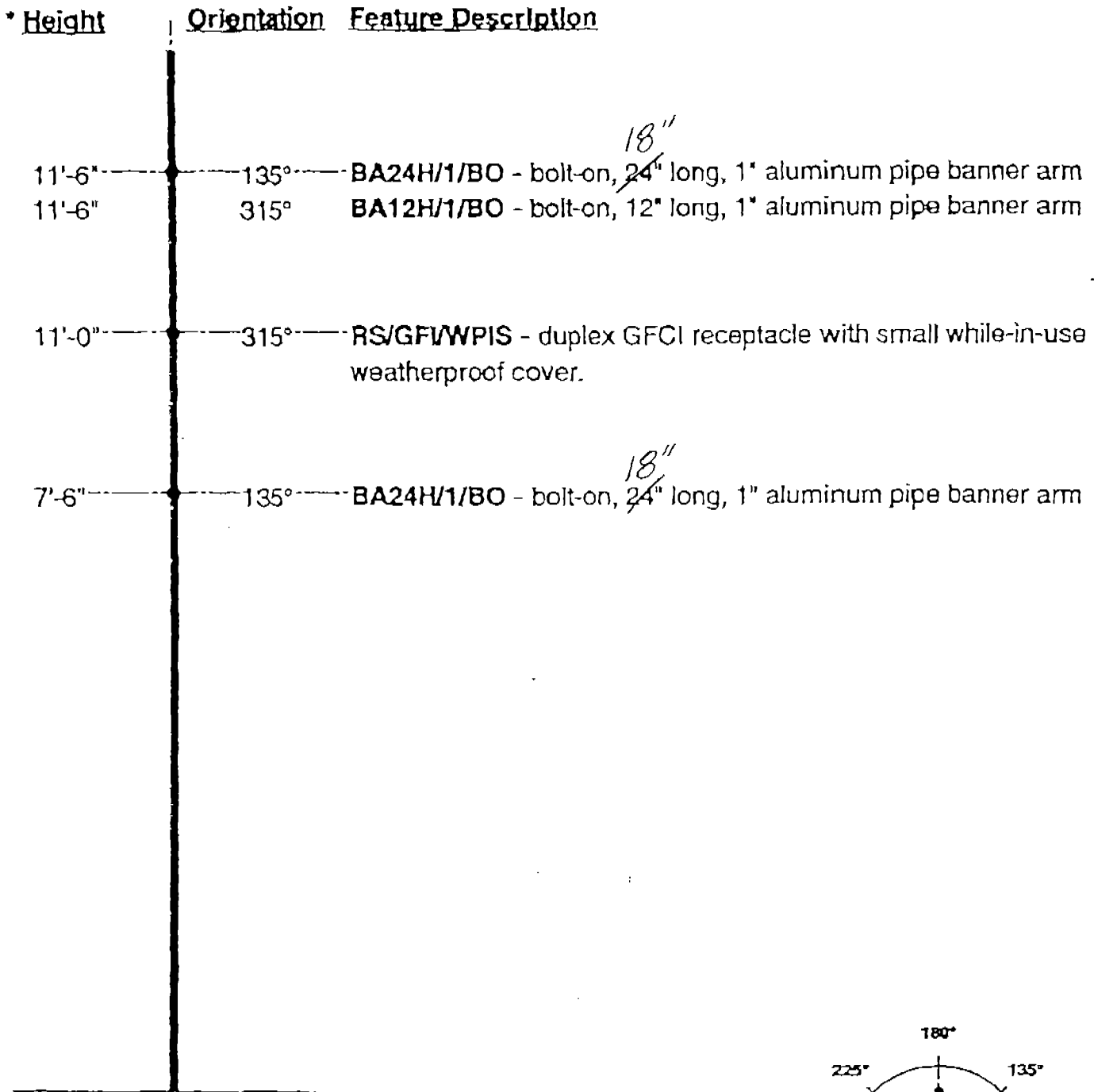

Post	Height
MR12F5/19-CA	12'-0"

\* Height from bottom of base / anchor plate.

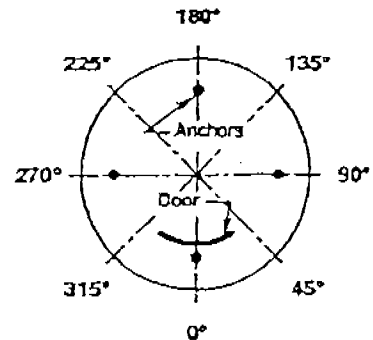

Orientation  
(top view)

SHOP DRAWING FOR ANTIQUE STREET LAMPS, INC. UNIT WITH BANNER ARMS  
(INSTALLED ON MAIN STREET IN DOWNERS GROVE) PAGE 2 OF 2

sign & date	<u><b>Customer Approval</b></u>
print	_____

date: 06-07-99	dwg. no.: OD-4170E
<b>ANTIQU</b> Street Lamps, Inc.	
P.O. Box 150279	• Austin, TX 78715-0279
(512) 295-3585	• Fax (512) 295-3330

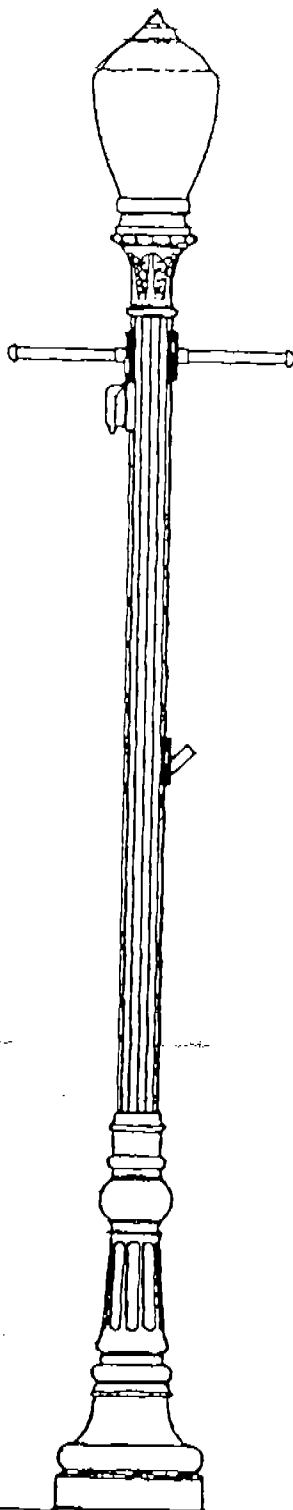

Inner Arms, Flag Pole Holder and Receptacle rotated 45° for orientation purposes, (See Orientation Drawing for location).

MR12F5/19-CA/BK-BC(0.75x14.0)-RS/GFWWPIS  
 -2BA12H/1/BO-CA/BK-FPH1/BO-CA/BK  
 LAT23/BK-S100/QV(120)-III

**Manner Series  
 Cast Aluminum Post**

**Post:**

Post shall be all aluminum construction, consisting of a classic, tapered and fluted cast base, a 5"Ø fluted shaft with a tenon for luminaire mounting. A door is located in the base for anchorage and wiring access.

**Luminaire:**

Luminaire shall be 15"Ø x 34 1/2" tall with clear, textured polycarbonate acorn globe and cast aluminum luminaire base.

Luminaire shall be furnished with a high intensity discharge ballast and socket assembly, and a borosilicate glass refractor with an IES Type III distribution.

Lamp Type	Mercury Vapor	Metal Halide	High Pressure Sodium	Voltage
HID Socket Size	<input type="checkbox"/> -H50	<input type="checkbox"/> -M50	<input type="checkbox"/> -S35	<input checked="" type="checkbox"/> 120
	<input type="checkbox"/> -H75	<input type="checkbox"/> -M70	<input type="checkbox"/> -S50	<input type="checkbox"/> 208
<input type="checkbox"/> -MED	<input type="checkbox"/> -H100	<input type="checkbox"/> -M100	<input type="checkbox"/> -S70	<input type="checkbox"/> 240
	<input type="checkbox"/> -H175	<input type="checkbox"/> -M150	<input checked="" type="checkbox"/> -S100	<input type="checkbox"/> 277
<input checked="" type="checkbox"/> -MOG	<input type="checkbox"/> -H250	<input type="checkbox"/> -M250	<input type="checkbox"/> -S150	<input type="checkbox"/> 480
			<input type="checkbox"/> -S250	<input checked="" type="checkbox"/> QV

**Options & Accessories:**

- 2BA12H/1/BO - (2) bolt-on, 1" x 12" aluminum banner arms, with half-sphere finial. (See Orientation Drawing for location).
- FPH1/BO - bolt-on, aluminum 1" flag pole holder, (Flag Pole Holder by others). (See Orientation Drawing for location).
- RS/GFWWPIS - duplex GFCI receptacle with small while-in-use weatherproof cover. (See Orientation Drawing for location).

**Anchorage:**

Post shall be furnished with (4) 3/4" x 24" x 3" hot-dip galvanized L-type anchor bolts, to be installed with a 2" projection each.

**Finish:**

Post, arms and luminaire shall be furnished with a black powder coat finish.

**Anchorage Detail**

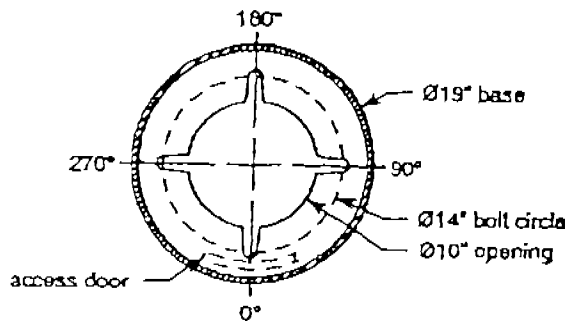

**Note:**

All hardware shall be stainless steel. All easily accessible exterior hardware shall be tamper resistant.

Post Height: 12'-0" Overall Height: 14'-10 1/2"  
 Base Diameter: 19"Ø Light Center Height: 13'-9 1/2"

date: 06-07-99 scale: none dwg. no.: L-4170G

**ANTIQUE Street Lamps, Inc.**

P.O. Box 150279 • Austin, TX 78715-0279  
 (512) 295-3885 • Fax (512) 296-3330

SHOP DRAWING FOR ANTIQUE STREET LAMPS, INC. UNIT WITH FLAG POLE HOLDER  
 (INSTALLED ON MAIN STREET IN DOWNERS GROVE) PAGE 1 OF 2

# Orientation Drawing

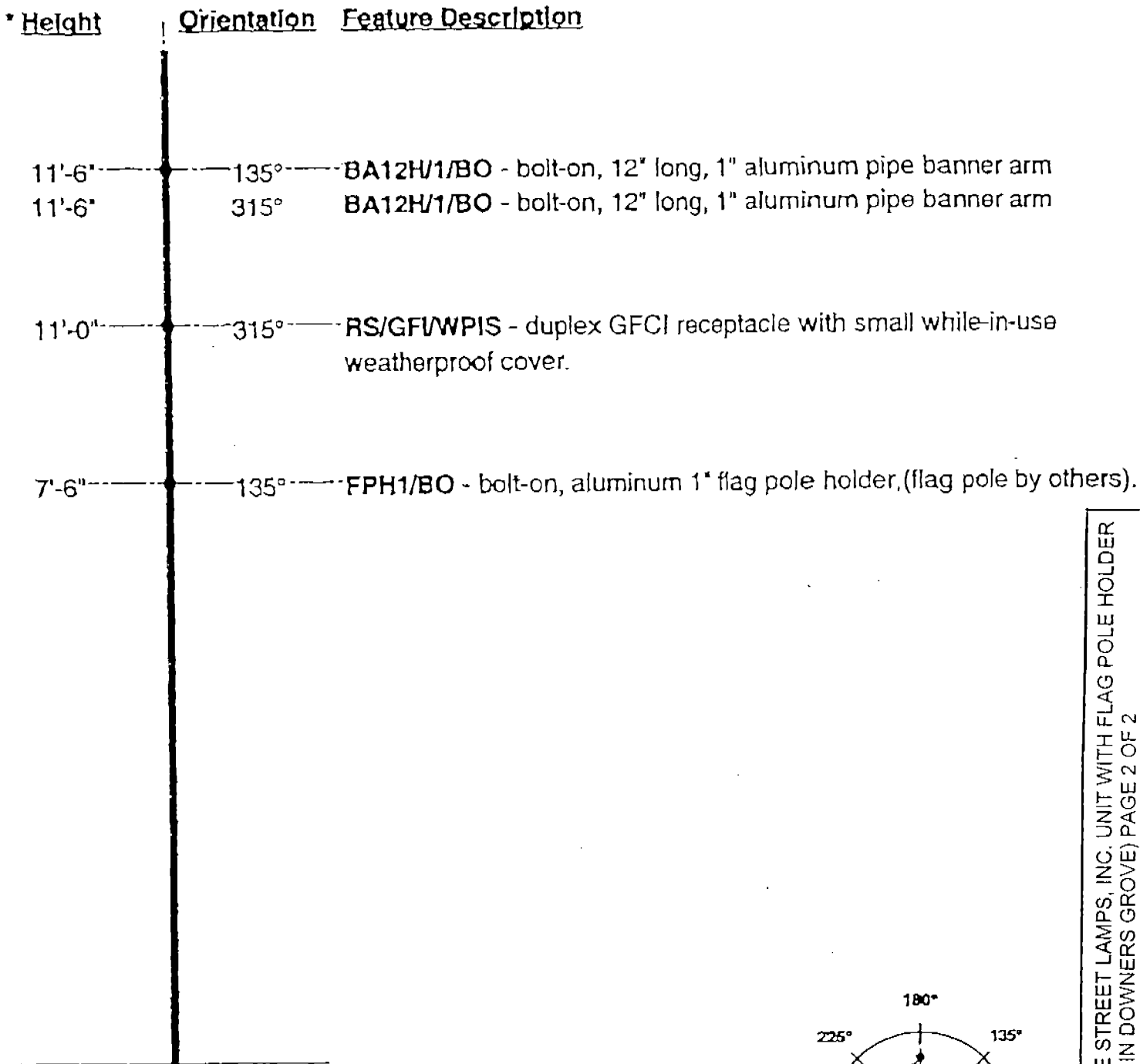

Post	Height
MR12F5/19-CA	12'-0"

\* Height from bottom of base / anchor plate.

sign & date	<b><u>Customer Approval</u></b>
print	_____

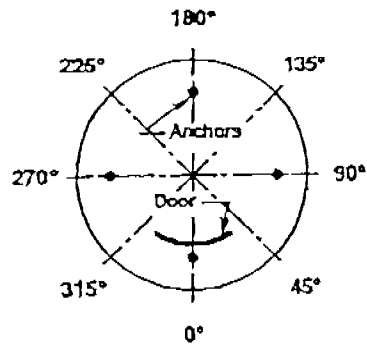

**Orientation**  
(top view)

date: 06-07-99      dwg. no.: OD-4170G

**ANTIQUE Street Lamps, Inc.**  
 P.O. Box 150279      •      Austin, TX 78715-0279  
 (512) 296-3585      •      Fax (512) 295-3330

SHOP DRAWING FOR ANTIQUE STREET LAMPS, INC. UNIT WITH FLAG POLE HOLDER  
(INSTALLED ON MAIN STREET IN DOWNERS GROVE) PAGE 2 OF 2

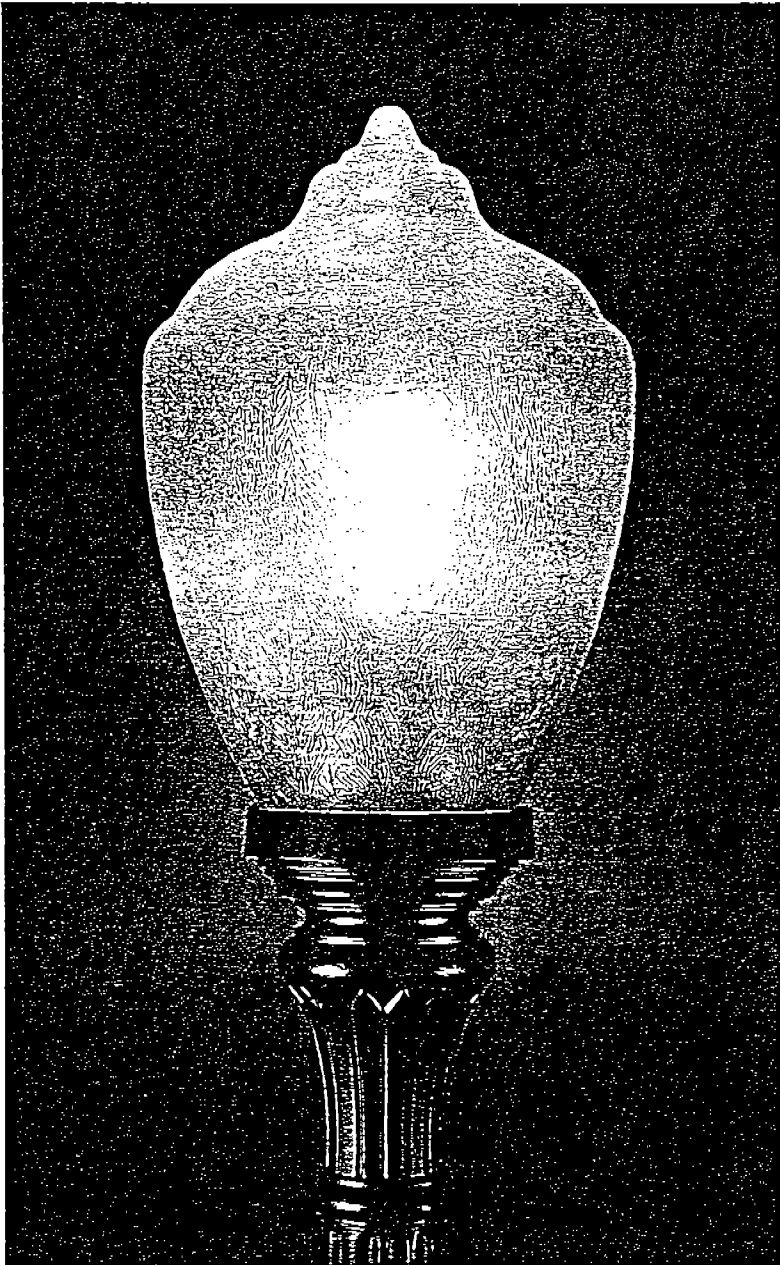

AAT23

**DESCRIPTION**

The acorn styled luminaire shall consist of a decorative luminaire base with an integral globe holder/ballast housing and an acorn shaped globe.

**DIMENSIONS**

Fixture dimensions shall be as detailed on back page.

**MATERIALS**

The luminaire base, ballast housing and globe holder shall be heavy wall, copper free, cast aluminum produced from certified ASTM 356.1 ingot per ASTM B-179-95A or ASTM B26-95, formed true to the pattern with complete detail. Globe material shall be clear textured polycarbonate (standard) or white textured polycarbonate. Internal refractors shall be borosilicate glass and reflectors shall be polished aluminum. Optional finials shall be injection molded polycarbonate and optional decorative bands shall be brass. All hardware shall be stainless steel. All exterior hardware shall be tamper resistant.

**INSTALLATION**

The luminaire shall mount on a 3" O.D. tenon with six 1/4" dia. socket set screws. (Luminaires with a B Series luminaire base shall mount on a 8.25" O.D. ring.) The globe shall be secured to the luminaire by four 1/4" dia. socket set screws. The ballast and socket assembly shall be furnished with a quick disconnect plug and mount on a removable ballast plate. The ballast plate shall be removed by loosening a thumb screw.

**FINISH**

For finish specifications and color options see "Finish" section in catalog.

**LIGHT SOURCE**

Luminaires shall be furnished with an H.I.D. ballast and socket assembly. Luminaire shall be UL listed and labeled as suitable for wet locations. Sockets shall be glazed porcelain, mogul or medium base, with a copper alloy nickel plated screw shell and center contact. Ballast shall be core and coil, high power factor, regulating type.

**CERTIFICATION**

Upon request, manufacturer shall certify the use of 356.1 ingot alloy. Upon request, manufacturer shall supply UL file# and listing information.

CATALOG CUT FOR ANTIQUE STREET LAMPS, INC. AT23 LUMINAIRE

**ANTIQUÉ**  
Street Lamps, Inc.

P.O. Box 150279 • Austin, TX 78715-0279  
(512) 295-3585 • Fax (512) 295-3330

# AT23 Luminaires

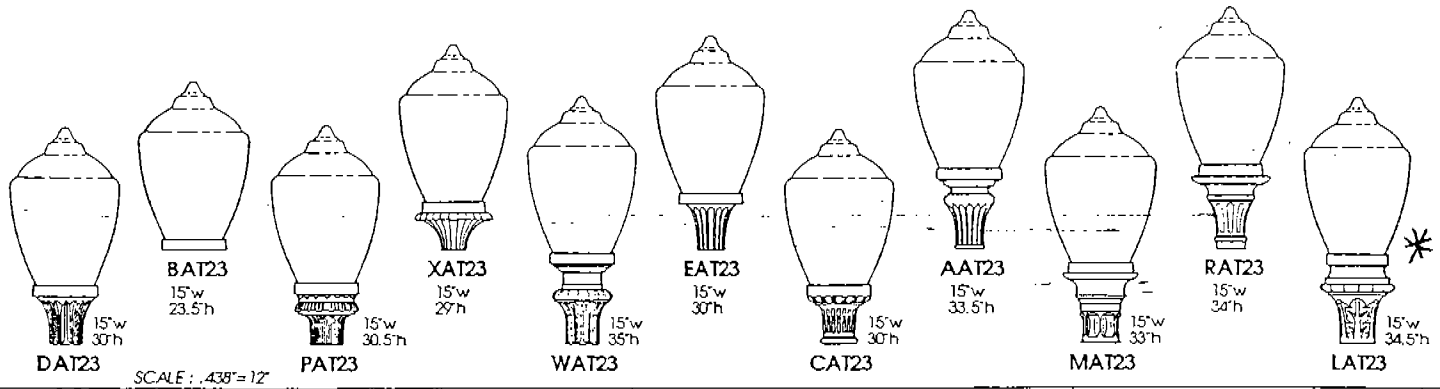

## OPTIONAL TOPS

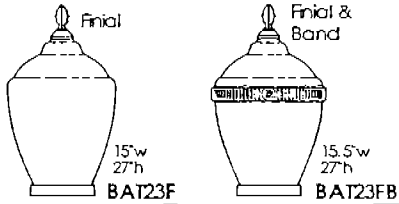

## LUMINAIRE BASES

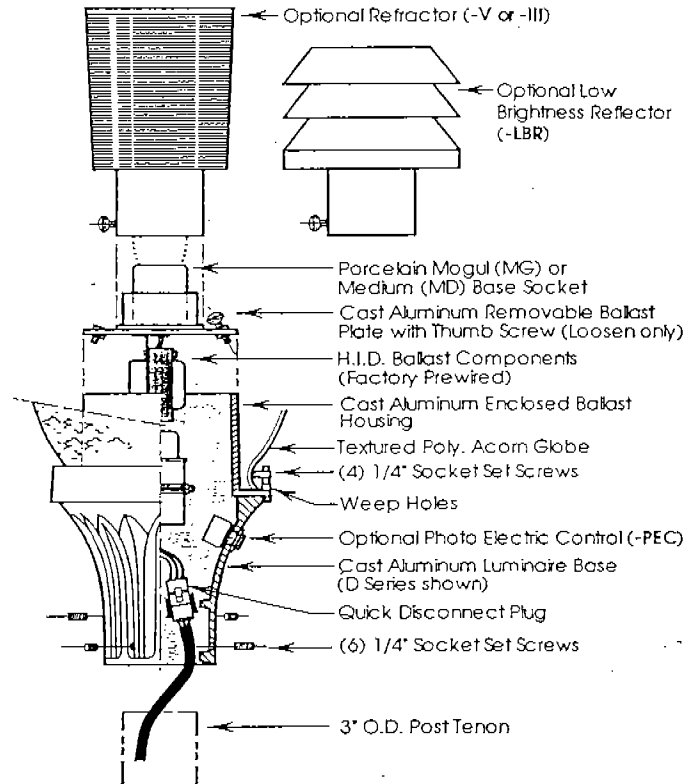
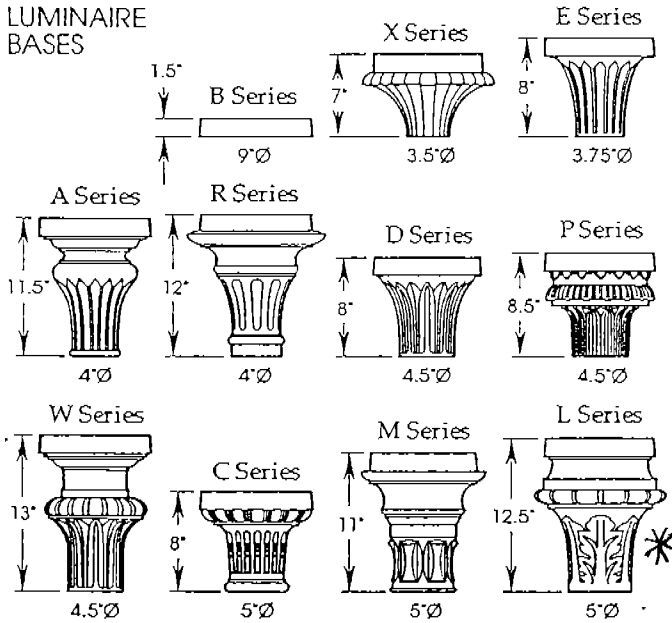

© 1996

SCALE: 1.5"=12"

## ORDERING GUIDE

sample catalog number	luminaire & optional top / finish - light source / voltage - optional equipment - optional equipment
AAT23FB/BK-H100/120-V-PEC	AAT23 FB /BK -H100 /120 -V -PEC

### AT23 Luminaires

Clear Poly. Globes	White Poly. Globes
<input type="checkbox"/> BAT23	<input type="checkbox"/> BAT23W
<input type="checkbox"/> XAT23	<input type="checkbox"/> XAT23W
<input type="checkbox"/> EAT23	<input type="checkbox"/> EAT23W
<input type="checkbox"/> AAT23	<input type="checkbox"/> AAT23W
<input type="checkbox"/> RAT23	<input type="checkbox"/> RAT23W
<input type="checkbox"/> DAT23	<input type="checkbox"/> DAT23W
<input type="checkbox"/> PAT23	<input type="checkbox"/> PAT23W
<input type="checkbox"/> WAT23	<input type="checkbox"/> WAT23W
<input type="checkbox"/> CAT23	<input type="checkbox"/> CAT23W
<input type="checkbox"/> MAT23	<input type="checkbox"/> MAT23W
<input type="checkbox"/> LAT23	<input type="checkbox"/> LAT23W

### Optional Tops

<input type="checkbox"/> F	Finial (as shown)
<input type="checkbox"/> FB	Finial and Band (as shown)

### Finish

<input type="checkbox"/> BK	Black (std.)	<input type="checkbox"/> PP	Prime Painted
<input type="checkbox"/> DB	Dark Bronze	<input type="checkbox"/> DG	Dark Green
		<input type="checkbox"/> CC	Custom Color

(for finish and color options, see Finish section in catalog)

### Light Source

H.I.D. ballast & socket		Std. Base size
<input type="checkbox"/> -H50	50 watt Mercury Vapor	MD
<input type="checkbox"/> -H75	75 watt Mercury Vapor	MD
<input checked="" type="checkbox"/> -H100	100 watt Mercury Vapor	MG
<input type="checkbox"/> -H175	175 watt Mercury Vapor	MG
<input type="checkbox"/> -H250	250 watt Mercury Vapor	MG
<input type="checkbox"/> -M50	50 watt Metal Halide	MD
<input type="checkbox"/> -M70	70 watt Metal Halide	MD
<input type="checkbox"/> -M100	100 watt Metal Halide	MD
<input type="checkbox"/> -M150	150 watt Metal Halide	MD
<input type="checkbox"/> -M175	175 watt Metal Halide	MG
<input type="checkbox"/> -M250*	250 watt Metal Halide	MG
<input type="checkbox"/> -S35	35 watt High Pressure Sodium	MD
<input type="checkbox"/> -S50	50 watt High Pressure Sodium	MD
<input type="checkbox"/> -S70	70 watt High Pressure Sodium	MD
<input type="checkbox"/> -S100	100 watt High Pressure Sodium	MG
<input type="checkbox"/> -S150	150 watt High Pressure Sodium	MG
<input type="checkbox"/> -S250*	250 watt High Pressure Sodium	MG

\* wattages for luminaires with bases over 10" tall only. (consult factory for wattages for B Series Luminaires)

### Voltage

<input type="checkbox"/> /120	<input type="checkbox"/> /208	<input type="checkbox"/> /240	<input type="checkbox"/> /277	<input type="checkbox"/> /480	<input type="checkbox"/> /QV
-------------------------------	-------------------------------	-------------------------------	-------------------------------	-------------------------------	------------------------------

### Optional Equipment

<input type="checkbox"/> -V	6" dia. Borosilicate Glass Refractor with an I.E.S. Type 5 Distribution.
<input checked="" type="checkbox"/> -III	6" dia. Borosilicate Glass Refractor with an I.E.S. Type 3 Distribution.
<input type="checkbox"/> -HSS	House Side Shield
<input type="checkbox"/> -LBR	Anodized Aluminum Low Brightness Reflector Assembly with an I.E.S. Type 5 Distribution.
<input type="checkbox"/> -PEC	Photo Electric Control (120 volt).
<input type="checkbox"/> -PEC2	Photo Electric Control (240 volt).

**ANTIQUe Street Lamps, Inc.**  
 P.O. Box 150279 • Austin, TX 78715-0279 • (512) 295-3585

CATALOG CUT FOR ANTIQUE STREET LAMPS, INC. AT23 LUMINAIRE

Cast Aluminum Posts  
extruded shafts

MARINER Series  
19" dia. base

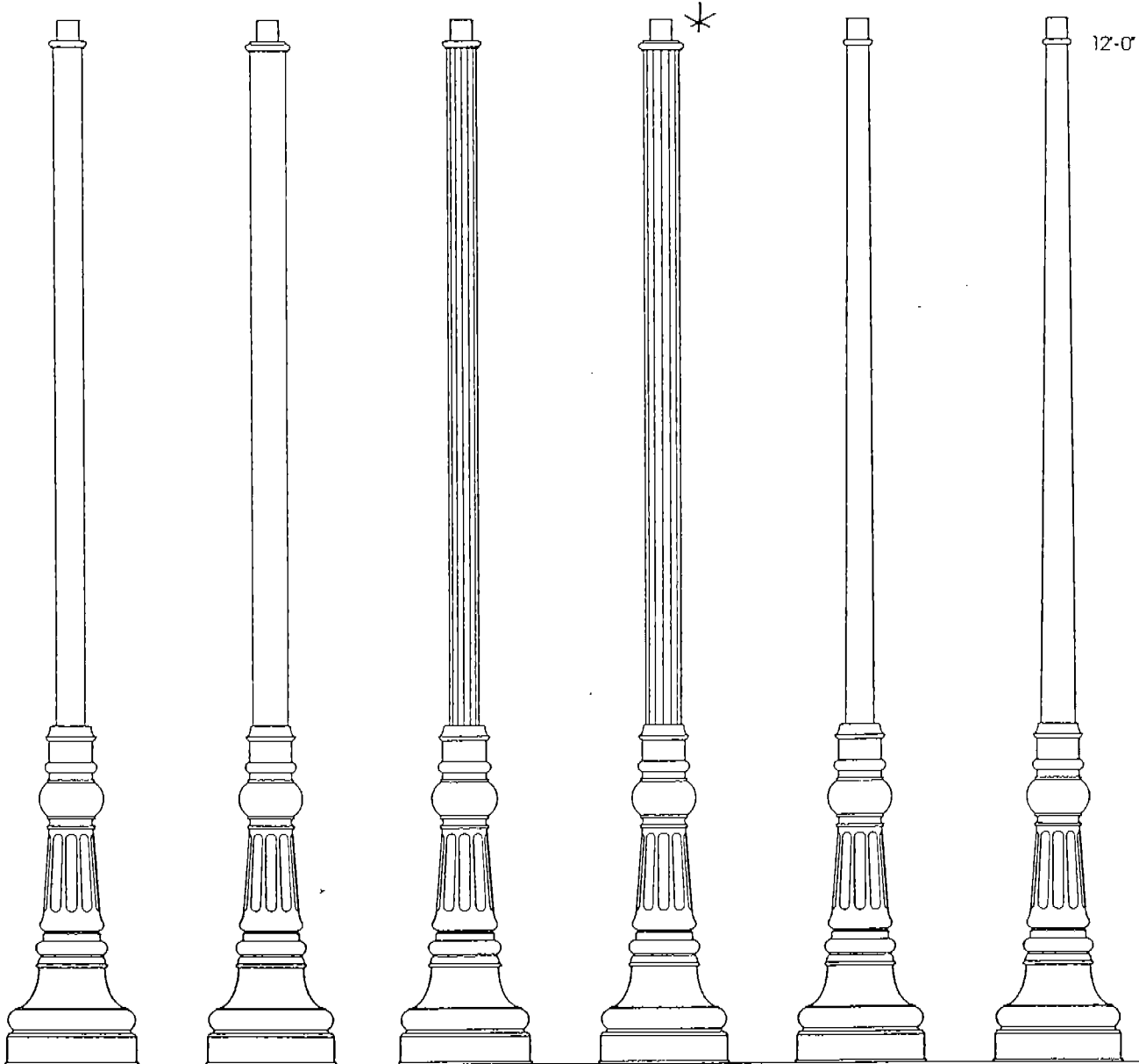

MR12S4/19-CA/finish  
4" dia. smooth shaft  
8', 10', 12', 14'

MR12S5/19-CA/finish  
5" dia. smooth shaft  
10', 12', 14', 16'

MR12F4/19-CA/finish  
4" dia. fluted shaft  
8', 10', 12', 14'

MR12F5/19-CA/finish  
5" dia. fluted shaft  
10', 12', 14', 16'

MR12T4/19-CA/finish  
3"-4" dia. tapered shaft  
8', 10', 12', 14'

MR12T5/19-CA/finish  
3"-5" dia. tapered shaft  
10', 12', 14', 16'

© 1996

CATALOG CUT FOR ANTIQUE STREET LAMPS, INC. MARINER SERIES POLE

## SPECIFICATIONS

**DESCRIPTION** The lighting post shall be all aluminum, one-piece construction, with a classical tapered base design. The shaft shall be \_\_\_\_\_ (insert shaft options from back page). The post shall be Antique Street Lamps' catalog number MRXXXX/19-CA/finish.

**MATERIALS** The base shall be heavy wall, copper free, cast aluminum produced from certified ASTM 356.1 Ingot per ASTM B-179-95a or ASTM B26-95. The straight shafts shall be extruded from aluminum, ASTM 6061 alloy, heat treated to a T6 temper. The tapered shaft shall be extruded from aluminum, ASTM 6063 alloy, spun to a tapered shape, then heat treated to a T6 temper. All hardware shall be temper resistant stainless steel. Anchor bolts to be completely hot dip galvanized.

**CONSTRUCTION** The shaft shall be double welded to the base casting and shipped as one piece for maximum structural integrity. The shaft shall be circumferentially welded inside the base casting at the top of the access door, and externally where the shaft exits the base. All exposed welds below 8' shall be ground smooth. All welding shall be per ANSI/AWS

D1.2-90. All welders shall be certified per Section 5 of ANSI/AWS D1.2-90.

**DIMENSIONS** The post shall be X'-XX" in height with a 19" diameter base. The shaft diameter shall be XX". (see back page) At the top of the post, an integral 3" O.D. tenon with a transitional donut shall be provided for luminaire mounting.

**INSTALLATION** The post shall be provided with four, hot dip galvanized L-type anchor bolts to be installed on a 14" diameter bolt circle. A door shall be provided in the base for anchorage and wiring access. A grounding screw shall be provided inside the base opposite the door.

For finish specifications and color options, see "Finish" section in catalog.

ANTIQUE Street Lamps, Inc.

P.O. Box 150279 • Austin, TX 78715-0279 • (512) 295-3585 • Fax (512) 295-3330

# MARINER Series Cast Aluminum Posts

## SHAFT OPTIONS

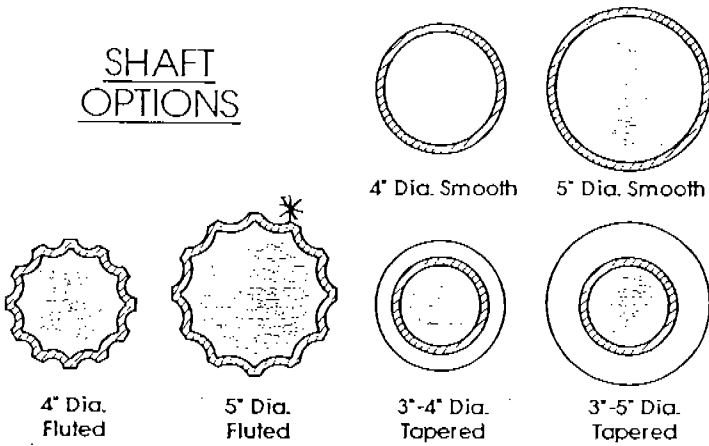

3" O.D. x 3" High Tenon

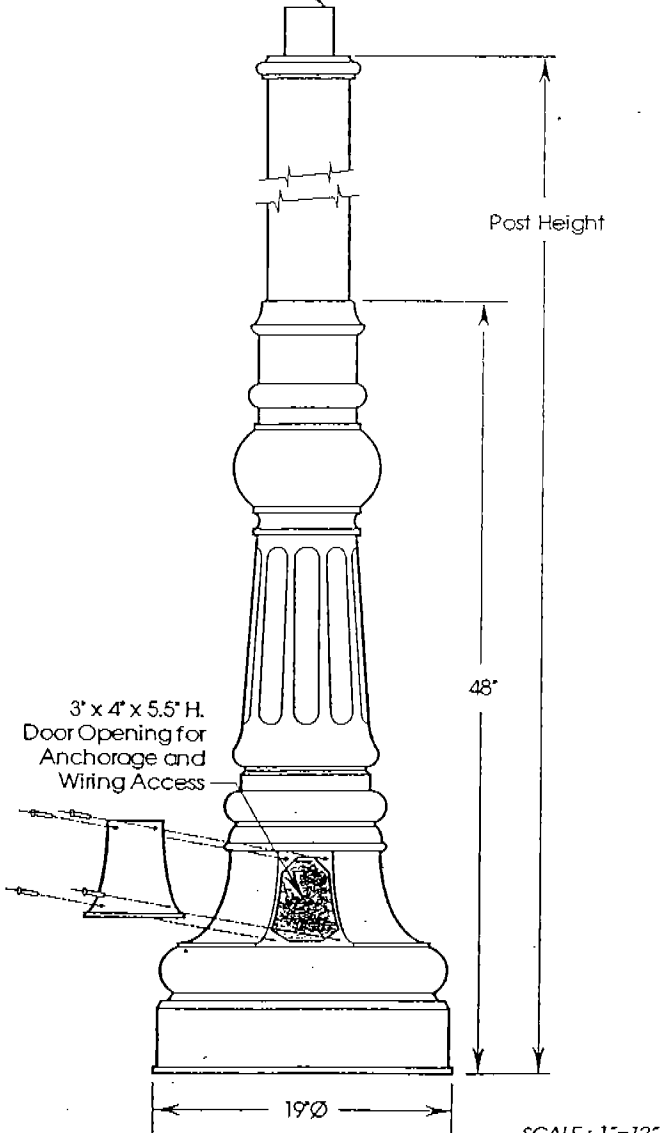

## ORDERING GUIDE

sample catalog number

MR12S4/19 - CA/BK - RS/GFI/WPIS

Post - material/finish - options

MARINER 12" - Cast Aluminum - Weatherproof  
Smooth 4" shaft - Black - Receptacle  
19" dia. base - at Top (of post)

**Post** (check appropriate boxes, add height in blank)

Catalog #	Shaft Type	Heights
<input type="checkbox"/> MR_S4/19	4" dia. smooth	8', 10', 12', 14'
<input type="checkbox"/> MR_S5/19	5" dia. smooth	10', 12', 14', 16'
<input type="checkbox"/> MR_F4/19	4" dia. fluted	8', 10', 12', 14'
<input checked="" type="checkbox"/> MR_F5/19	5" dia. fluted	10', 12', 14', 16'
<input type="checkbox"/> MR_T4/19	3"-4" dia. tapered	8', 10', 12', 14'
<input type="checkbox"/> MR_T5/19	3"-5" dia. tapered	10', 12', 14', 16'

### Material/Finish

Catalog Suffix	Description
<input checked="" type="checkbox"/> -CA/BK	Cast Aluminum/Black (std.)
<input type="checkbox"/> -CA/DG	Cast Aluminum/Dark Green
<input type="checkbox"/> -CA/DB	Cast Aluminum/Dark Bronze
<input type="checkbox"/> -CA/PP	Cast Aluminum/Prime Painted
<input type="checkbox"/> -CA/CC	Cast Aluminum/Custom Color

(for complete finish and color options, see "Finish" section in catalog)

### Optional Equipment

Catalog Suffix	Description
<input checked="" type="checkbox"/> -_____	Receptacles (see Accessories section)
<input type="checkbox"/> -_____	Banner Arms (see Accessories section)
<input checked="" type="checkbox"/> -_____	Flag Pole Holders (see Accessories section)
<input type="checkbox"/> -_____	Custom Logos (see Accessories section)
<input type="checkbox"/> -_____	Signage (see Signage section)

(for optional equipment not found in catalog, consult factory)

## ANCHORAGE GUIDE

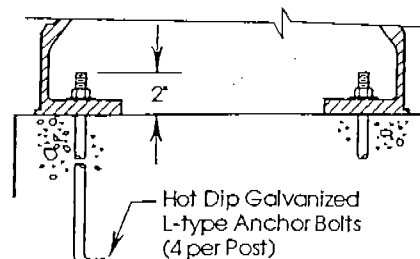
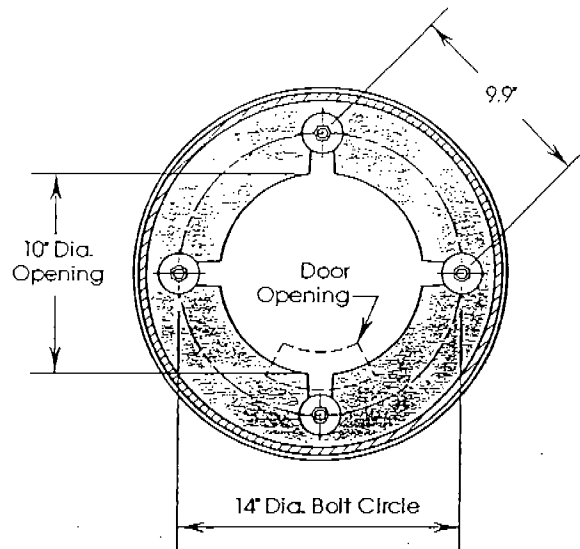

SCALE: 1.25"=12"

CATALOG CUT FOR ANTIQUE STREET LAMPS, INC. MARINER SERIES POLE

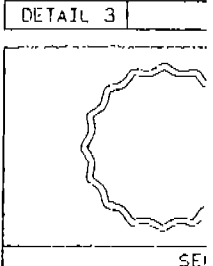
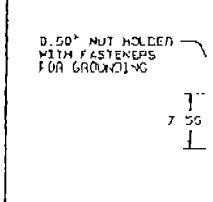
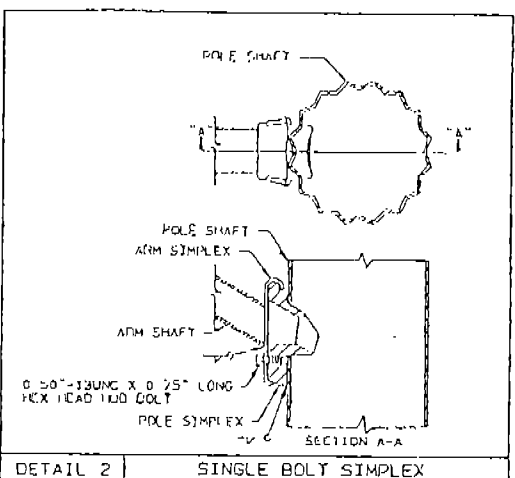
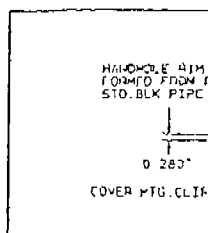
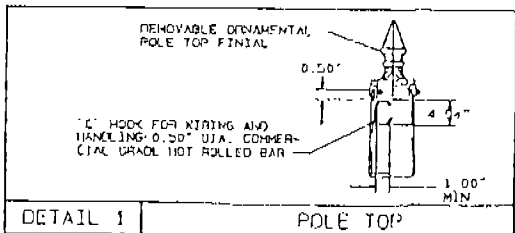
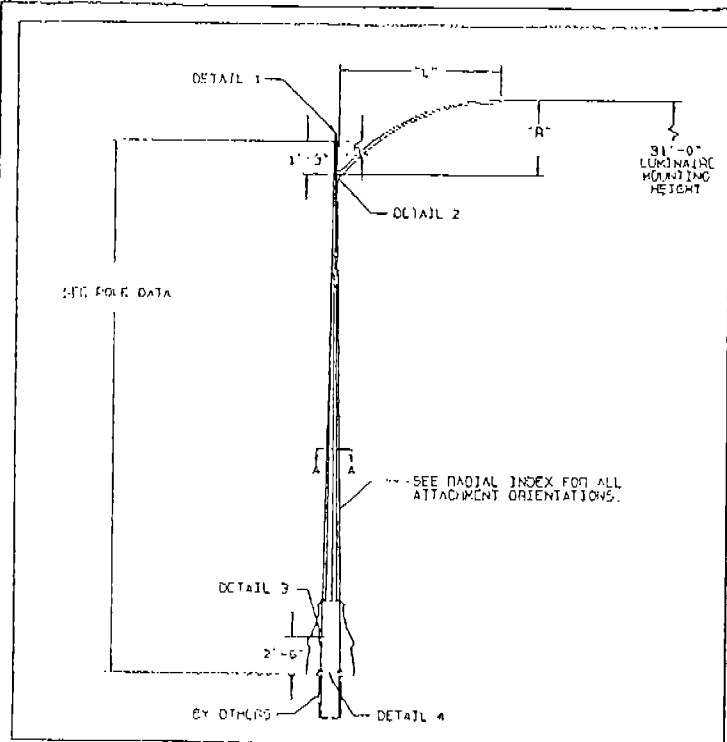

MATERIAL DATA					
COMPONENT	ASTM DESIGNATION	MIN. YIELD (KSI)	COMPONENT	ASTM DESIGNATION	MIN. YIELD (KSI)
POLE SHAFT	A500 GR. A	58	GALVANIZING	A153	
ARM PIPE	A500 GR. A	58	SIMPLEX ATTACHMENT	A27 65-35	
POLE BASE	A500 GR. A	58			

FINISH: VALMONT SPECIFICATION F203A  
 BASE COAT: HOT-DIP GALVANIZE TO ASTM A129  
 FINISH TGIC OR URETHANE POLYESTER POWDER  
 COLOR: BLACK

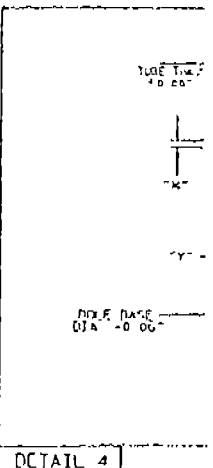

POLE AND SIGNAL ARM DATA																	
ITEM	QTY.	POLE TUBE				POLE BASE				ANCHOR BOLT			LUMINAIRE ARM TUBE				
		BASE DIA. (IN)	TOP DIA. (IN)	LENGTH (FT)	GUAGE OR THICK (IN)	SQUARE (IN)	BOLT CIRCLE (IN)	THK. (IN)	HOLE/SLOT (IN)	DIA. (IN)	LENGTH (IN)	HOOK (IN)	HEAD LENGTH (IN)	PIPE O.D. (IN)	WALL THK. (IN)	RISE HEIGHT (FT)	SPAN (FT)
1	5	8.00	3.00	30.00	11	11.50	11.00	0.08	1.13 X 1.89	1.00	36.00	4.00	6.00	2.28	0.154	2.25	8.00

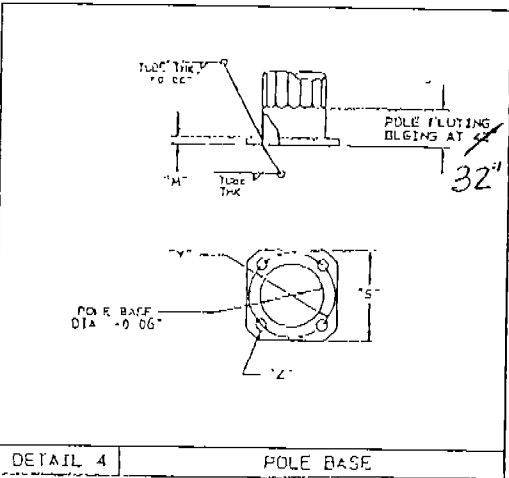
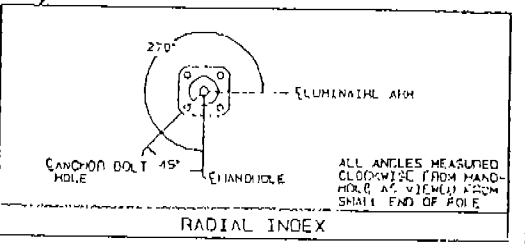
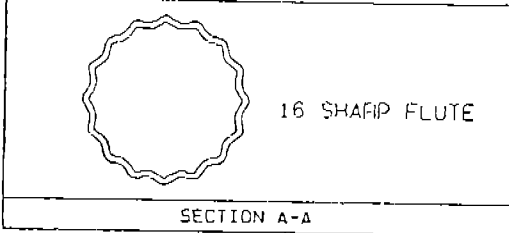
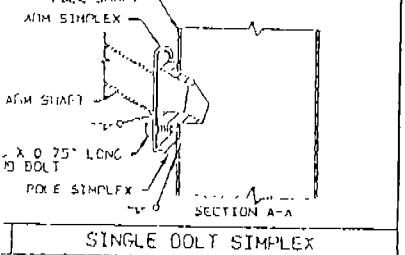
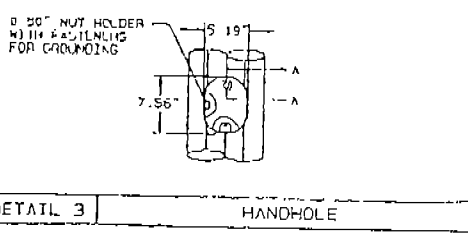
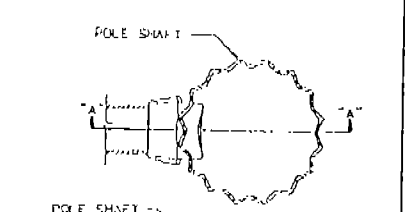
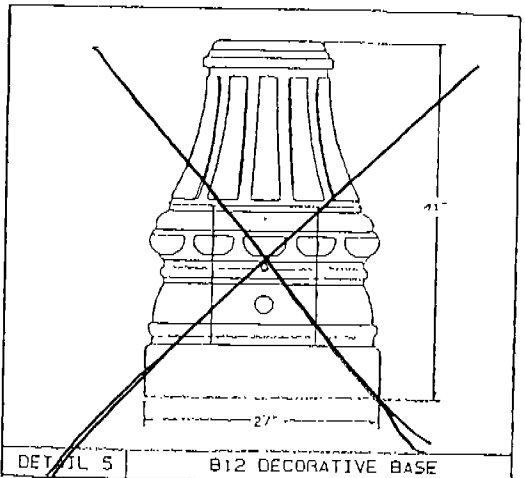
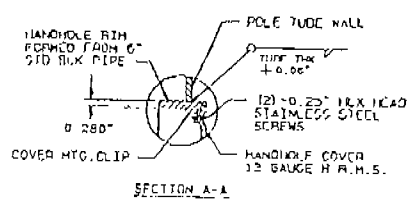
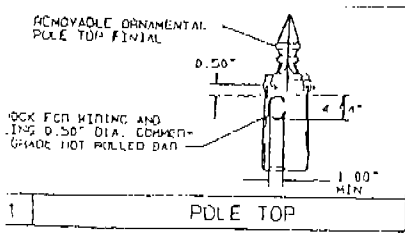

THORNE ELECTRIC, INC.  
 P.O. BOX 321  
 WHEATON, ILL. 60189  
 CONTRACT # 00-122  
 JOB # Dowhens Grove CBD3

REV	LUMINAIRE ARM TUBE				
	FLUTE AD FROM (IN)	TYPE O.D. (IN)	WALL THK. (IN)	RISE (HEIGHT) (FT)	SPAN (FT)
0	6.00	2.08	0.154	2.25	8.00

REV	DATE	REVISION	 <b>VALMONT</b> <small>VALMONT INDUSTRIES INC.          VALLEY INDUSTRIAL COURT          (602) 379-2201</small>
0	05/08/00	DRAWN JLE	

# 'B' SERIES BASE ASSEMBLIES

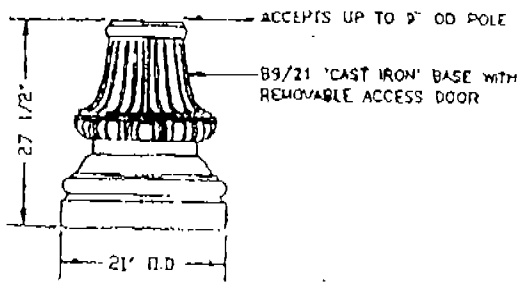

SERIES B9/21  
(CLAM SHELL DESIGN)

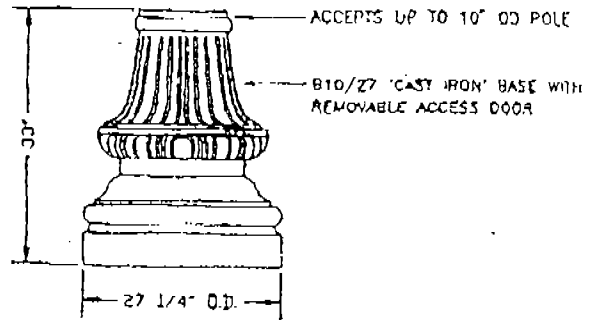

SERIES B10/27  
(CLAM SHELL DESIGN)

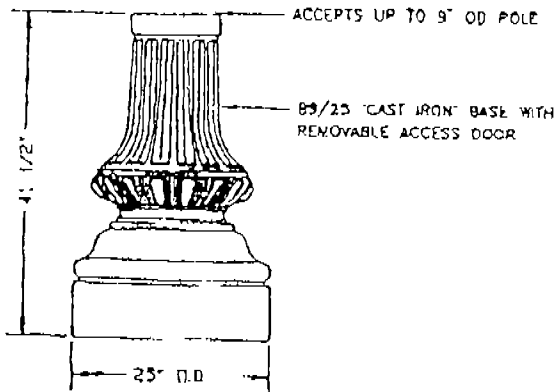

SERIES B9/25  
(CLAM SHELL DESIGN)

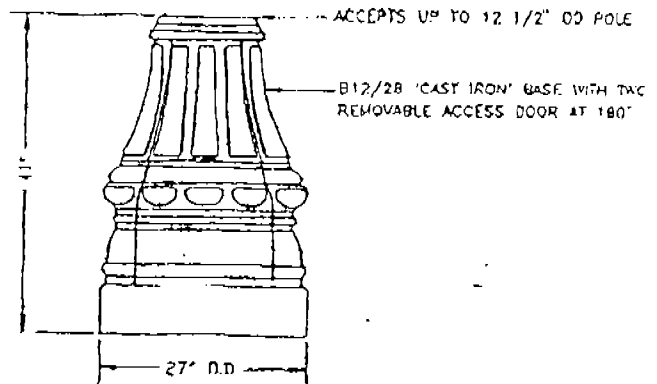

SERIES B12/28  
(CLAM SHELL DESIGN)



20570 AUBREY LANE, EUGENE, OR 97402  
 (503) 688-7741, FAX (503) 681-0981

PROPOSAL FOR

CBD Phase 4 Streetlight Purchase

TO: THE VILLAGE OF DOWNERS GROVE  
PUBLIC WORKS FACILITY  
5101 WALNUT AVENUE  
DOWNERS GROVE, ILLINOIS 60515

1. Following is the Proposal of:

Name: Thorne Electric, Inc.

Address: P.O. Box 321 Wheaton, IL 60189

Phone No.: 630-668-4853

for the improvement which plans and specifications are designated as

CBD Phase 4 Streetlight Purchase, Project #20-00

- 2. The specifications for the proposed improvement are those prepared by the Village of Downers Grove, dated November, 2000.
- 3. When submitting this Proposal, the undersigned declares that the only person or parties interested in the Proposal as principals are those named herein; and that the proposal is made without collusion with any other person, firm or corporation.

The bidder states the following items of work will not be performed by his own organization. List items to be subcontracted as well as the names, addresses and phone numbers of the subcontractors.

TYPE OF WORK	CONTRACTOR	ADDRESS	PHONE #

- 4. The undersigned further declares that he has carefully examined the Proposal, Plans, Specifications, Standard Specifications, and form of contract, and that he has inspected in detail the site of the proposed work; and that he has familiarized himself with all of the local conditions affecting the contract and the detailed requirements of construction, and understands that in making this Proposal he waives all rights to plead any misunderstanding regarding the same.
- 5. The undersigned further understands and agrees that if this Proposal is accepted he is to furnish and provide all necessary machinery, tools, apparatus, labor, materials, and to do all work as specified in the Specifications of this Proposal, except such materials as are to be furnished by the Owner; in the manner and at the time therein prescribed, and in accordance with the requirements as set forth.
- 6. The undersigned agrees that he understands the quantities mentioned are estimated and that they are subject to increase or decrease, and that the undersigned will take in full payment therefore the amount of the summation of the actual quantities as finally determined multiplied by the unit prices shown in the Schedule of Prices outlined herein.

7. The undersigned further agrees that the unit prices submitted herein are for the purposes of obtaining a gross sum and for the use of computing the values of additions or deductions to the Plan Quantities; that if there is any discrepancy between the gross sum bid and that resulting from the summation of the quantities multiplied by their respective unit prices, the latter shall apply.
8. The undersigned further agrees that if the Owner decides to increase or decrease the size of the project; or otherwise alter the project; the undersigned shall perform the work as altered, increased, or decreased at the contract unit prices stated herein.
9. The undersigned further agrees that the Owner may at any time during the progress of the work covered by this Proposal, order other work or materials relative to the project, and that such work and materials which do not appear in this Proposal as a specified item accompanied by a unit price, or which are not included under the bid price for other items in this contract, shall be performed as extra work per Art. 109.04 of the current Standard Specifications for Road and Bridge Construction and compensation shall be paid in accordance with Art. 109.04 of the referenced Standard specifications.
10. The undersigned further agrees to execute the Contract for this improvement and present the same to the Owner within ten (10) calendar days after the date of notice of the award of the Contract to him.
11. The undersigned further agrees that he and his Surety will execute and present within ten (10) calendar days after the receipt of Notice of Award of Contract, a Performance Bond and Labor and Materials Payment Bond satisfactory to and in the form prescribed by the Owner in the penal sum of the full amount of the Contract guaranteeing the faithful performance and completion of all work in accordance with the terms of the Specifications and Special Provisions of the Contract.
12. The undersigned further agrees to begin work not later than ten (10) calendar days after receipt of the Notice to Proceed, or earlier, if approval is granted by the Engineer. **The Contractor agrees to then prosecute the work in such a manner and with sufficient materials, equipment, and labor as will insure completion of the Project by June 1, 2001, unless additional time shall be granted by the Owner in accordance with the general requirements, it being understood and agreed that the completion within the time limit heretofore specified is an essential part of the Proposal.**

Should the contractor fail to complete the work on or before the completion date established herein, or within such extended time as may have been allowed by the Village, the contractor shall be liable to the Village in the amount of **\$200 for each calendar day or portion thereof of overrun** in the contract time or such extended time as may have been allowed by the Village, not as a penalty, but as liquidated damages.

In fixing the liquidated damage amount as described herein, the Village's desire is to establish an agreed calculation of the Village's loss in the event of delay, as the Village's actual cannot be predetermined, would be difficult to ascertain and could be a matter of argument and unprofitable litigation. This said calculation is agreed as an equitable rule for measurement of the Village's actual loss and fairly takes into account the impact of the delay of this project on other Village project(s). The Village shall not be required to prove any actual loss in order to recover the liquidated damages described herein, as such damages are difficult to ascertain. The parties agree that no provision of this section shall be construed to imply a penalty.

13. Accompanying this Proposal is a bid deposit in the form of a Cash Deposit, Certified Check, Bank Cashier's Check, or Bid Bond for five percent (5%) of the bid. The bid deposit shall be made payable to the Village of Downers Grove.

If this Proposal is accepted and the undersigned fails to execute a contract, and a Labor and Materials Payment Bond as prescribed herein, it is hereby mutually agreed that the amount of the bid deposit shall become the property of the Owner and shall be considered a payment of damages due to delay and other causes suffered by the Owner because of a failure to execute the Contract and Performance Bonds. If the requirements of the Contract and Performance Bond are met, the bid deposit shall be returned to the undersigned.

## BID BOND

(Percentage)

Know all persons by these presents, That we Thorne Electric, Inc.

of P. O. Box 321, Wheaton, IL 60189, hereinafter referred to as the Principal,

and National Fire Insurance Company of Hartford, CNA Plaza, Chicago, IL as Surety, are held and firmly bound unto

Village of Downers Grove

of 5101 Walnut Avenue, Downers Grove, IL 60515-4776, hereinafter referred to as the

Obligee, in the sum of Five Percent of the Amount of Bid

Dollars ( **5% of the Bid** ), for the payment of which we bind ourselves, our legal representatives, successors and assigns, jointly and severally, firmly by these presents.

Whereas, Principal has submitted or is about to submit a proposal to Obligee on a contract for

**CBD Phase 4 Streetlight Purchase Project # 20-00**

Now, Therefore, if the said contract be awarded to Principal and Principal shall, within such time as may be specified, enter into the contract in writing and give such bond or bonds as may be specified in the bidding or contract documents with surety acceptable to Obligee: or if Principal shall fail to do so, pay to Obligee the damages which Obligee may suffer by reason of such failure not exceeding the penalty of this bond, then this obligation shall be void; otherwise to remain in full force and effect.

Signed, Sealed and Dated this 13th day of December 2000.

Principal

Thorne Electric, Inc.

BY:

Surety

National Fire Insurance Company of Hartford

BY: Anna Marie Garrod

Anna Marie Garrod, Agent & Attorney-in-fact

State of Illinois

I, LAURA LEE DINAN

County of DuPage

Notary Public of DuPage County, in the State of Illinois, do

hereby certify that ANNA MARIE GARROD

Attorney-in-fact, of the National Fire Insurance Company of Hartford,

who is personally known to me to be the same person whose name

is subscribed to the foregoing instrument, appeared before me this day in

person, and acknowledged that he signed, sealed and delivered said instrument,

for and on behalf of the National Fire Insurance Company of Hartford,

for the uses and purposes therein set forth.

Given under my hand and notarial seal at my office in the City of Wheaton

in said County, this 13TH day of DECEMBER A.D. 2000.

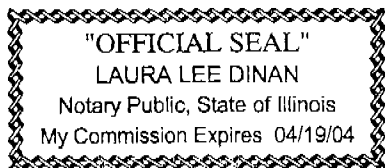

Laura Lee Dinan  
 Notary Public.

-----

# POWER OF ATTORNEY APPOINTING INDIVIDUAL ATTORNEY-IN-FACT

Know All Men By These Presents, That CONTINENTAL CASUALTY COMPANY, an Illinois corporation, NATIONAL FIRE INSURANCE COMPANY OF HARTFORD, a Connecticut corporation, AMERICAN CASUALTY COMPANY OF READING, PENNSYLVANIA, a Pennsylvania corporation (herein collectively called "the CCC Surety Companies"), are duly organized and existing corporations having their principal offices in the City of Chicago, and State of Illinois, and that they do by virtue of the signature and seals herein affixed hereby make, constitute and appoint

Robert F. Haeger, Kurt A. Parent, Michael J. Reilly, Anna Marie Garrod, Barbara J. Pitcher, Individually

of Wheaton, Illinois

their true and lawful Attorney(s)-in-Fact with full power and authority hereby conferred to sign, seal and execute for and on their behalf bonds, undertakings and other obligatory instruments of similar nature

- In Unlimited Amounts -

and to bind them thereby as fully and to the same extent as if such instruments were signed by a duly authorized officer of their corporations and all the acts of said Attorney, pursuant to the authority hereby given are hereby ratified and confirmed.

This Power of Attorney is made and executed pursuant to and by authority of the By-Laws and Resolutions, printed on the reverse hereof, duly adopted, as indicated, by the Boards of Directors of the corporations.

In Witness Whereof, the CCC Surety Companies have caused these presents to be signed by their Group Vice President and their corporate seals to be hereto affixed on this 28th day of August, 2000.



CONTINENTAL CASUALTY COMPANY  
NATIONAL FIRE INSURANCE COMPANY OF HARTFORD  
AMERICAN CASUALTY COMPANY OF READING, PENNSYLVANIA

Michael Gengler Group Vice President

State of Illinois, County of Cook, ss:

On this 28th day of August, 2000, before me personally came

Michael Gengler, to me known, who, being by me duly sworn, did depose and say: that he resides in the City of Chicago, State of Illinois; that he is a Group Vice President of CONTINENTAL CASUALTY COMPANY, NATIONAL FIRE INSURANCE COMPANY OF HARTFORD, and AMERICAN CASUALTY COMPANY OF READING, PENNSYLVANIA described in and which executed the above instrument; that he knows the seals of said corporations; that the seals affixed to the said instrument are such corporate seals; that they were so affixed pursuant to authority given by the Boards of Directors of said corporations and that he signed his name thereto pursuant to like authority, and acknowledges same to be the act and deed of said corporations.

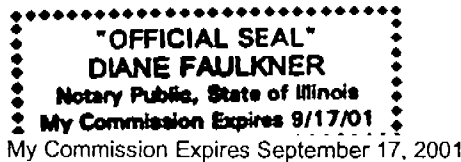

Diane Faulkner Notary Public

## CERTIFICATE

I, Mary A. Ribikawskis, Assistant Secretary of CONTINENTAL CASUALTY COMPANY, NATIONAL FIRE INSURANCE COMPANY OF HARTFORD, and AMERICAN CASUALTY COMPANY OF READING, PENNSYLVANIA do hereby certify that the Power of Attorney herein above set forth is still in force, and further certify that the By-Law and Resolution of the Board of Directors of each corporation printed on the reverse hereof are still in force. In testimony whereof I have hereunto subscribed my name and affixed the seals of the said corporations this 13TH day of DECEMBER, 2000



CONTINENTAL CASUALTY COMPANY  
NATIONAL FIRE INSURANCE COMPANY OF HARTFORD  
AMERICAN CASUALTY COMPANY OF READING, PENNSYLVANIA

Mary A. Ribikawskis Assistant Secretary

## Authorizing By-Laws and Resolutions

ADOPTED BY THE BOARD OF DIRECTORS OF CONTINENTAL CASUALTY COMPANY:

This Power of Attorney is made and executed pursuant to and by authority of the following By-Law duly adopted by the Board of Directors of the Company.

### **"Article IX—Execution of Documents**

Section 3. Appointment of Attorney-in-fact. The Chairman of the Board of Directors, the President or any Executive, Senior or Group Vice President may, from time to time, appoint by written certificates attorneys-in-fact to act in behalf of the Company in the execution of policies of insurance, bonds, undertakings and other obligatory instruments of like nature. Such attorneys-in-fact, subject to the limitations set forth in their respective certificates of authority, shall have full power to bind the Company by their signature and execution of any such instruments and to attach the seal of the Company thereto. The Chairman of the Board of Directors, the President or any Executive, Senior or Group Vice President or the Board of Directors, may, at any time, revoke all power and authority previously given to any attorney-in-fact."

This Power of Attorney is signed and sealed by facsimile under and by the authority of the following Resolution adopted by the Board of Directors of the Company at a meeting duly called and held on the 17th day of February, 1993.

"Resolved, that the signature of the President or any Executive, Senior or Group Vice President and the seal of the Company may be affixed by facsimile on any power of attorney granted pursuant to Section 3 of Article IX of the By-Laws, and the signature of the Secretary or an Assistant Secretary and the seal of the Company may be affixed by facsimile to any certificate of any such power and any power or certificate bearing such facsimile signature and seal shall be valid and binding on the Company. Any such power so executed and sealed and certified by certificate so executed and sealed shall, with respect to any bond or undertaking to which it is attached, continue to be valid and binding on the Company."

ADOPTED BY THE BOARD OF DIRECTORS OF AMERICAN CASUALTY COMPANY OF READING, PENNSYLVANIA:

This Power of Attorney is made and executed pursuant to and by authority of the following By-Law duly adopted by the Board of Directors of the Company.

### **"Article VI—Execution of Obligations and Appointment of Attorney-in-Fact**

Section 2. Appointment of Attorney-in-fact. The Chairman of the Board of Directors, the President or any Executive, Senior or Group Vice President may, from time to time, appoint by written certificates attorneys-in-fact to act in behalf of the Company in the execution of policies of insurance, bonds, undertakings and other obligatory instruments of like nature. Such attorneys-in-fact, subject to the limitations set forth in their respective certificates of authority, shall have full power to bind the Company by their signature and execution of any such instruments and to attach the seal of the Company thereto. The President or any Executive, Senior or Group Vice President may at any time revoke all power and authority previously given to any attorney-in-fact."

This Power of Attorney is signed and sealed by facsimile under and by the authority of the following Resolution adopted by the Board of Directors of the Company at a meeting duly called and held on the 17th day of February, 1993.

"Resolved, that the signature of the President or any Executive, Senior or Group Vice President and the seal of the Company may be affixed by facsimile on any power of attorney granted pursuant to Section 2 of Article VI of the By-Laws, and the signature of the Secretary or an Assistant Secretary and the seal of the Company may be affixed by facsimile to any certificate of any such power and any power or certificate bearing such facsimile signature and seal shall be valid and binding on the Company. Any such power so executed and sealed and certified by certificate so executed and sealed shall, with respect to any bond or undertaking to which it is attached, continue to be valid and binding on the Company."

ADOPTED BY THE BOARD OF DIRECTORS OF NATIONAL FIRE INSURANCE COMPANY OF HARTFORD:

This Power of Attorney is made and executed pursuant to and by authority of the following Resolution duly adopted on February 17, 1993 by the Board of Directors of the Company.

"RESOLVED: That the President, an Executive Vice President, or any Senior or Group Vice President of the Corporation may, from time to time, appoint, by written certificates, Attorneys-in-Fact to act in behalf of the Corporation in the execution of policies of insurance, bonds, undertakings and other obligatory instruments of like nature. Such Attorney-in-Fact, subject to the limitations set forth in their respective certificates of authority, shall have full power to bind the Corporation by their signature and execution of any such instrument and to attach the seal of the Corporation thereto. The President, an Executive Vice President, any Senior or Group Vice President or the Board of Directors may at any time revoke all power and authority previously given to any Attorney-in-Fact."

This Power of Attorney is signed and sealed by facsimile under and by the authority of the following Resolution adopted by the Board of Directors of the Company at a meeting duly called and held on the 17th day of February, 1993.

"RESOLVED: That the signature of the President, an Executive Vice President or any Senior or Group Vice President and the seal of the Corporation may be affixed by facsimile on any power of attorney granted pursuant to the Resolution adopted by this Board of Directors on February 17, 1993 and the signature of a Secretary or an Assistant Secretary and the seal of the Corporation may be affixed by facsimile to any certificate of any such power, and any power or certificate bearing such facsimile signature and seal shall be valid and binding on the Corporation. Any such power so executed and sealed and certified by certificate so executed and sealed, shall with respect to any bond or undertaking to which it is attached, continue to be valid and binding on the Corporation."

(Attach Bid Deposit hereto)

14. The undersigned submits herewith his Schedule of Prices covering the work to be performed under this Proposal. The undersigned understands that he must show in the Schedule of Prices the unit prices for which he proposes to perform each item of work, that the extensions must be made by him, and that if not so done, his Proposal may be rejected as irregular.
15. To comply with Chapter 38 of the Illinois Revised Statute 33-E11, every bid submitted to the Village of Downers Grove shall have a Contractors Certificate signed by the contractor submitting the bid stating that the contractor is not barred from bidding this contract as a result of violations of Sections 33E-3 or 33E-4 of Chapter 38.

To comply with Chapter 24 of the Illinois Revised Statute 11-42.1-1, every bid submitted to the Village of Downers Grove shall have a Contractors Certificate signed by the contractor submitting the bid stating that the contractor is not delinquent in payment of any tax administered by the Illinois Department of Revenue.

16. The undersigned agrees that if awarded the Contract, he will comply with all requirements as herein set forth.

16.1 IF INDIVIDUAL BUSINESS:

\_\_\_\_\_  
(Signature of Bidder)

\_\_\_\_\_  
(Business Address)

16.2 IF A CO-PARTNERSHIP:

\_\_\_\_\_  
(Firm Name)

\_\_\_\_\_  
(Business Address)

Names and addresses of all firm members:

\_\_\_\_\_  
\_\_\_\_\_  
\_\_\_\_\_  
\_\_\_\_\_

16.3 IF A CORPORATION:

Thorne Electric, Inc.  
(Corporate Name)

P.O. Box 321 Wheaton, IL 60189  
(Business Address)

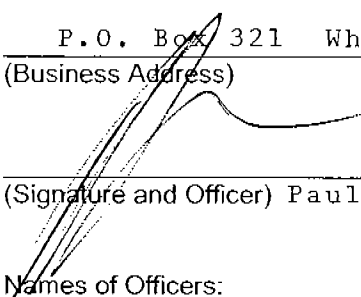
  
(Signature and Officer) Paul H. Thorne, Manager

Names of Officers: Marion P. Thorne  
(President)

Lolita Thorne  
(Secretary)

Cynthia D. Thorne  
(Treasurer)

ATTEST:

  
(Secretary) Kenneth D. Thorne, Superintendent

# Thorne Electric Inc.

P.O. BOX 321 • WHEATON, ILLINOIS 60189

PHONE: 668-4853

December 11, 2000

## Signature Authorization;

Paul H. Thorne (1) and Kenneth D. Thorne (2) are hereby given the authority to sign waivers and contracts in our absence.

President - Marion P. Thorne

Marion P. Thorne

Secretary - Lolita Thorne

Lolita Thorne

Treasurer - Cynthia D. Thorne

Cynthia D. Thorne

Shelly Thorne

Notary

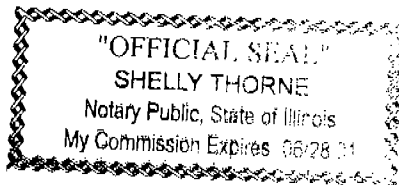

Manager - Paul H. Thorne

(1) Paul H. Thorne

Superintendent - Kenneth D. Thorne

(2) Kenneth D. Thorne

VILLAGE OF DOWNERS GROVE  
 DEPARTMENT OF PUBLIC WORKS  
 CBD PHASE 4 STREETLIGHT PURCHASE

PROJECT 20-00

SCHEDULE OF PRICES

ITEM NO.	PAY ITEM	UNIT	QUAN-TITY	UNIT PRICE	TOTAL AMOUNT
1	NEW LUMINAIRE AND 12' STREETLIGHT POLE WITH BANNER ARMS	EACH	42	1,850.00	77,700.00
2	NEW LUMINAIRE AND 12' STREETLIGHT POLE WITH FLAGPOLE HOLDER	EACH	36	1,850.00	66,600.00
3	NEW LUMINAIRE AND 12' STREETLIGHT POLE WITH FLAGPOLE HOLDER AND 60 AMP OUTLET	EACH	4	1,850.00	7,400.00
4	NEW LUMINAIRE AND 29' STREETLIGHT POLE WITH MAST ARM AND DECORATIVE SKIRT	EACH	5	2,987.00	14,935.00
TOTAL BID AMOUNT					166,635.00

**NOTE: BIDDERS SUBMITTING PRICES FOR "APPROVED EQUALS" MUST INCLUDE CATALOG CUTS AND/OR DRAWINGS WITH THEIR BID. SEE SPECIAL PROVISIONS.**

CONTRACTOR'S CERTIFICATION

Contractor, Thorne Electric, Inc., hereby certifies that it  
(Name of Contractor)

is not barred from bidding on the contract for:

**CBD Phase 4 Streetlight Purchase, Project #20-00**

as a result of a violation of either Section 33E-3 or 33E-4 of Article 33E of Chapter 38 of the Illinois Revised Statutes.

Contractor further certifies that it is not delinquent in the payment of any tax administered by the Illinois Department of Revenue, or that the Contractor is contesting its liability for the tax delinquency or the amount of a tax delinquency in accordance with the procedures established by the appropriate Revenue Act. Contractor further certifies that if it owes any tax payment(s) to the Department of Revenue, Contractor has entered into an agreement with the Department of Revenue for the payment of all such taxes that are due, and Contractor is in compliance with the agreement.

By: [Signature]  
Contractor's Authorized Agent Paul H. Thorne

FEDERAL TAXPAYER IDENTIFICATION NUMBER: 36-3168413

or: \_\_\_\_\_  
(Name) (Social Security Number)

Subscribed and sworn to before me this

12th day of December, 2000

[Signature]  
Notary Public

Project #20-00  
cert.DOC



# VILLAGE OF DOWNERS GROVE

PUBLIC WORKS DEPARTMENT

ENGINEERING DIVISION

5101 WALNUT AVENUE

DOWNERS GROVE, ILLINOIS 60515-4074

## Affidavit of Availability

For the Letting of #20-00

### CBD PHASE 4 STREETLIGHT PURCHASE

Instructions: Complete this form by either typing or using black ink. "Authorization to Bid" will not be issued unless both sides of this form are completed in detail. Use additional forms as needed to list all work.

#### Part I. Work Under Contract

List below all work you have under contract as either a prime contractor or a subcontractor, including all pending low bids not yet awarded or rejected. In a joint venture, list only that portion of the work which is the responsibility of your company. The uncompleted dollar value is to be based upon the most recent engineer's or owners estimate. If no work is contracted, show NONE.

	1	2	3	4	Awards Pending	
County and Section Number	DuPage 95 0009500PV	DuPage	Kane 00- 0025200SP	DuPage		
Contract With	Herlihy	Village of Lombard	Kane Co.	Village of Lombard		
Estimated Completion Date	June 01	Jan. 01	March 01	March 01		
Total Contract Price	721,013.00	172,372.00	49,775.00	162,275.00		Accumulated Totals
Uncompleted Dollar Value if Prime Contractor	-----	39,833.00	-----	112,178.00		See Next
Uncompleted Dollar Value if Subcontractor	402,988.00	-----	49,775.00	-----		Page
Total Value of All Work						

#### Part II. Awards Pending and Uncompleted Work to be done with your own forces.

List below the uncompleted dollar value of work for each contract and awards pending to be completed with your own forces. All work subcontracted to others will be listed on the reverse of this form. In a joint venture, list only that portion of the work to be done by your company. If no work is contracted, show NONE.

						Accumulated Totals
Earthwork						
Portland Cement Concrete Paving						
Bituminous Plant Mix						
Bituminous Aggregate Mixture						
Miscellaneous Bituminous Paving						
Clean & Seal Cracks/Joints						
Aggregate Bases & Surfaces						
Highway, R.R. and Waterway Structures						
Drainage						
Electrical	402,988	39,833	49,775	112,178		CON'T
Cover and Seal Coats						
Miscellaneous Concrete Construction						
Landscaping						
Fencing						
Guardrail						
Painting						
Signing						
Fabrication						
Building Construction						
Other Construction (List)						
Totals	402,988	39,833	49,775	112,178		CON'T

Disclosure of this information is **REQUIRED** to accomplish the statutory purpose as outlined under Section 5 of "The Illinois Purchasing Act." Failure to comply will result in the issuance of an "Authorization To Bid." This form has been approved by the State Forms Management Center.

**Part II. Work Subcontracted to Others.**

List below the work, according to each contract on the reverse, which you have subcontracted to others. **DO NOT** include work to be performed by another prime contractor in a joint venture. If no work is subcontracted to others, show **NONE**.

	1	2	3	4	Awards Pending
Subcontractor	NONE	NONE	NONE	NONE	
Type of Work					
Subcontract Price					
Amount Uncompleted					
Subcontractor					
Type of Work					
Subcontract Price					
Amount Uncompleted					
Subcontractor					
Type of Work					
Subcontract Price					
Amount Uncompleted					
Subcontractor					
Type of Work					
Subcontract Price					
Amount Uncompleted					
Subcontractor					
Type of Work					
Subcontract Price					
Amount Uncompleted					
Total Uncompleted					

I, being duly sworn, do hereby declare that this affidavit is a true and correct statement relating to ALL uncompleted contracts of the undersigned for Federal, State, County, City and private work, including ALL subcontract work, ALL pending low bids not yet awarded or rejected and ALL estimated completion dates.

Subscribed and sworn to before me

this \_\_\_\_\_ day of \_\_\_\_\_

Type or Print Name \_\_\_\_\_  
Officer or Director Title

Signed \_\_\_\_\_

Notary Public

My commission expires \_\_\_\_\_

(Notary Seal)

Company \_\_\_\_\_

Address \_\_\_\_\_

# VILLAGE OF DOWNERS GROVE

PUBLIC WORKS DEPARTMENT  
 ENGINEERING DIVISION  
 5101 WALNUT AVENUE  
 DOWNERS GROVE, ILLINOIS 60515-4074

## Affidavit of Availability For the Letting of #20-00

### CBD PHASE 4 STREETLIGHT PURCHASE

Instructions: Complete this form by either typing or using black ink. "Authorization to Bid" will not be issued unless both sides of this form are completed in detail. Use additional forms as needed to list all work.

#### Part I. Work Under Contract

List below all work you have under contract as either a primecontractor or a subcontractor, including all pending low bids not yet awarded or rejected. In a joint venture, list only that portion of the work which is the responsibility of your company. The uncompleted dollar value is to be based upon the most recent engineer's or owners estimate. If no work is contracted, show NONE.

	1	2	3	4	Awards Pending	
County and Section Number	Kane	DuPage 00 0026701TL				
Contract With	Batavia	DuPage DOT				
Estimated Completion Date	Dec. 00	March 01				
Total Contract Price	69,973.00	64,711.00				Accumulated Totals
Uncompleted Dollar Value if Prime Contractor	69,973.00	64,711.00				286,695.00
Uncompleted Dollar Value if Subcontractor	-----	-----				452,763.00
Total Value of All Work						739,458.00

#### Part II. Awards Pending and Uncompleted Work to be done with your own forces.

List below the uncompleted dollar value of work for each contract and awards pending to be completed with your own forces. All work subcontracted to others will be listed on the reverse of this form. In a joint venture, list only that portion of the work to be done by your company. If no work is contracted, show NONE.

					Accumulated Totals
Earthwork					
Portland Cement Concrete Paving					
Bituminous Plant Mix					
Bituminous Aggregate Mixture					
Miscellaneous Bituminous Paving					
Clean & Seal Cracks/Joints					
Aggregate Bases & Surfaces					
Highway, R.R. and Waterway Structures					
Drainage					
Electrical	69,973	64,711			739,458.00
Cover and Seal Coats					
Miscellaneous Concrete Construction					
Landscaping					
Fencing					
Guardrail					
Painting					
Signing					
Fabrication					
Building Construction					
Other Construction (List)					
Totals	69,973	64,711			739,458.00

Disclosure of this information is **REQUIRED** to accomplish the statutory purpose as outlined under Section 5 of "The Illinois Purchasing Act." Failure to comply will result in issuance of an "Authorization To Bid." This form has been approved by the State Forms Management Center.

**Part II. Work Subcontracted to Others.**

List below the work, according to each contract on the reverse, which you have subcontracted to others. **DO NOT** include work to be performed by another prime contractor in a joint venture. If no work is subcontracted to others, show **NONE**.

	1	2	3	4	Awards Pending
Subcontractor	NONE	NONE			
Type of Work					
Subcontract Price					
Amount Uncompleted					
Subcontractor					
Type of Work					
Subcontract Price					
Amount Uncompleted					
Subcontractor					
Type of Work					
Subcontract Price					
Amount Uncompleted					
Subcontractor					
Type of Work					
Subcontract Price					
Amount Uncompleted					
Subcontractor					
Type of Work					
Subcontract Price					
Amount Uncompleted					
Subcontractor					
Type of Work					
Subcontract Price					
Amount Uncompleted					
Total Uncompleted					

I, being duly sworn, do hereby declare that this affidavit is a true and correct statement relating to ALL uncompleted contracts of the undersigned for Federal, State, County, City and private work, including ALL subcontract work, ALL pending low bids not yet awarded or rejected and ALL estimated completion dates.

Subscribed and sworn to before me  
 this 11th day of December, 2000

Shelly Thorne  
 Notary Public

My commission expires 6-28-01

(Notary Seal)

Type or Print Name Paul H. Thorne Manager  
Officer or Director Title

Signed [Signature]

Company Thorne Electric, Inc.

Address P.O. Box 321 Wheaton, IL 60189

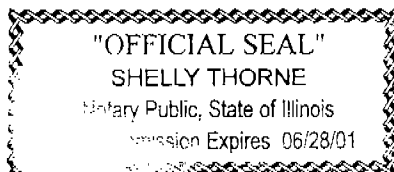

VILLAGE OF DOWNERS GROVE

C O N T R A C T

1. THIS AGREEMENT, made and concluded this \_\_\_ day of \_\_\_\_\_, 20\_\_\_, between the Village of Downers Grove acting by and through its Council, known as the party of the first part, and \_\_\_\_\_ his/their executors, administrators, successors or assigns, known as the party of the second part.

2. WITNESSETH: That for and in consideration of the payments and agreements mentioned in the Proposal hereto attached, to be made and performed by the party of the first part, and according to the terms expressed in the Bond referring to these presents, the party of the second part agrees with said party of the first part at his/their own proper cost and expense to do all the work, furnish all materials and all labor necessary to complete the work in accordance with the Plans, General Conditions, Supplementary General Conditions, and Specifications hereinafter described, and in full accordance with all the terms of this agreement and the requirements of the Owner under it.

3. And it is also understood and agreed that the Notice to Contractors, General Conditions, Supplementary General Conditions, Specifications, Proposal and Contract Bond hereto attached, for the **CBD Phase 4 Streetlight Purchase, PROJECT 20-00**, and prepared by the Village of Downers Grove are all essential documents of this part hereof.

4. IN WITNESS WHEREOF, the said parties have executed these presents on the date above mentioned.

ATTEST: THE VILLAGE OF DOWNERS GROVE

\_\_\_\_\_  
Village Clerk

\_\_\_\_\_  
Mayor

(Seal)

If a Corporation:

ATTEST:

Corporate Name \_\_\_\_\_

\_\_\_\_\_  
Secretary

By \_\_\_\_\_  
President  
Party of the Second Part

If a Co-Partnership: \_\_\_\_\_ (Seal)

(Corporate Seal)

\_\_\_\_\_ (Seal)

\_\_\_\_\_ (Seal)

Partners doing business under the firm name of

\_\_\_\_\_  
Party of the Second Part

If an Individual:

\_\_\_\_\_ (Seal)  
Party of the Second Part